

ERIC COREY FREED

Principal, organicarchitect

Eric Corey Freed, LEED AP, Hon. FIGP, is Principal of organicARCHITECT, an architecture and consulting firm in California, with nearly 20 years of experience in green building.

Eric co-developed the Sustainable Design programs at the Academy of Art University and University of California Berkeley Extension. He is on the boards of Architects, Designers & Planners for Social Responsibility (ADPSR), Green Home Guide and West Coast Green, as well as the advisory boards of nearly a dozen other organizations.

He was the founding Chair of Architecture for The San Francisco Design Museum and one of the founders of ecoTECTURE: The Online Journal of Ecological Design. He is a regular contributor for Sustainable Industries Journal, Luxe, Natural Home, Metropolitan Home and dozens of other publications. Eric lectures around the country at 40+ conferences a year, and his work has been featured in Dwell, Metropolis, Town & Country, Natural Home and Newsweek. He has been seen on television on Fox News, HGTV, The Sundance Channel and PBS.

Eric is the author of four books, including "Green Building & Remodeling for Dummies", a best seller with over 100,000 copies in print. His latest books, "Sustainable School Architecture" and "Green\$ense for your Home" were just released in 2010.

Eric is considered a leader in the field; named by San Francisco Magazine "Best Green Architect" in 2005 and "Best Visionary" in 2007; and "Green Visionary" by 7x7 Magazine in 2008.

CONNECT:

facebook

Linked in

twitter

415.474.7777

info@organicarchitect.com

Slides in this presentation may be used with proper credit for non-commercial use only.

Other uses require written permission.

Sources are listed on each slide where relevant. Image sources are listed when available.





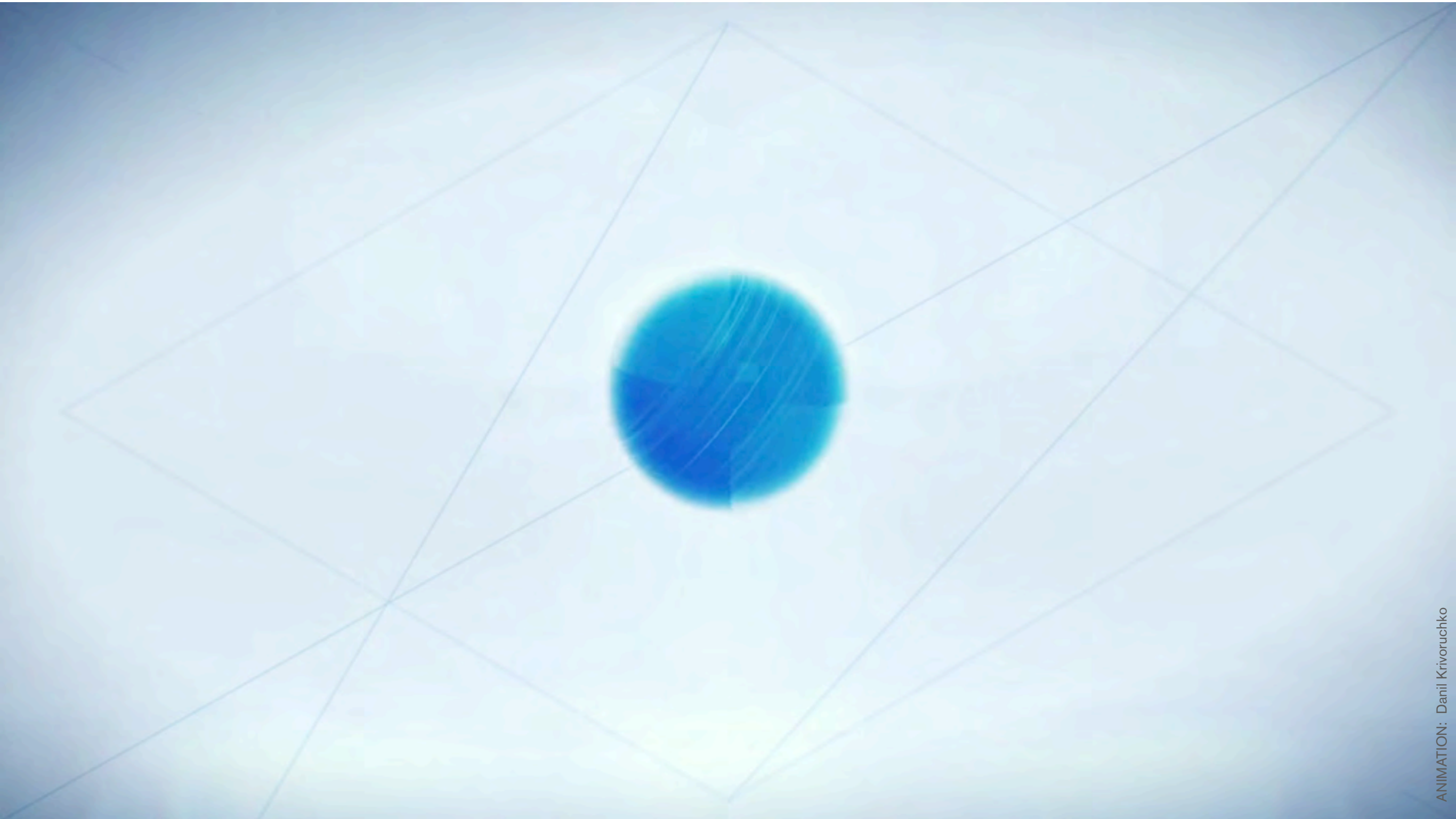

ericcoreyfreed

CONNECT:



DOWNLOAD THIS PRESENTATION:

dodosapiens.com



ericcoreyfreed

FOUNDING PRINCIPAL
organicarchitect

Honorary Fellow, Institute of Green Professionals
LEED Accredited Professional

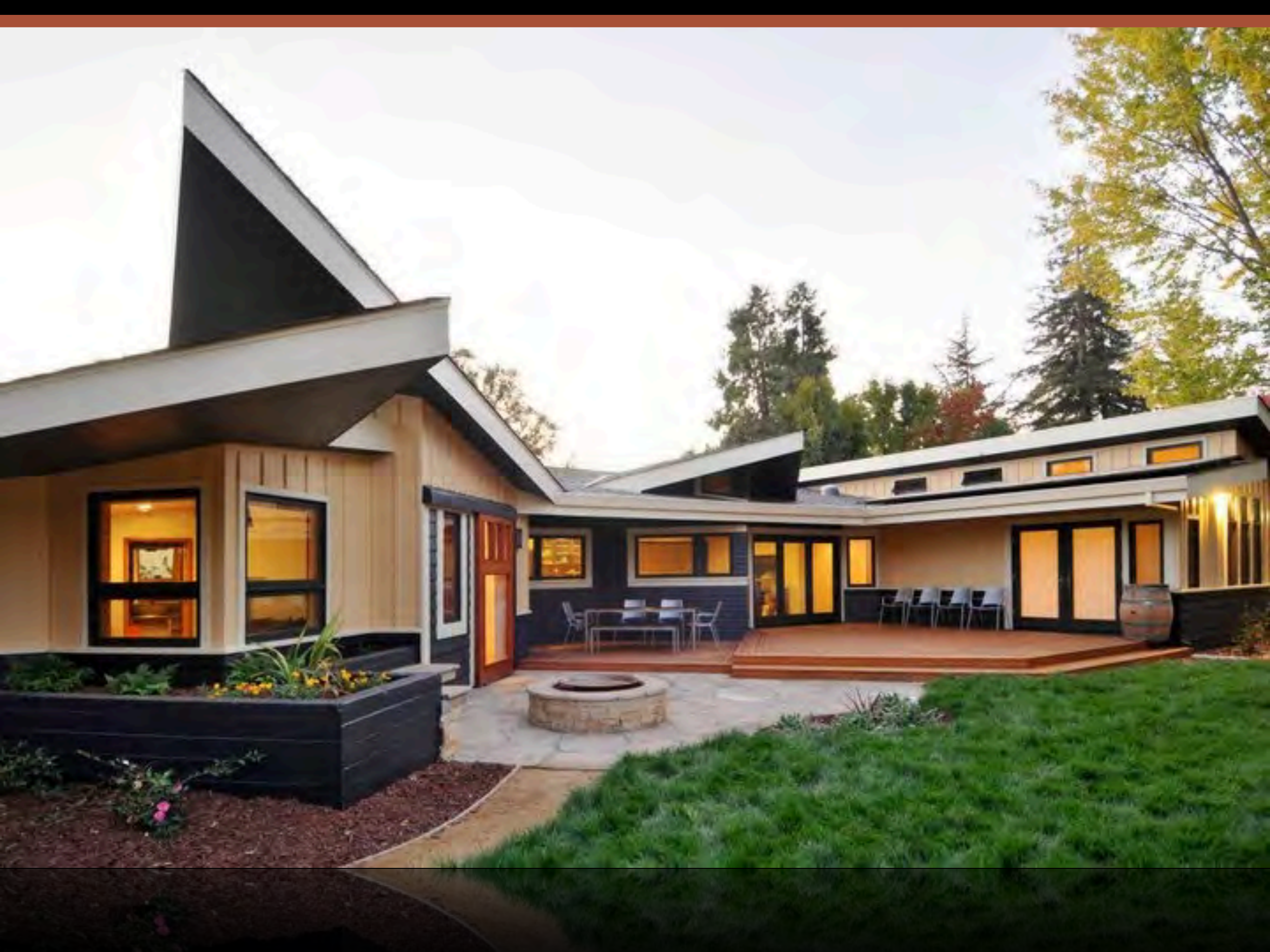



organic **architect**™

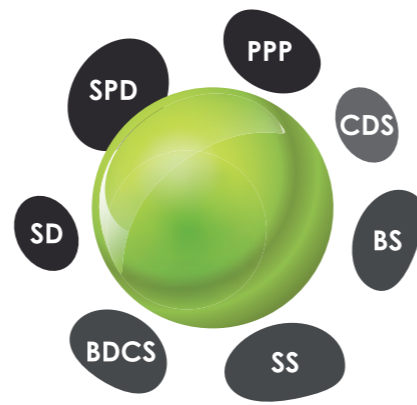

ARCHITECT
e x a m P R E P



Best Green Architect
 2005



THE WORLD CLASS
 IN ANDY GARCIA'S
 WYKEZ HER FILM DEBUT
 THE ACCLAIMED BALLERINA
GOES LIGHTLY!
 LORENA FELJÓ



**BOSTON
ARCHITECTURAL
COLLEGE**



UC Berkeley Extension



**ACADEMY *of* ART
UNIVERSITY**

UC RIVERSIDE UNIVERSITY OF CALIFORNIA

CityUniversity
of Seattle



SEEING GREEN

THE ROOF HOLDS SECRETS AND UNTAPPED POTENTIAL WHEN IT COMES TO GREEN HOME DESIGN. TRADITIONALLY A PLACE FOR CHRISTMAS LIGHTS AND LOST FRISBEES, THE ROOF OF MOST HOMES COULD POSSIBLY PRODUCE ALL OF A HOME'S ENERGY NEEDS. THIS FEAT OF MAGIC COMES FROM SOLAR PANELS, AN OLD TECHNOLOGY.

SOLAR PANELS (AKA: PHOTOVOLTAIC PANELS, OR PV PANELS) ARE THE LATEST STATUS SYMBOL, ALONGSIDE HYBRID CARS, FOR THOSE WHO LIKE TO SHOW OFF THEIR GREEN APTITUDE. AND WITH GREEN CONSCIOUSNESS ON THE RISE, BARE ROOFS MIGHT GO THE WAY OF THE DINOSAUR. RECENTLY OVERHEARD AT A CONFERENCE: "EVERYONE WHO IS ANYONE PUTS SOLAR ON THEIR ROOFS."

LIGHT YEARS

The Earth receives more energy from the sun in just one hour than the world uses in an entire year.



SOLAR INSPIRATION

WRITTEN BY ERIC COREY FREED



CURRENT THINKING

The principle behind a solar panel is simpler than you might expect: French scientist Edmond Becquerel in 1839 first discovered the photovoltaic effect—which makes solar power possible. When sunlight strikes the panel's thin wafers of silicon, the electrons get "jostled" and start moving, and this produces electrical current.

Companies are seeking ways to produce more efficient solar panels, yet all panels essentially use the same type of solar cells used since Bell Labs produced the first silicon solar panels in 1954. Consider this: It is a 53-year-old product based on a 168-year-old scientific discovery. With that kind of history, solar power is hardly a trend or a risky new alternative.



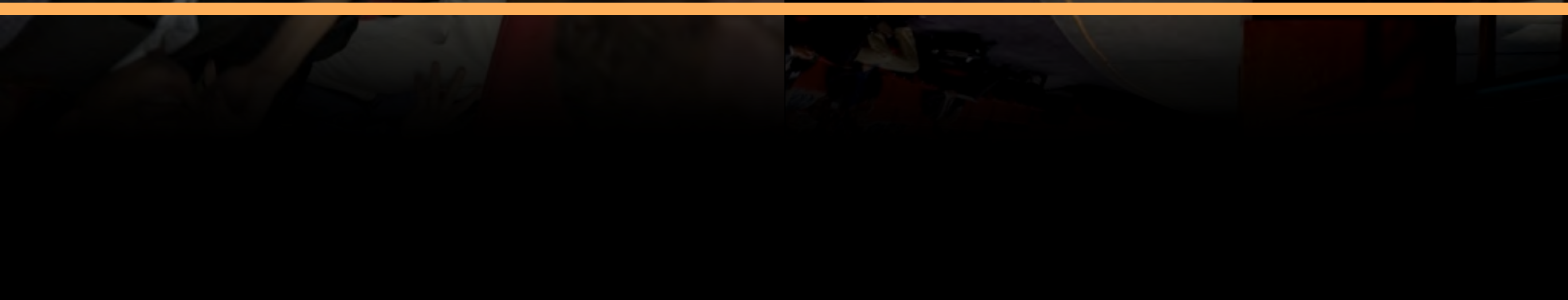



SOURCE: University of Detroit Mercy



SOURCE: Center for Responsive Politics, OpenSecrets.org

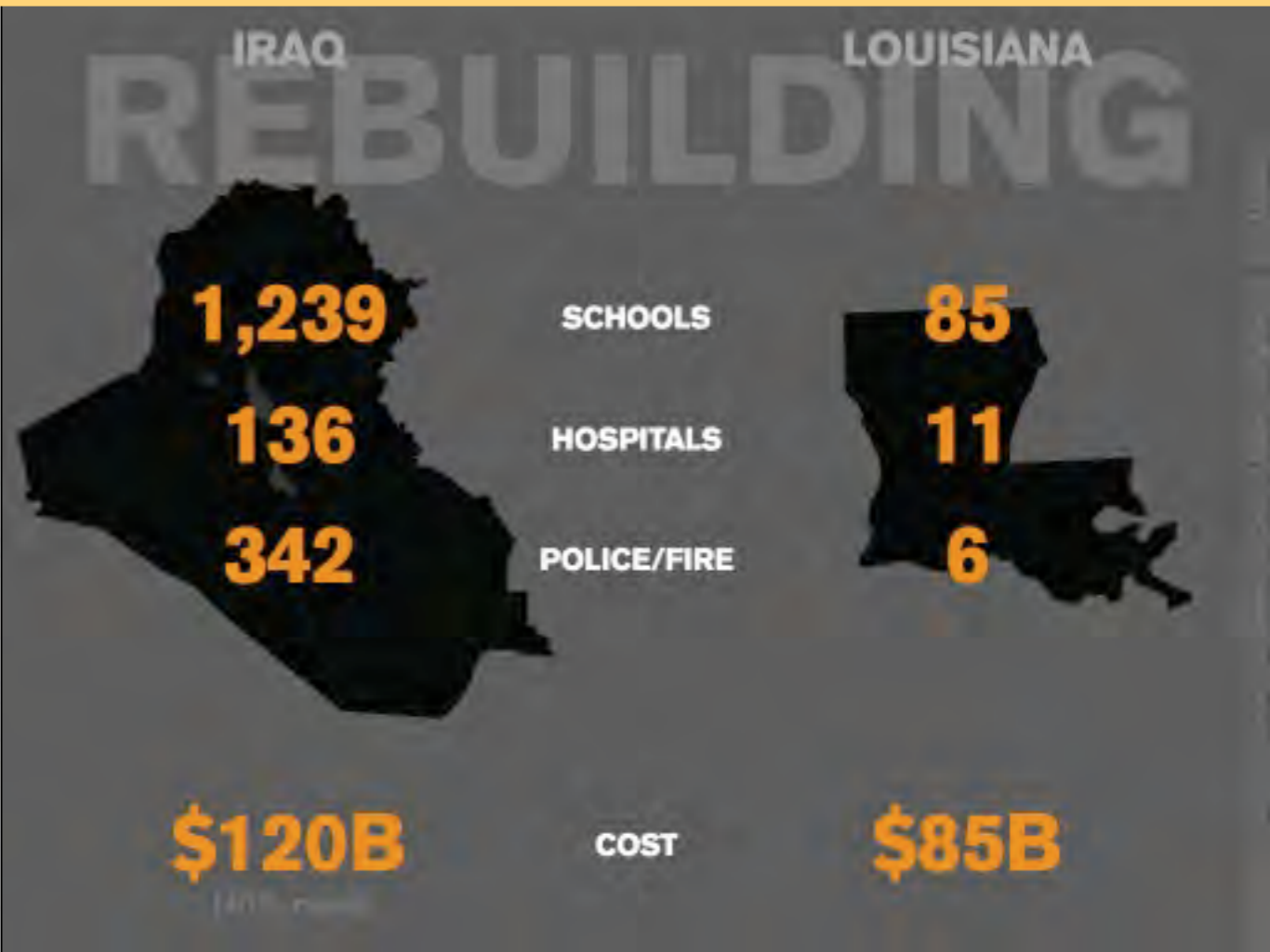

LIVE
SAN FRANCISCO

MARKET ALERT
9572.16
140.12

FOX BUSINESS

Eric Corey Freed
ORGANIC ARCHITECT FOUNDER

INTERNET TECHNOLOGY TOP STORIES

AKAMAI (AKAM) 18.78 0.90

S&P 1038.30 18.80 NASDAQ 2073.20 49.22

11:46 a ET

Eric Corey Freed
Author/Architect

LIVE
7:54 a PT

FOX BUSINESS

Eric Corey Freed
URBAN RE:VISION EXECUTIVE DIRECTOR

FOX FIFTY TOP STORIES WEATHER

UPS (UPS) 57.19 0.03

DOW 10293.90 38.54 S&P 1088.75 6.15 NASDAQ 2139.61 17.21

CONSERVATION
MAKE YOUR LIFE EASIER
WORLD A BETTER

American Standard
Style That Works

Eric-Corey Freed
Author
Green Building
for Dummies

green//build//pro

Eric Corey Freed
FOUNDER, ORGANIC ARCHITECT

smartplan

Eric Corey Freed
Executive Director
organicARCHITECTURE

LIVE
7:54 a PT

FOX BUSINESS

GREENER TAXES

FOX FIFTY TOP STORIES WEATHER

CHARLES SCHWAB (SCHW) 18.10 0.21

DOW 10293.30 39.14 S&P 1088.70 6.20 NASDAQ 2139.47 17.35

ERIC COREY FREED

LIVE

FOX BUSINESS

**GREEN BUILDINGS HAVE HIGHER
WORKER PRODUCTIV. IN FACTORIES**

INTERNET TECHNOLOGY TOP STORIES

YAHOO! INC (YHOO) 17.34 0.47

11:46 a ET S&P 1038.25 18.85 NASDAQ 2072.96 49.46



NEXT AMERICAN
CITY
americancity.org

**Sustainable
Industries**

**Metropolitan
Home**

LIVING WISELY > LIVING WELL
natural
HOME

dwell

K+BB THE OFFICIAL SPONSOR OF KBIS

**common
ground**

california
HOME+DESIGN

ed+c
environmental design + construction

luxe.
interiors + design®

The New York Times

San Francisco Chronicle
NORTHERN CALIFORNIA'S LARGEST NEWSPAPER

Marin Independent Journal
www.marinij.com

 The Desert Sun
SERVING THE COACHELLA VALLEY SINCE 1921

FINANCIAL
TIMES

SAN FRANCISCO

Forbes[®]
Entrepreneur[®]
MAGAZINE

FASTCOMPANY

THE SAN FRANCISCO BAY
GUARDIAN

Money
FOR YOU, YOUR FAMILY, YOUR FUTURE

DON'T APOLOGIZE

PHOTO: Mark Singer Photography – DESIGN: organicARCHITECT



HIPPIES

USE

BACKDOOR

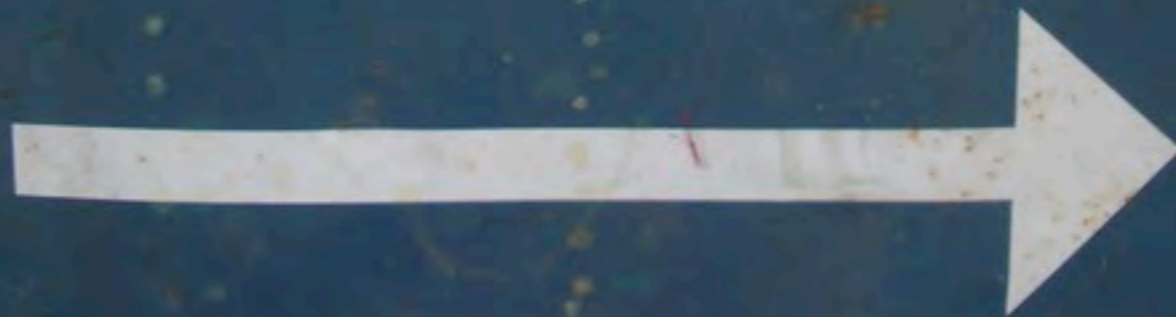

NO EXCEPTIONS

the **5** stages of grief

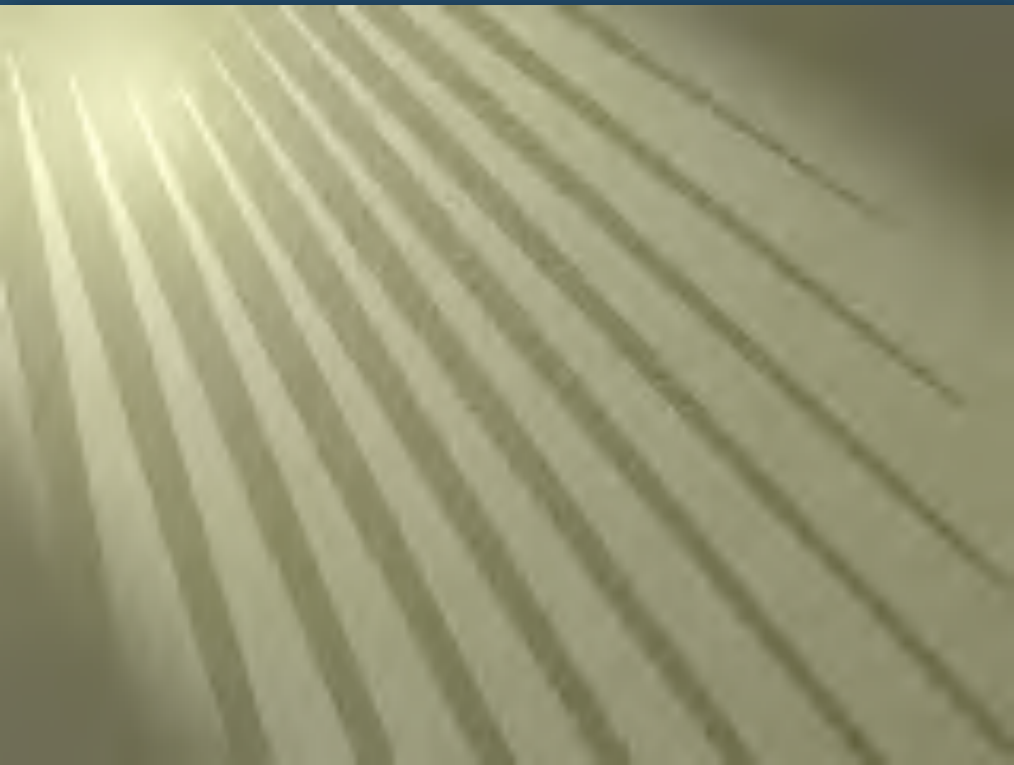

1

Denial.

“This can't be happening...”

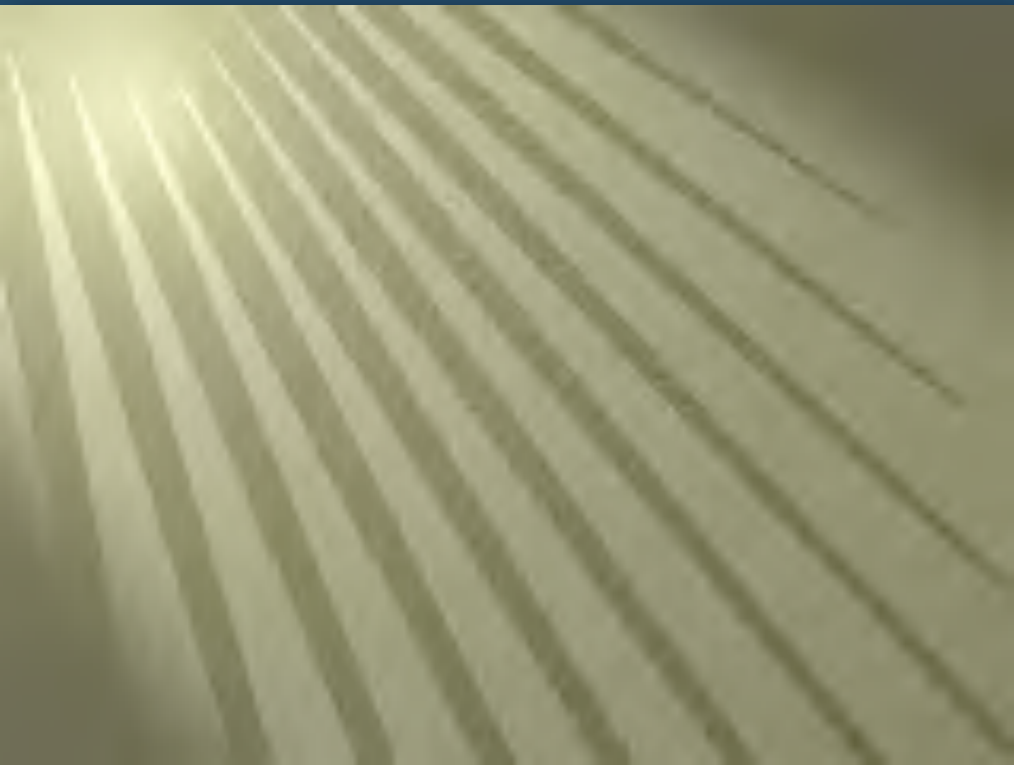

2 Anger.

“It’s not fair!”

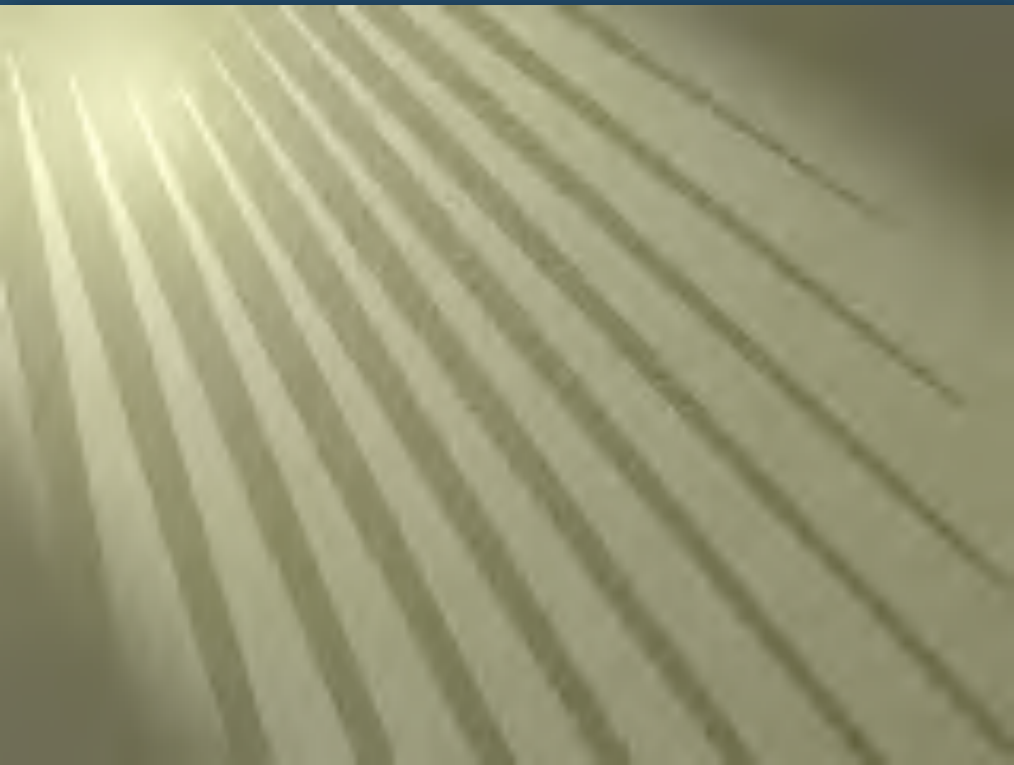

3 Bargaining.

“Can’t this wait a little more?”

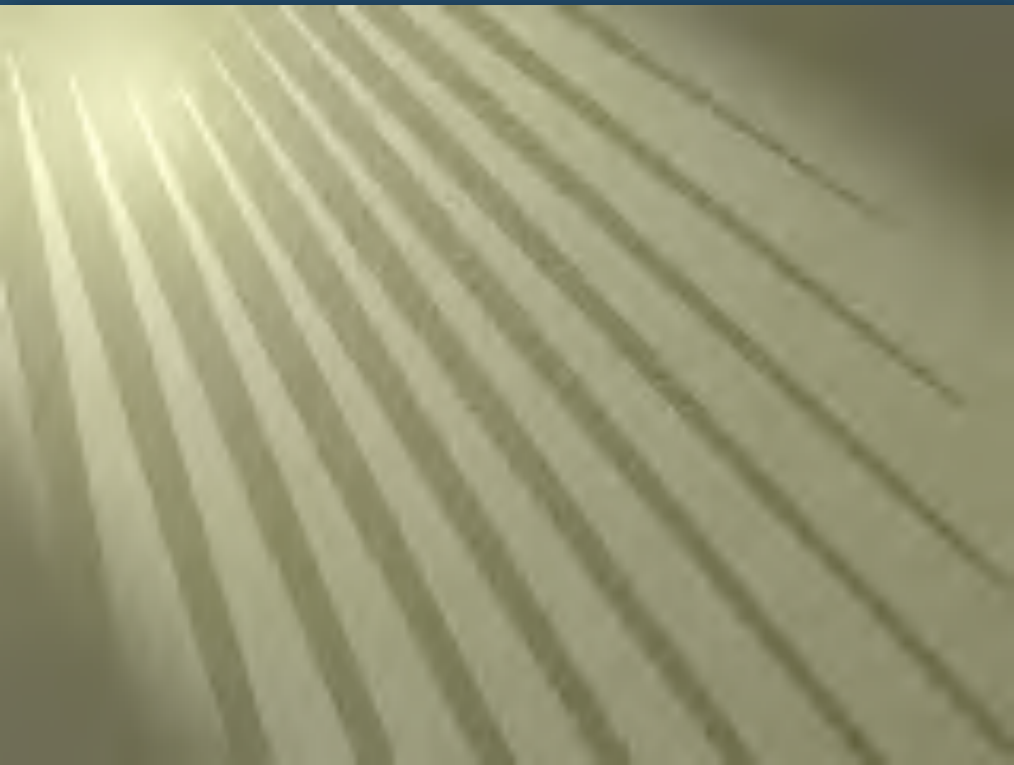

4 Depression.

“What’s the point?!”

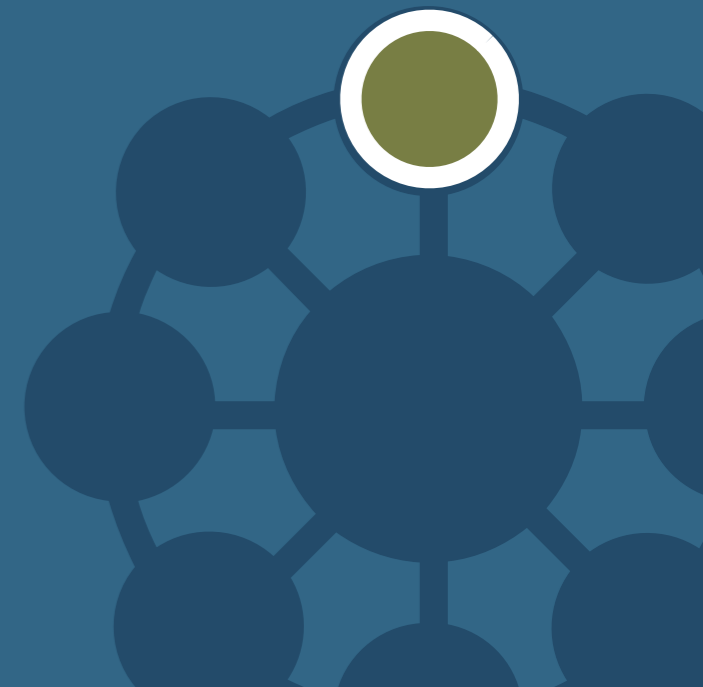
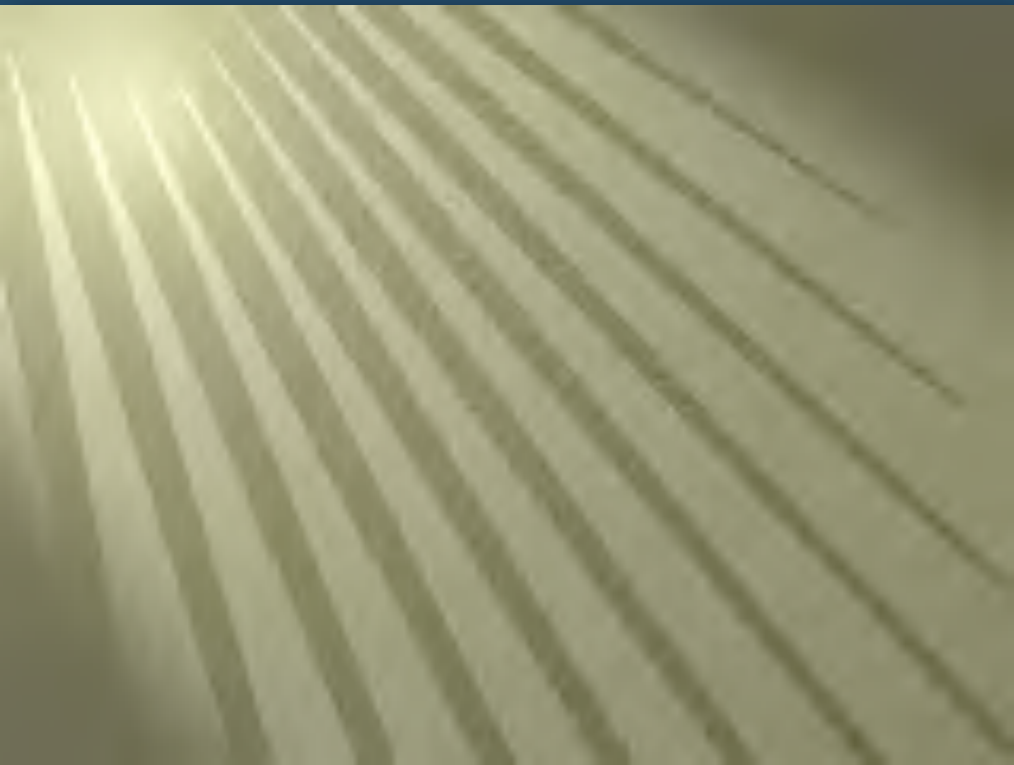

5 Acceptance.

“Everything will be OK!”

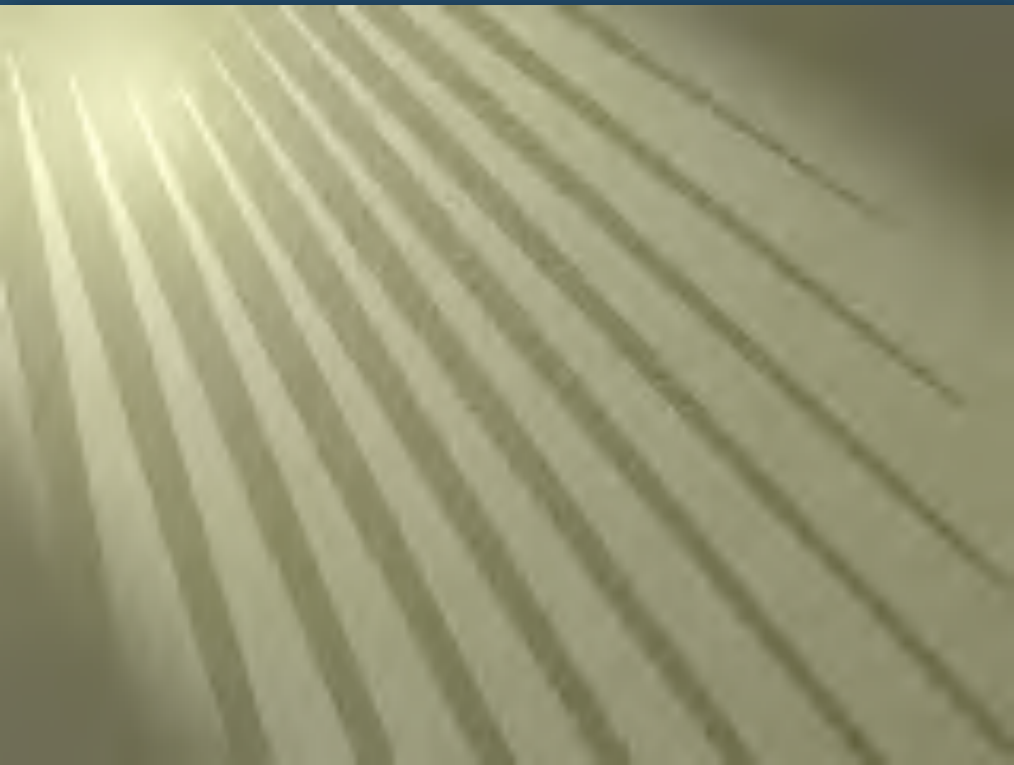



greenwash |'grēn,wä sh; –,wô sh
noun

disinformation disseminated by an organization so as to present an environmentally responsible public image.

“That oil company is, like, totally greenwashing.”





Every drop is green.



Every drop is green.





 Our new Eco-Shape™ bottle is getting quite a reaction.

Nature appreciates the little things you do for it. Like recycling, carpooling and choosing the new Ozarka® Eco-Shape bottle with less plastic – 30% less, in fact, than the average half-liter.* Less plastic means less impact on the earth. Because when we all do a little, it can add up to a lot.



When we go green, we go all the way.

DON'T THROW ANYTHING AWAY THERE IS NO AWAY.

IF ONLY WE HAD A MAGIC BIN THAT WE COULD THROW STUFF IN AND MAKE IT DISAPPEAR FOREVER. WHAT WE CAN DO IS FIND CREATIVE WAYS TO RECYCLE. WE USE OUR WASTE CO₂ TO GROW FLOWERS. AND OUR WASTE SULPHUR TO MAKE SUPER-STRONG CONCRETE. REAL ENERGY SOLUTIONS FOR THE REAL WORLD. WWW.SHELL.COM/REALWORLD





Eco-Dismol

100% ORGANIC
UPSET TUMMY RELIEVER

USGBC Approved

**Soothing
Relief for
5 Symptoms**

- Greenwashing
- Bad Karma
- Bad Vibes
- Tofu Attacks
- Negativity



8 FL OZ (236 mL)

Gateway

MOTEL

TO VACANCY

LEED Certified

Hippies Welcome.



4,389,443

u.s. hotel rooms

u.s. hotels consume enough to power over

1,146,500

homes



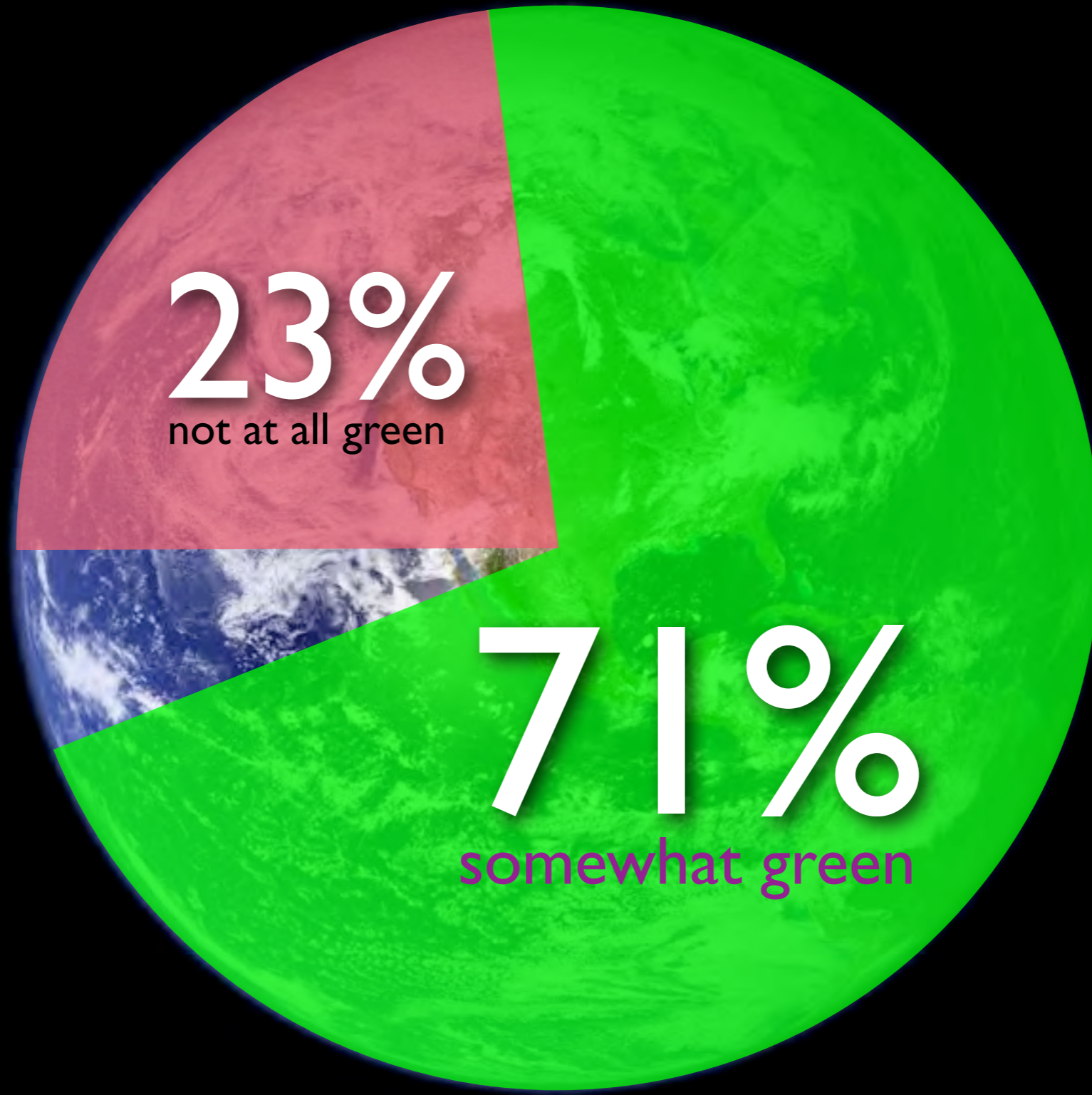

perception of the lodging industry
among business travelers

\$ **3,700,000,000**

spent on energy



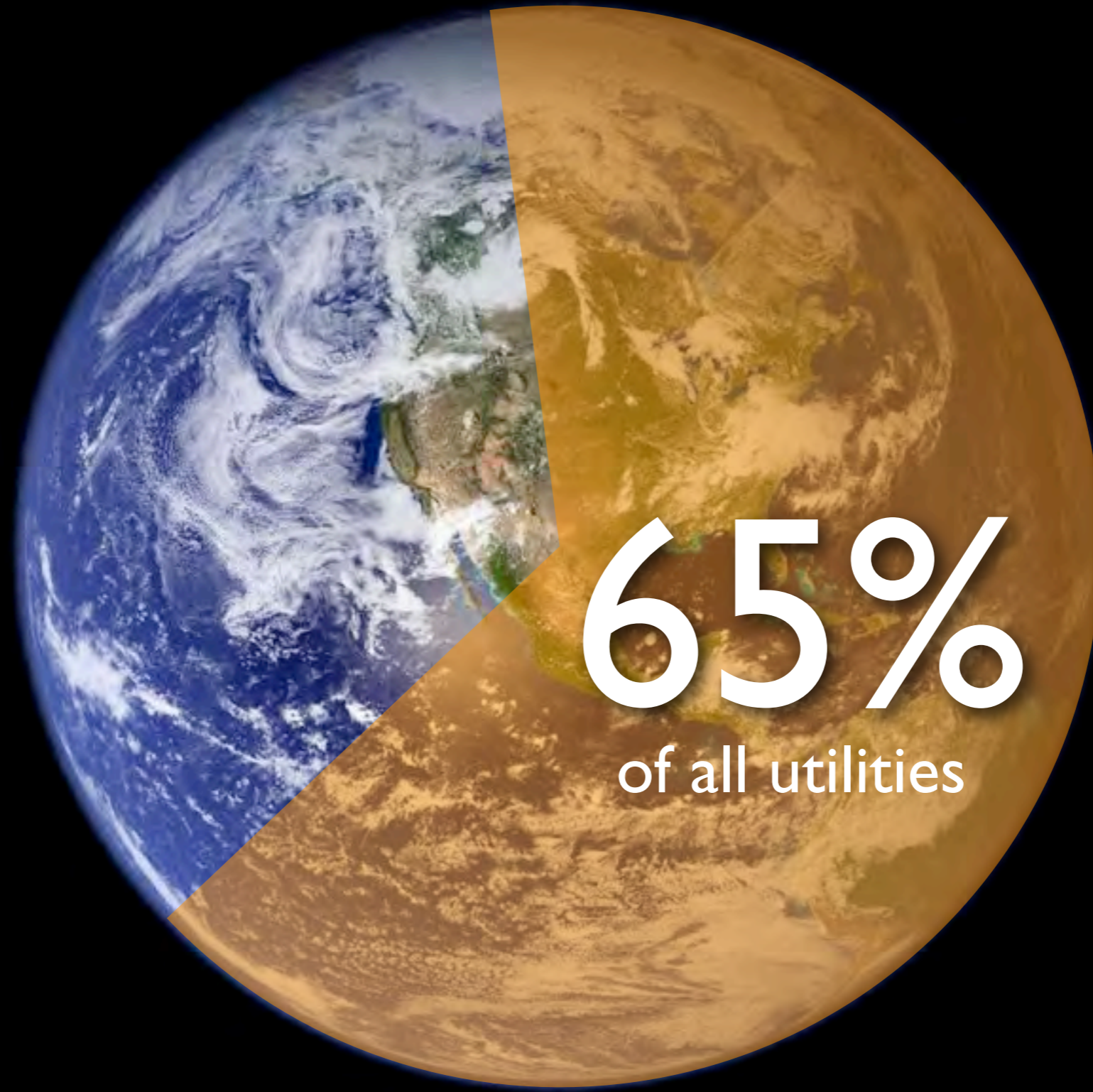

electricity use
% of all utilities

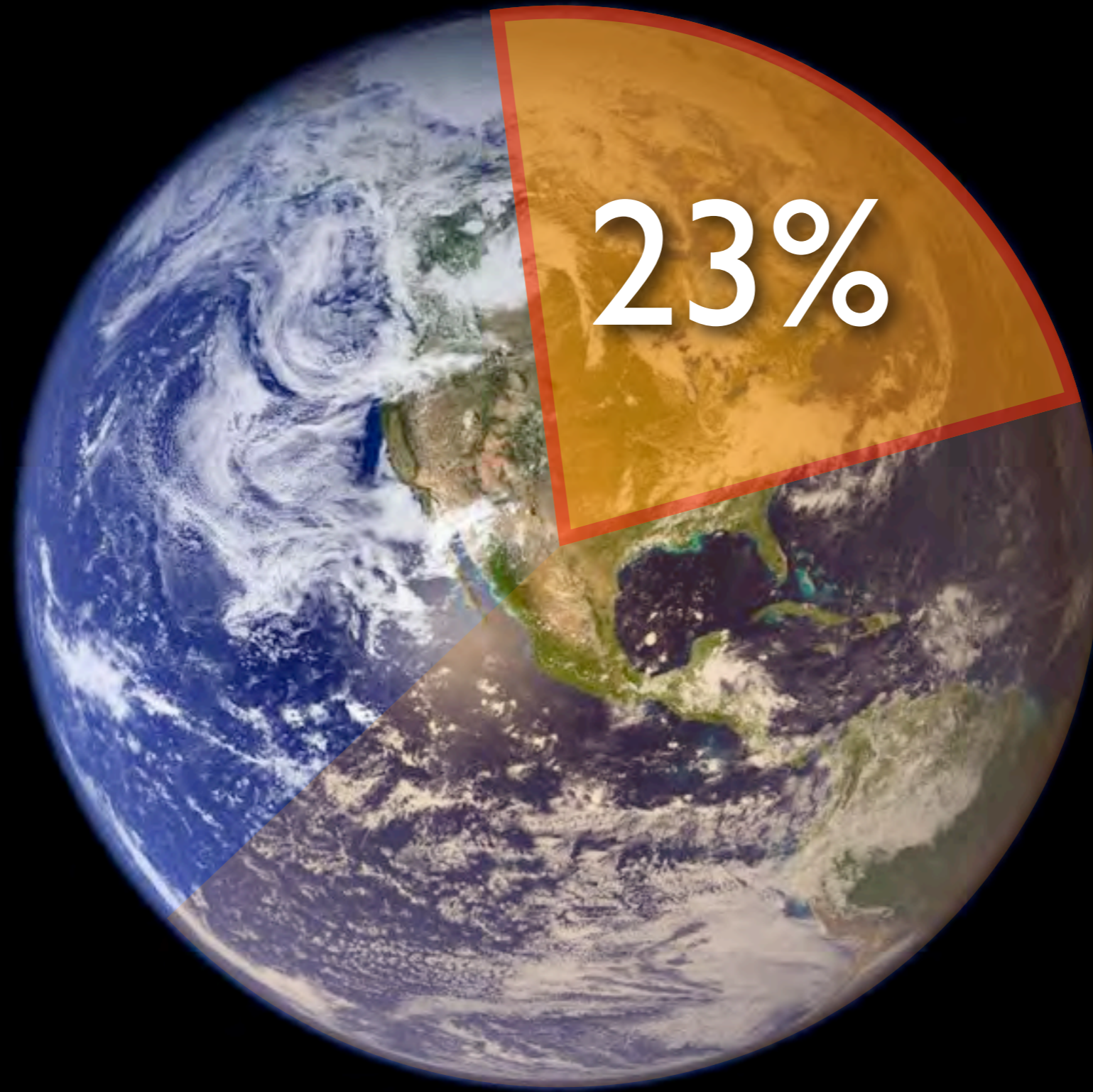

electricity use lighting only
% of all utilities

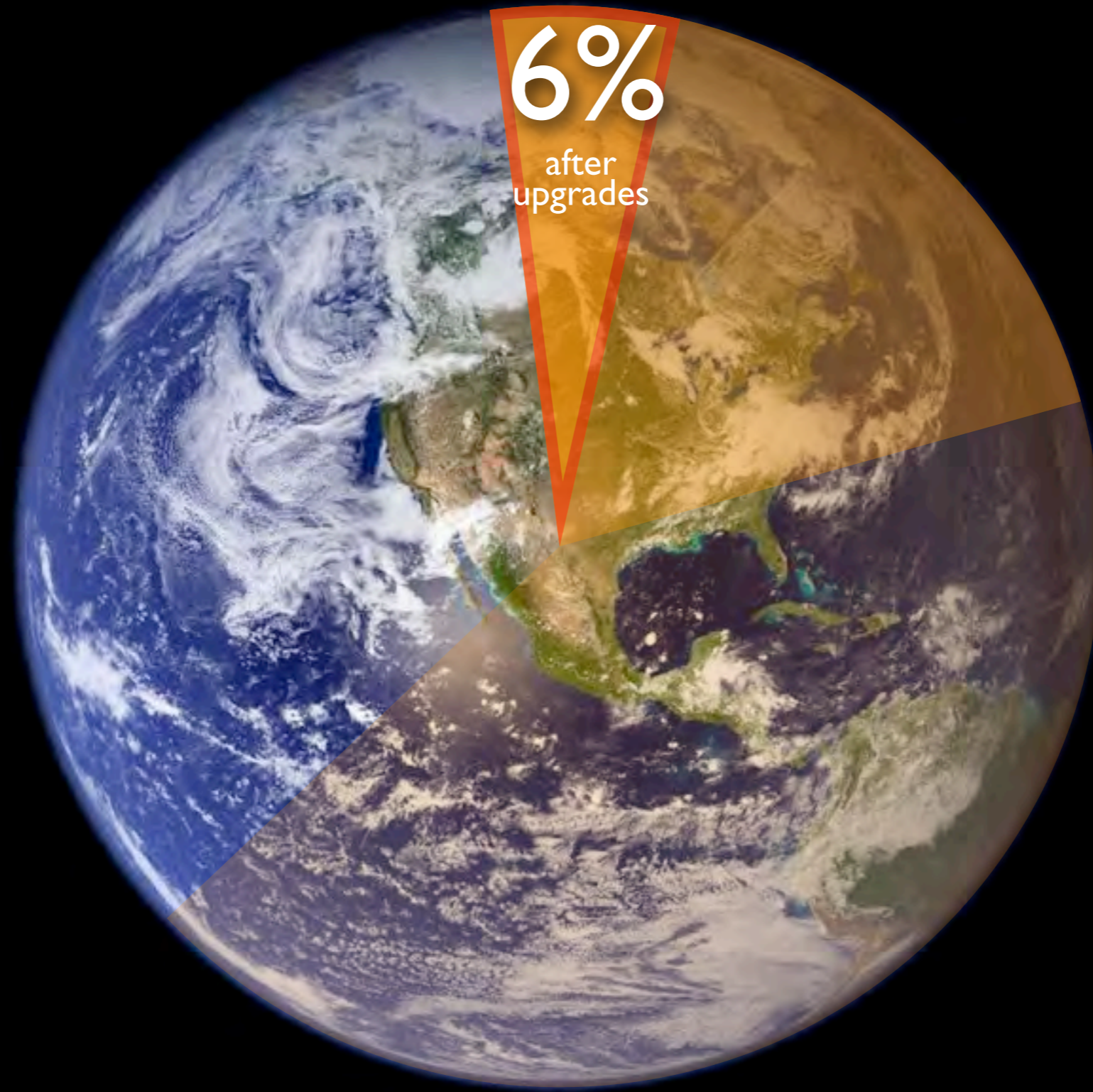

electricity use potential after upgrades
% of all utilities

**10% energy
reduction is
equivalent to
increasing
ADR by \$2.45**



green hotels

\$11
increase

in RevPAR



potential water savings
using ultra low flow fixtures



Hoshi Ryokan Hotel

718

A.D.





VOC PAINT

Unhealthy paints used.
Could be VOC free.

TRAPPED AIR

Windows don't open to
allow fresh air.

OVER LIT

Lights are hard to control
and easy to leave on.

FORMALDEHYDE

Cabinets contain high
levels of formaldehyde.

PESTICIDES

Linens contain chemicals
and harsh detergents.

VAMPIRES

Power is consumed
whether needed or not.

ALLERGENS

Carpets trap dust and
need constant vacuuming.

TOXINS

Cleaners contain harsh
chemicals.

MISSED OPPORTUNITIES

REGAL
Prince of Golden Beers
HISKEY



DRINK
JAX
BEST BEER IN TOWN



BARBEQUE and COLD BEER

FRENCHIES BAR

Frenchies
BEER GARDEN

Hires
R-J
ROOT BEER

NEHI
ROOT BEER

DENTAL
SNUFF

TOP

DRINK
Coca-Cola

WE SERVE
Quality
ICE CREAM
MADE BY
QUALITY ICE CREAM CO.





FAKE

Anachronistic styles don't relate to local community.

WASTED

Fake attics & elements could be leased instead.

SETBACK

Loss of street wall destroys community.

CAR CENTRIC

Puts car before people, misses chance to create real places.

SINGLE USE

No diversity of function misses chance to create community.

STRUCTURE

Over engineered and overbuilt, wastes materials.

STOREFRONT

Front facing stores creates unsightly rear elevations.

CLIMATE

Standardized designs are inappropriate for most climates.

MISSED OPPORTUNITIES: OUTSIDE



LIGHTING

Over lit, poorly planned & inflexible wastes energy.

NO AIR

Windows don't open to allow fresh air.

LAYOUTS

Shelves placed for products, not for people.

UNHEALTHY

Toxic paints, floors and sealants used.

TOO WHITE

Lack of color won't stimulate shoppers.

SIGHT LINES

Over emphasis on products loses chance to create a place.

PRODUCTS

Unhealthy products miss chance to connect to customer.

FORMALDEHYDE

Cabinetry use toxic glue in most common materials.

MISSED OPPORTUNITIES: INSIDE



FINISHES

Recycled, non-toxic, locally sourced, sustainable.

TASK LIGHTS

Only light the work areas to save energy.

CASH WRAP

Recycled paper, soy based inks & optional to use.

CABINETRY

Use formaldehyde free cabinets & FSC or bamboo doors.

DAYLIGHT

Increase sales with natural light.

FLOORING

Hard flooring doesn't trap allergens.

FIXTURES

Reusable, renewable, durable & recyclable.

PRODUCTS

Healthy, local & renewable.

GREEN RETAIL STORE



the state of “green” hotels

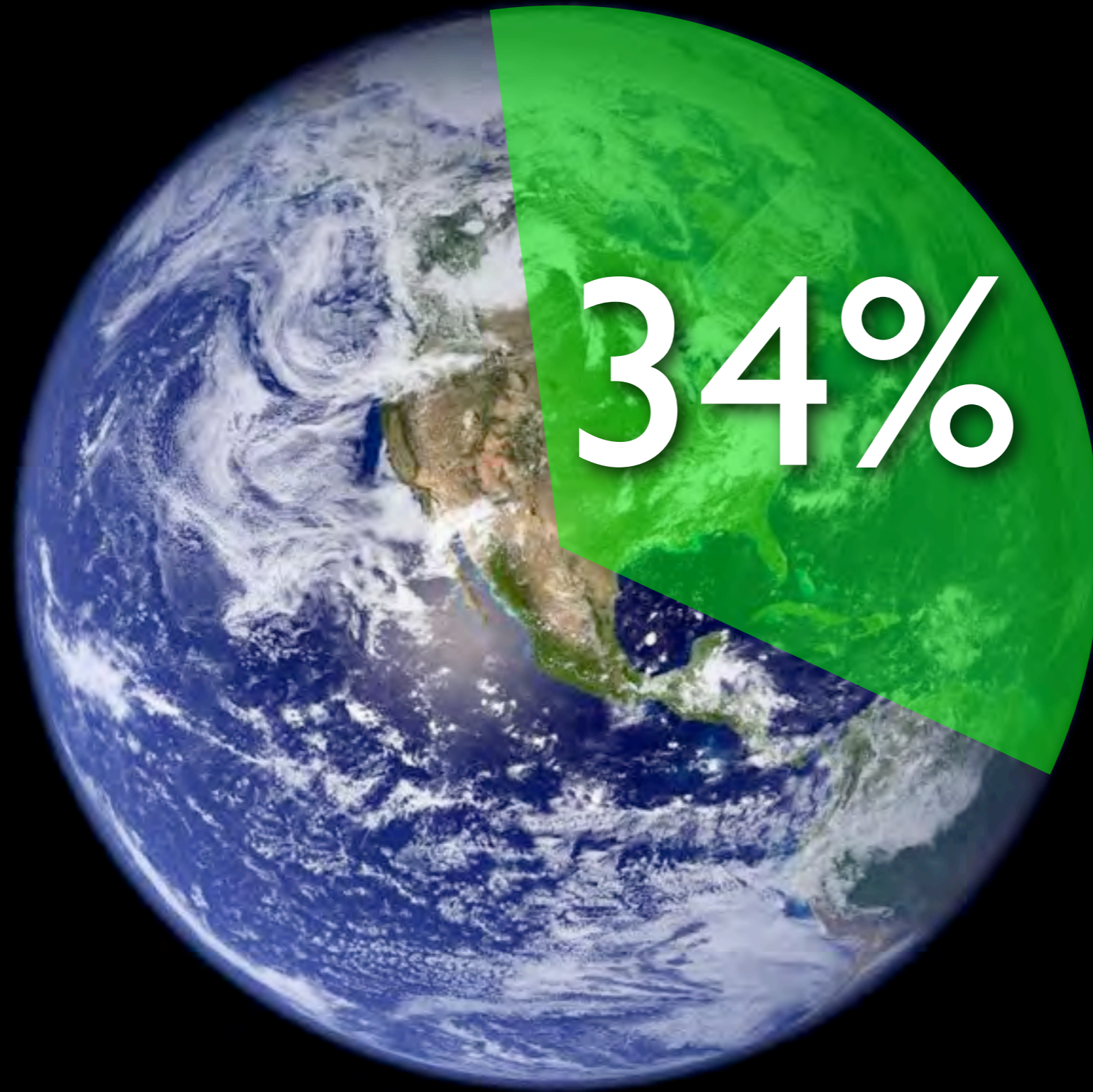

seek out green hotels
among business travelers



SAVE OUR PLANET!

Dear Guest:

Every day tons of detergent and millions of gallons of water are used to wash towels that have been used only once.

PLEASE DECIDE FOR YOURSELF.

A towel on the rack
means
"I'll use it again."

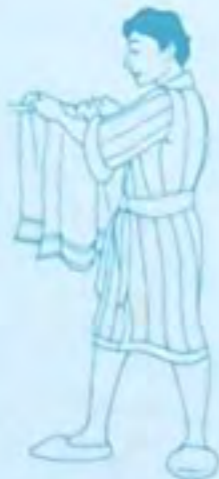

A towel on the floor
or in the tub means
"please exchange."

A Percentage of Profits Is Being Donated to Environmental Groups
© 2004 "Green" Hotels Association
P. O. Box 420212 Houston, TX 77242-0212
www.greenhotels.com, e-mail: green@greenhotels.com
713/789-8889, Fax 713/789-9786



SAVE MOTHER EARTH!

Bed sheets washed daily in thousands of hotels in this world use millions of gallons of water and tons of detergent.

Sheets are customarily changed daily. If you feel that this is unnecessary, please leave this card on your pillow in the morning. Your bed will be made, but your sheets will not be changed that day.

PLEASE DECIDE FOR YOURSELF.



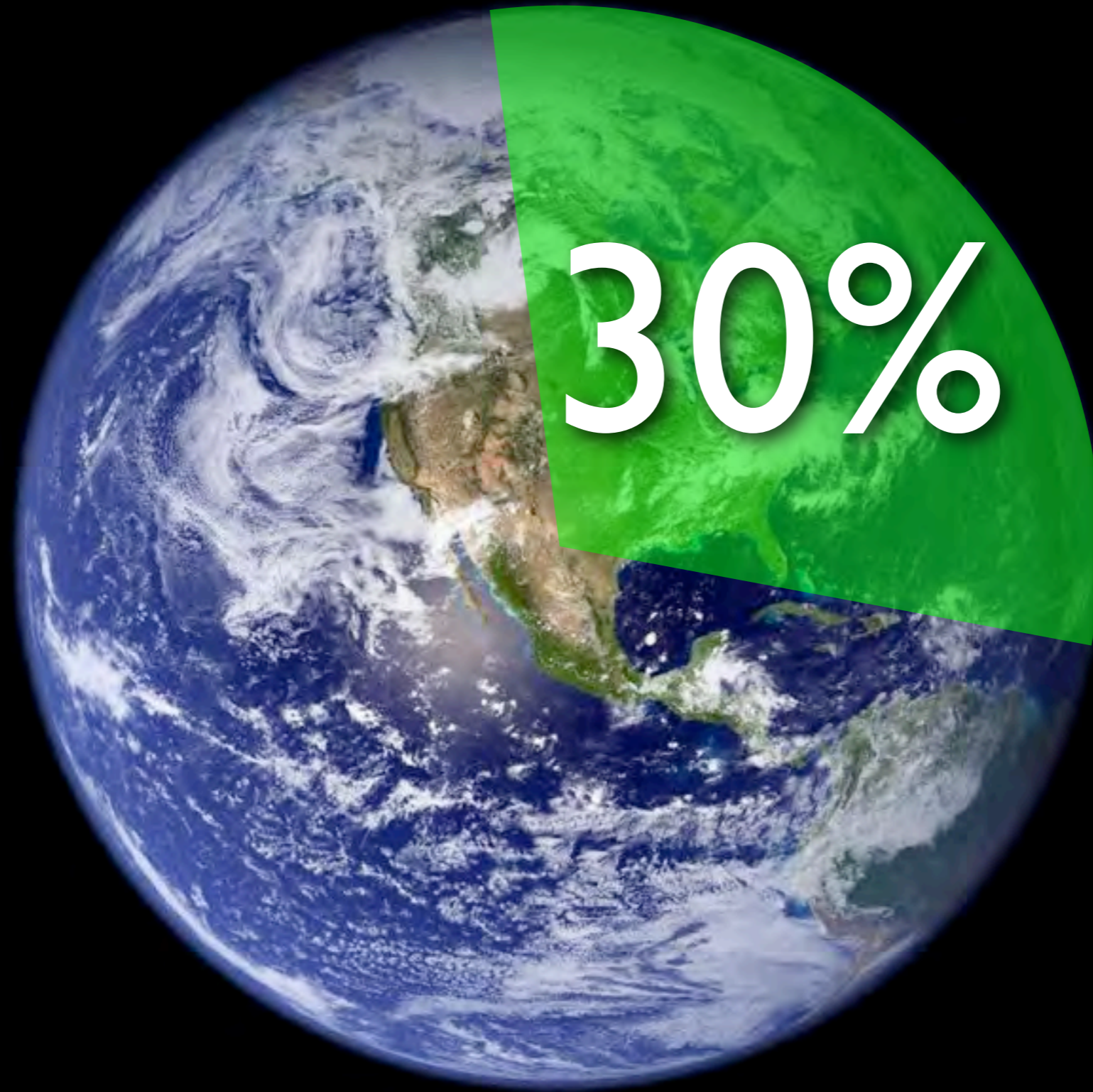

requested linen reuse, but hotel changed anyway
among business travelers



not allowed to be as green as desired
among business travelers



it's getting crowded in here...





GREEN leaders

low hanging fruit



LINEN REUSE

Proper signage and education.

LOW FLOW SHOWERS

Uses 2.5 gallons per minute (instead of 5).

LOW FLUSH TOILETS

Uses 1.6 gallons per flush (instead of 5).

CFL BULBS

Lasts 10 times as long; uses tenth of energy.

DIGITAL THERMOSTATS

Programmable and accurate.

RECYCLING

Lowers your waste bill.

ENERGY STAR EQUIPMT

Pays for itself in less than a year.

NON-TOXIC CLEANERS

Fewer claims from staff.



\$467
increase per square foot savings



Avalon Hotel
Portland, Oregon
Silver - 2008



Gaia Napa Valley
Napa, California
Gold - 2007



Hotel Terra
Teton Village, Wyoming
Silver - 2008



Vancouver Hotel
Vancouver, Washington
Certified - 2006



University of Maryland Inn
Adelphi, Maryland
Certified - 2005



Hyatt Olive 8
Seattle, Washington
Certified - 2009



Len Foote Hike Inn
Dawsonville, Georgia
Gold - 2004



CityFlats
Holland, Michigan
Gold - 2009



Orchard Garden
San Francisco, California
Certified - 2007



Palazzo
Las Vegas, Nevada
Silver - 2008



Proximity Hotel
Greensboro, North Carolina
Platinum - 2008



Snowmass
Aspen, Colorado
Silver - 2005



Starwood Element
Lexington, Massachusetts
Gold - 2008



The Ambrose
Santa Monica, California
Silver - 2008



Callaway Gardens
Pine Mountain, Georgia
Certified - 2007



Unity Village Hotel
Kansas City, Missouri
Silver - 2007

Avalon Hotel

Portland, Oregon
Silver - 2008

Gaia Napa Valley

Napa, California
Gold - 2007

Hotel Terra

Teton Village, Wyoming
Silver - 2008

Vancouver Hotel

Vancouver, Washington
Certified - 2006

University of Maryland Inn

Adelphi, Maryland
Certified - 2005

Hyatt Olive 8

Seattle, Washington
Certified - 2009

Len Foote Hike Inn

Dawsonville, Georgia
Gold - 2004

CityFlats

Holland, Michigan
Gold - 2009

85%

Orchard Garden

San Francisco, California
Certified - 2007

Palazzo

Las Vegas, Nevada
Silver - 2008

Proximity Hotel

Greensboro, North Carolina
Platinum - 2008

Snowmass

Aspen, Colorado
Silver - 2005

similar

Starwood Element

Lexington, Massachusetts
Gold - 2008

The Ambrose

Santa Monica, California
Silver - 2008

Callaway Gardens

Pine Mountain, Georgia
Certified - 2007

Unity Village Hotel

Kansas City, Missouri
Silver - 2007



**missed
opportunities**

Sustainable Sites

- Credit 5.2 Maximize Open Space
- Credit 4.3 Alternative Transportation, Low-Emitting and Fuel-Efficient Vehicles
- Credit 6.2 Stormwater, Quality

Water Efficiency

- Credit 1.2 Water Efficient Landscaping
No Potable Use or No Irrigation
- Credit 2 Innovative Wastewater Technologies

Energy & Atmosphere

- Credit 2 On-Site Renewable Energy (3 points)
- Credit 5 Measurement & Verification
- Credit 6 Green Power

Materials & Resources

- Credit 2.2 Construction Waste Mgmt, Divert 75%
- Credit 5.2 Regional Materials, 20%
- Credit 7 Certified Wood

Indoor Environmental Quality

- Credit 7.1 Thermal Design
- Credit 7.2 Thermal Verification

“We’ll leave the light on for you.”[®]



(...and everything else too.)



70.9_m
23.1%

TOBACCO



19.0_m
6.2%

ALCOHOL



73.7_m
24%

FOOD



7.6_m
2.5%

GAMBLING



5.8_m
1.9%

PRESCRIPTIONS



3.1_m
1.0%

BULIMIA



1.9_m
0.7%

COCAINE



1.1_m
0.4%

HALLUCINOGENS

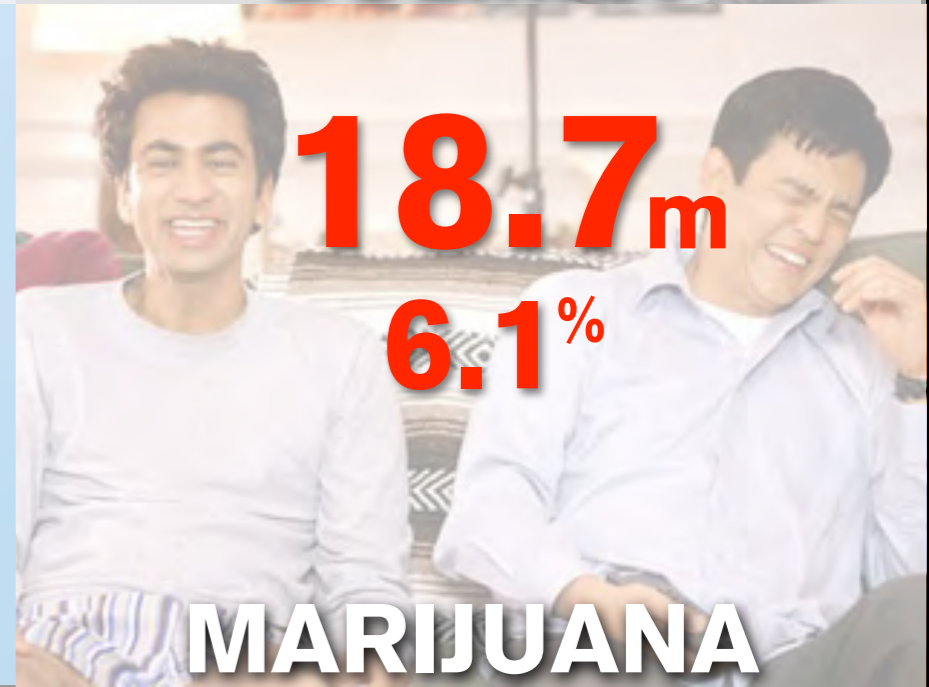

18.7_m
6.1%

MARIJUANA

fossil fuels
oil • coal • natural gas



affecting
307,000,000

100%



“I’ll quit when cigarettes cost...”

"I'll quit when gas costs..."

Regular

Special

Super+

CASH
PRICE

63.5

10/9

65.5

10/9

66.5

10/9

CREDIT

63.5

10/9

65.5

10/9

66.5

10/9

What Would You Do With
\$36 Million?
Buy Your **Powerball** Tickets
Here Today!

5

Purchase \$

17.00

SOLAR PANELS

Cost Per Watt

(1953 - 2011)

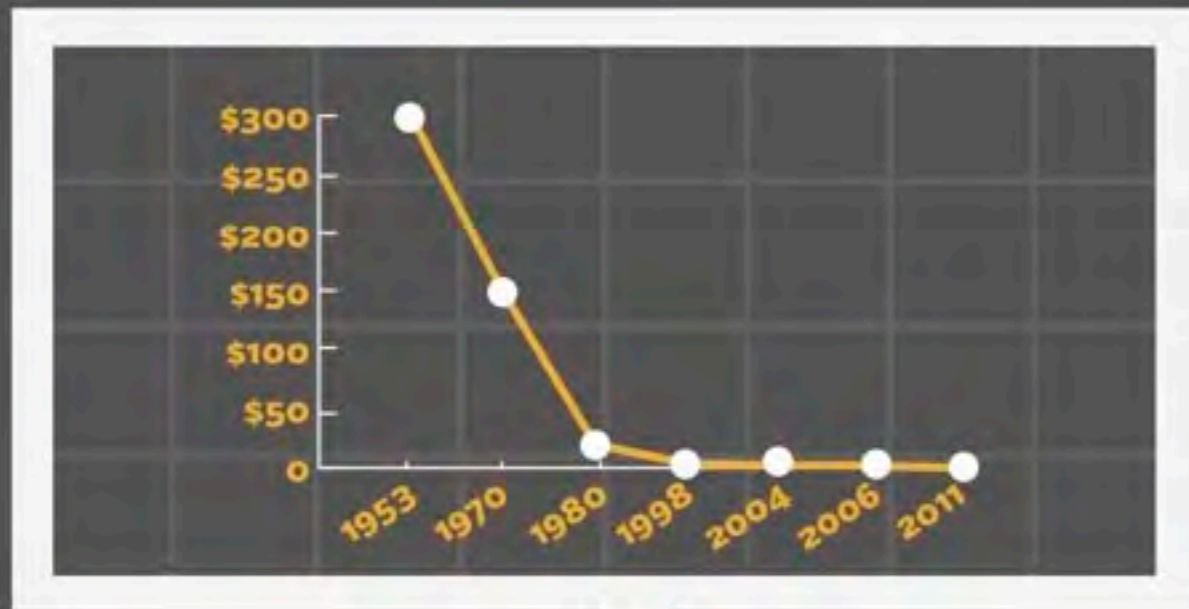

GASOLINE

Cost Per Gallon of Gas

(1953 - 2011)

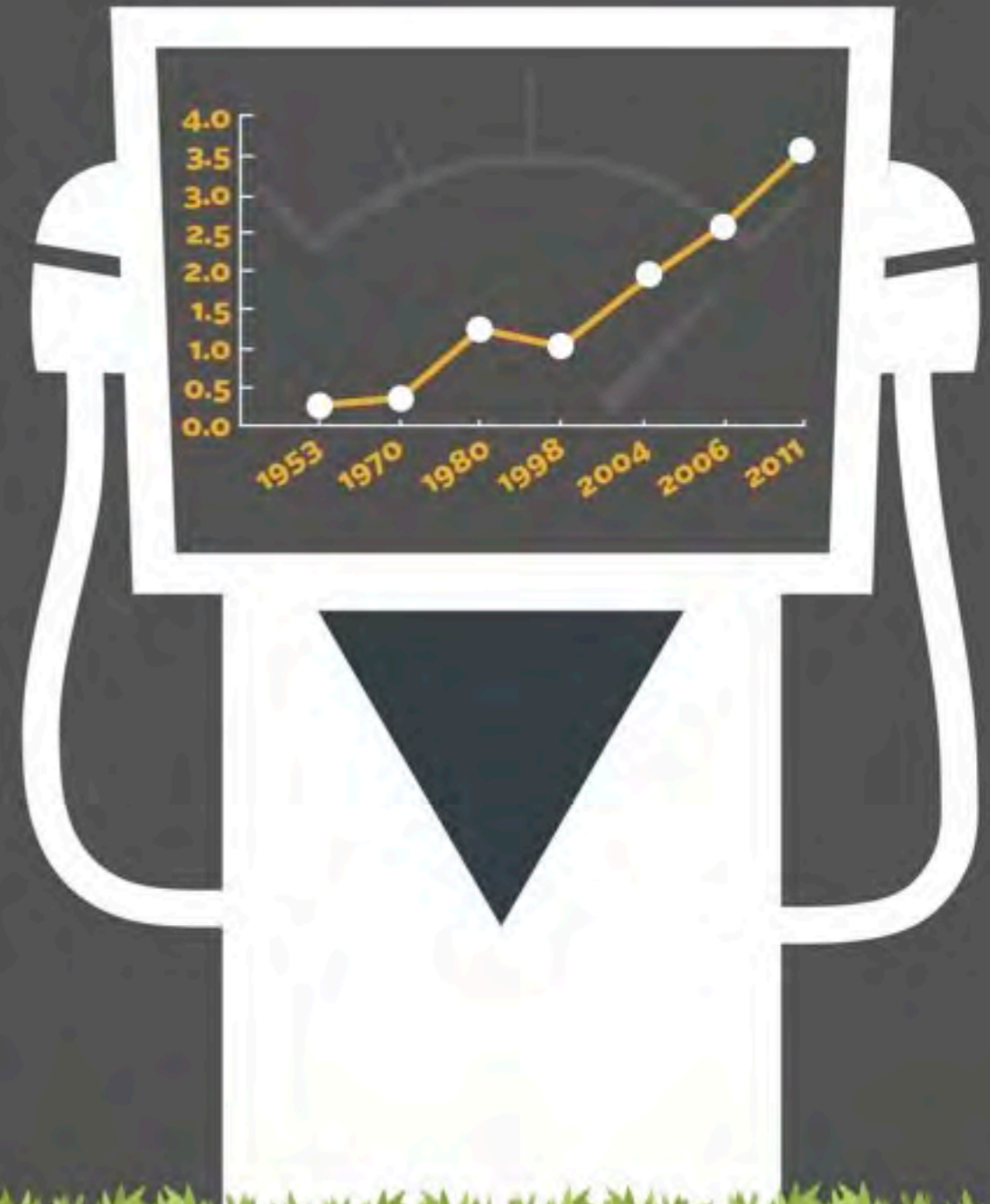

US Oil Production 1900-2010



POPULAR SCIENCE

THE FUTURE NOW

SPECIAL ISSUE

FUTURE ENERGY

GAS FROM GARBAGE
REAL FUSION
SOLAR SATELLITES
SAFE NUCLEAR
AND
THE LAST DROPS OF OIL



PLUS

How to Buy a Space Shuttle »»

Superfast Flying Submarine »»

Ferrari Goes Off-Road »» Hottest. Pepper. Ever. »»

JULY 2011 US\$4.99



Ferrari goes Off-Road »» Hottest. Pepper. Ever. »»



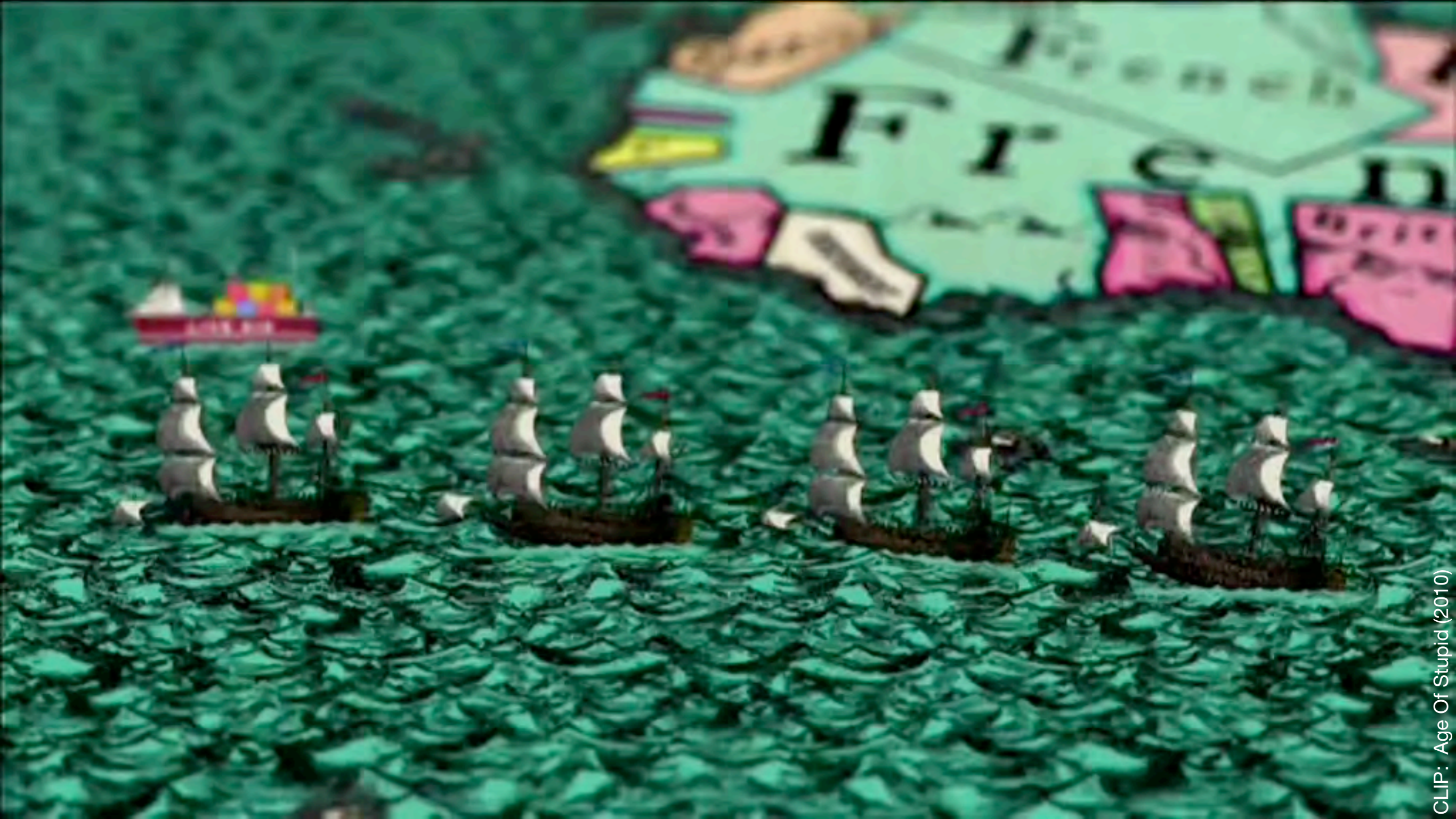

Anosognosia

/ano·sog·no·sia/ (an-o"so-no'zhah)

a condition in which a person who suffers disability seems unaware of the existence of his or her disability.

ROOMS

GUESTS

OPERATIONS

COMMON

BACK OF HOUSE

LANDSCAPE

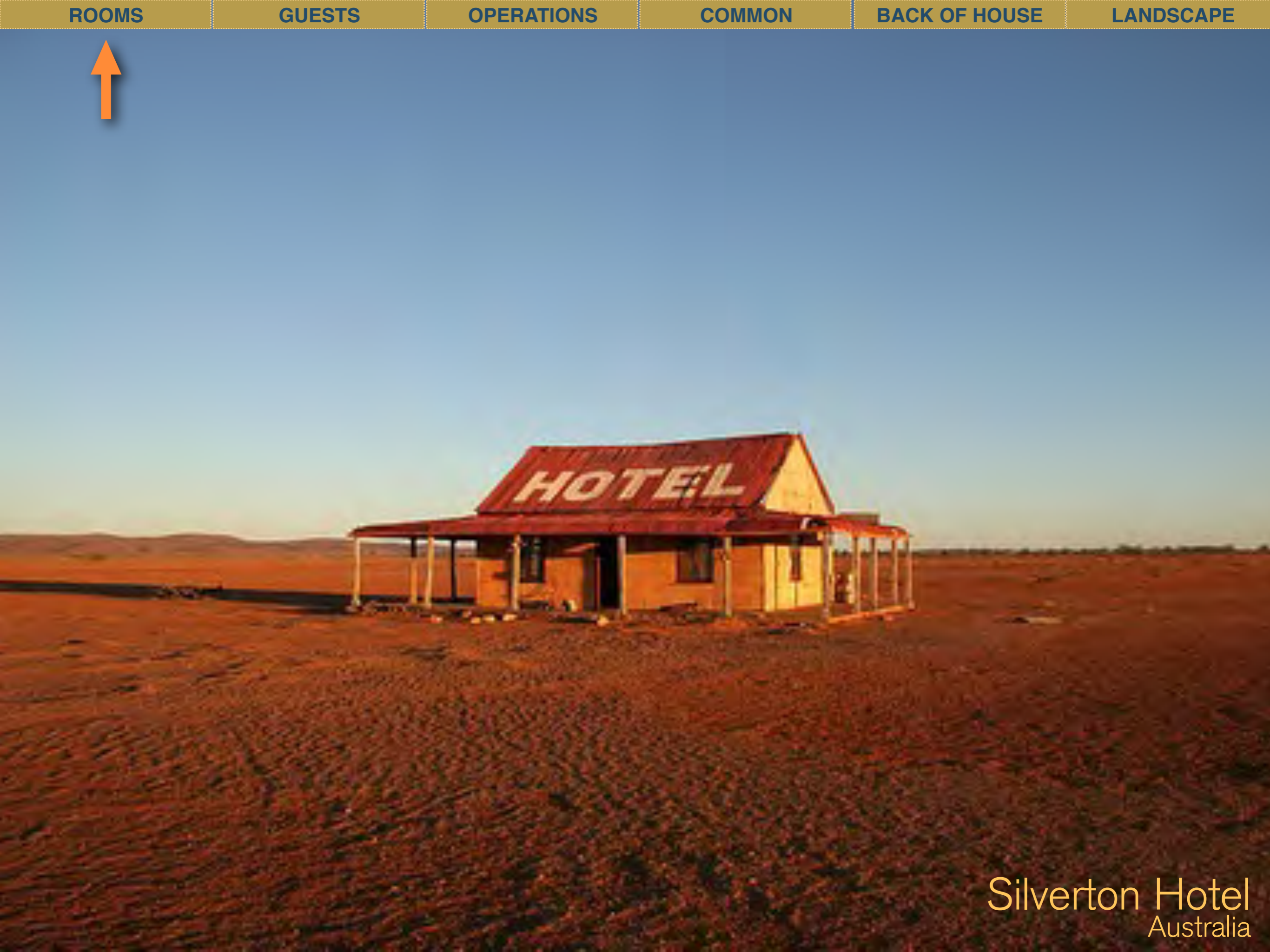

Silvertown Hotel
Australia



ROOMS



FINISHES

Recycled, non-toxic, locally sourced, sustainable.

TASK LIGHTS

Only light the work areas to save energy.

KILL SWITCH

Turn off all electronics when not in use.

CABINETRY

Use formaldehyde free cabinets & FSC or bamboo doors.

MINI BAR

Organic, natural, healthy foods.

FLOORING

Hard flooring doesn't trap allergens.

LINENS

Organic, chemical free & non-synthetic.

CLEANERS

Non toxic cleaners.

GREEN HOTEL ROOM





DON'T TREAT ALL ROOMS THE SAME



NORTH

WEST

SHADE SOUTH & WEST WINDOWS





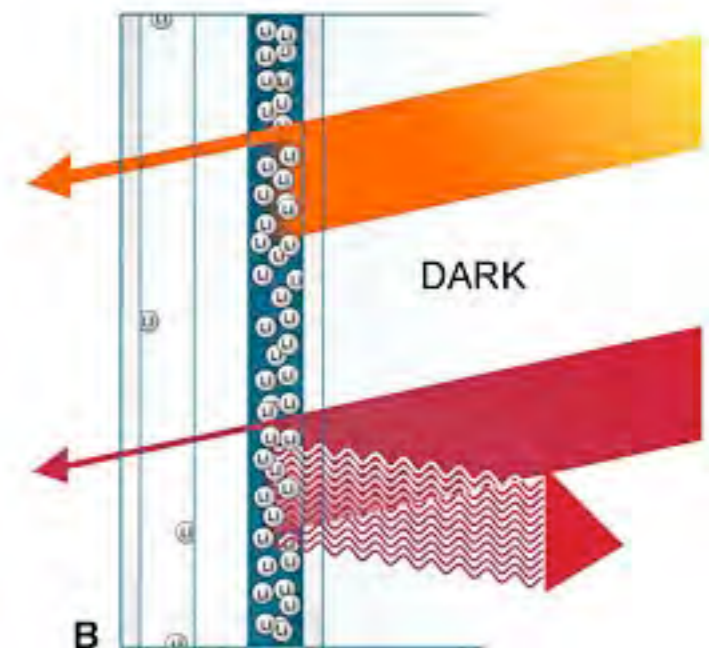
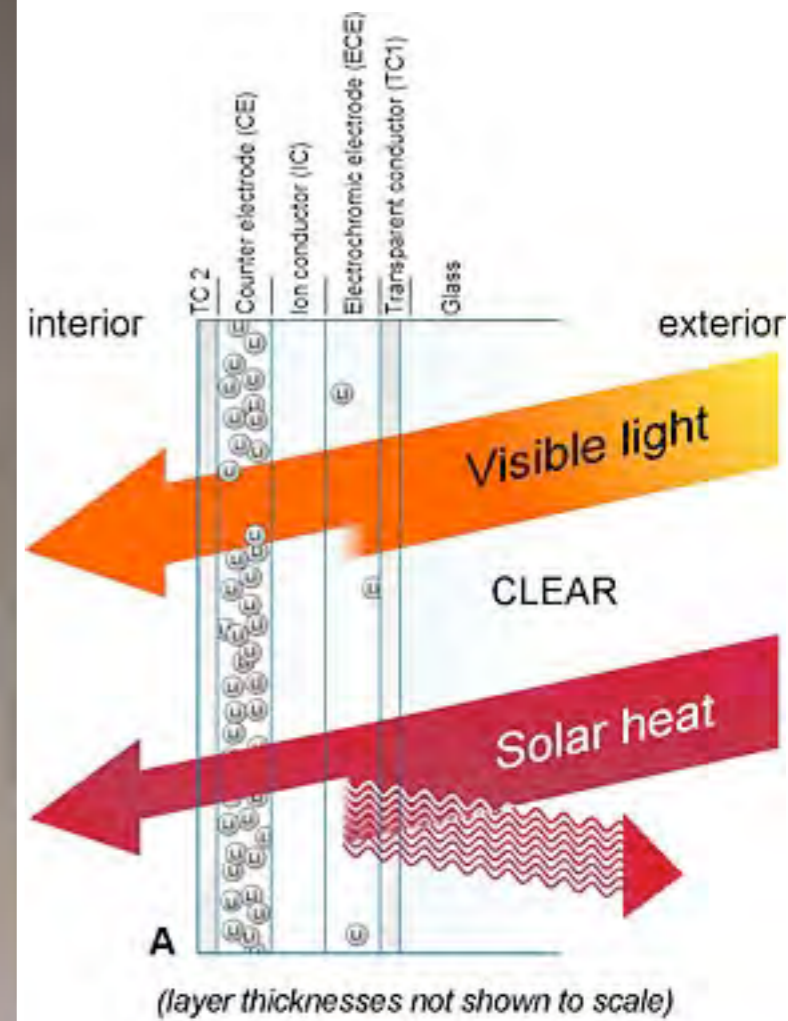







\$

3000



each room uses **2000** cards a year



key card materials add up to:



pounds/yr/hotel

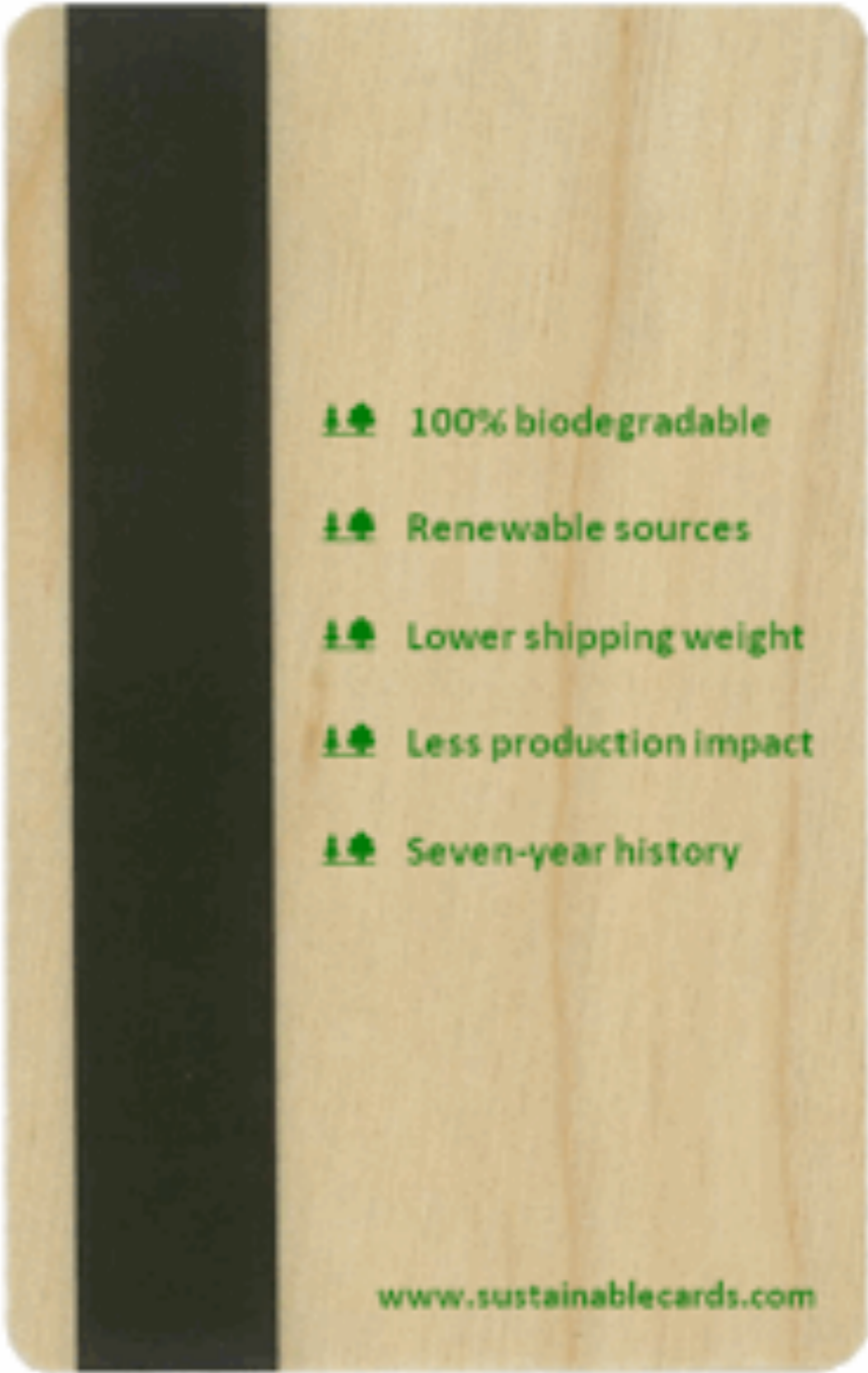

green key™



recyclable keycard

$$\sqrt{9}$$

$$3 \times 2$$

$$7 - 2$$

$$5 - 3$$

$$2 + 2$$

$$1$$



40%

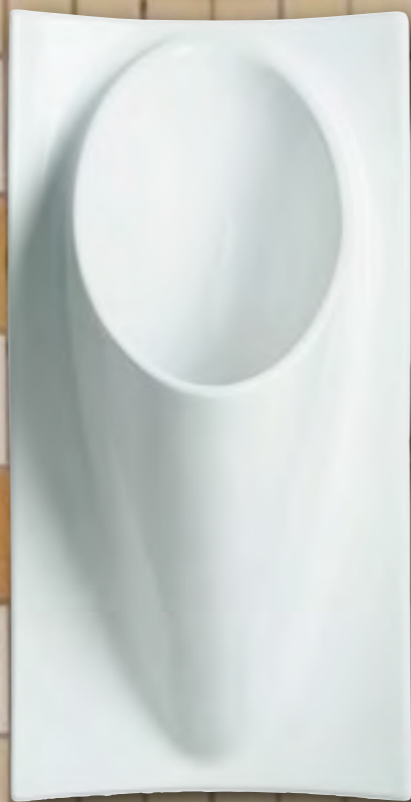
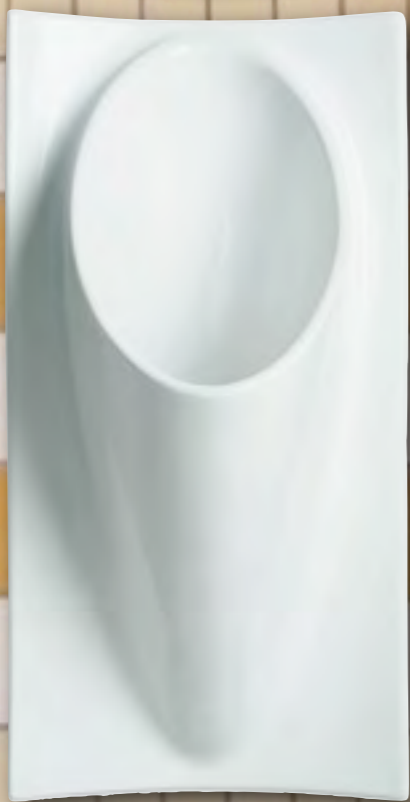

SHOWER SAVINGS



NOTICE
EMPLOYEES
MUST WASH
HANDS BEFORE
RETURNING
TO WORK



EMPLOYEES
MUST WASH
BOTH HANDS.

 **ENERGY SAVINGS**

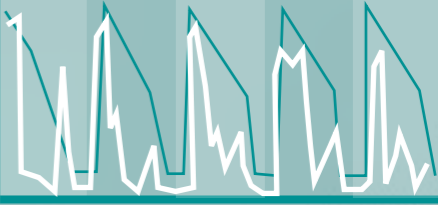
You've saved enough for a free drink!

WATER SAVINGS

100% of urine diverted into garden



DEHYDRATION
2.7 pH
You are severely dehydrated. Double your fluid intake.

BLOOD ALCOHOL
.06 bac
Not quite drunk yet, but you probably should not drive.

VITAMIN D
<10 pg/ml
You need more Vitamin D. How about a glass of milk?

THIS FLUSH SPONSORED BY:

You've diverted **5** gallons of fresh water & fertilized **15** square feet of garden

TONIGHT  TOMORROW  **78°**

FRIDAY, 01 MAY 2015 01:47 AM SUNSET: 07:12 PM 83°H / 27°L 



New York City



ENERGY SAVINGS

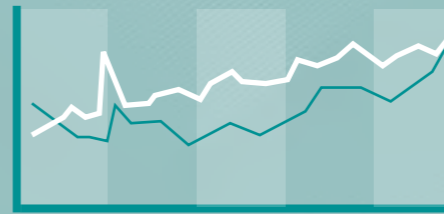

You've saved enough for a free drink!

WATER SAVINGS

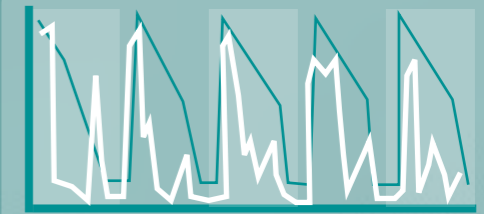

100% of urine diverted into garden

DEHYDRATION

2.7 pH

You are severely dehydrated. Double your fluid intake.

BLOOD ALCOHOL

.06 bac

Not quite drunk yet, but you probably should not drive.

VITAMIN D

<10 pg/ml

You need more Vitamin D. How about a glass of milk?

THIS FLUSH SPONSORED BY:



You've diverted **5** gallons of fresh water & fertilized **15** square feet of garden

TONIGHT



SUNSET: 07:12 PM

TOMORROW



83°H / 27°L

AccuWeather.com

FRIDAY, 01 MAY 2015 01:47 AM

EMPLOYEES MUST WASH BOTH HANDS.

Los Angeles

EMPLOYEES
MUST WASH
BOTH HANDS.

EPA WaterSense

ENERGY SAVINGS
You've saved enough for a free drink!

WATER SAVINGS
100% of urine diverted into garden



DEHYDRATION
2.7 pH
You are severely dehydrated. Double your fluid intake.

BLOOD ALCOHOL
.06 bac
Not quite drunk yet, but you probably should not drive.

VITAMIN D
<10 pg/ml
You need more Vitamin D. How about a glass of milk?

THIS FLUSH SPONSORED BY:

You've diverted **5** gallons of fresh water & fertilized **15** square feet of garden

TONIGHT  TOMORROW  **78°**

FRIDAY, 01 MAY 2015 01:47 AM
SUNSET: 07:12 PM 83°H / 27°L

AccuWeather.com



Chicago



ENERGY SAVINGS

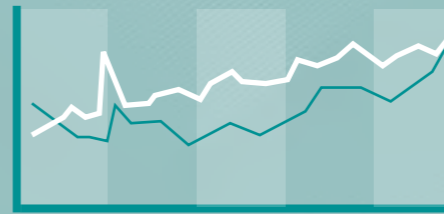

You've saved enough for a free drink!

WATER SAVINGS

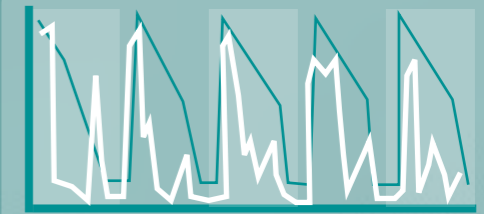

100% of urine diverted into garden

DEHYDRATION

2.7 pH

You are severely dehydrated. Double your fluid intake.

BLOOD ALCOHOL

.06 bac

Not quite drunk yet, but you probably should not drive.

VITAMIN D

<10 pg/ml

You need more Vitamin D. How about a glass of milk?

THIS FLUSH SPONSORED BY:



You've diverted **5** gallons of fresh water & fertilized **15** square feet of garden

TONIGHT



SUNSET: 07:12 PM

TOMORROW



83°H / 27°L

AccuWeather.com

FRIDAY, 01 MAY 2015 01:47 AM

EMPLOYEES
MUST WASH
BOTH HANDS.



Paris

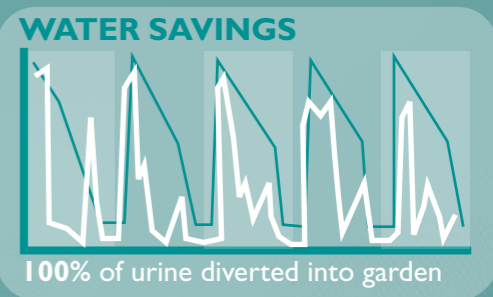
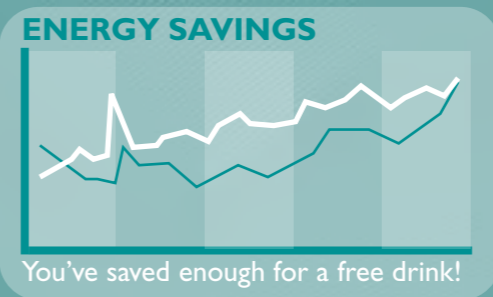

DEHYDRATION
2.7 pH
 You are severely dehydrated. Double your fluid intake.

BLOOD ALCOHOL
.06 bac
 Not quite drunk yet, but you probably should not drive.

VITAMIN D
<10 pg/ml
 You need more Vitamin D. How about a glass of milk?

THIS FLUSH SPONSORED BY:

You've diverted **5** gallons of fresh water & fertilized **15** square feet of garden

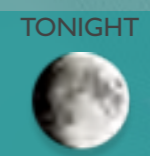

FRIDAY, 01 MAY 2015 01:47 AM

SUNSET: 07:12 PM 83°H / 27°L

AccuWeather.com



San Francisco

EMPLOYEES
 MUST WASH
 BOTH HANDS.

Never...
something...
once...
because...
what you wanted.
Halcyon
W HO SEEK
KNOWLEDGE
SEEK THE ONENESS
AND THERE YOU WILL
FIND A CLEAR MIRROR
ALREADY WA
I love you, not for
what you are, but for
when I am
with you.
Roy Croft
Dream on,
dreams
of not
and

EMPLOYEES
MUST WASH
BOTH HANDS.

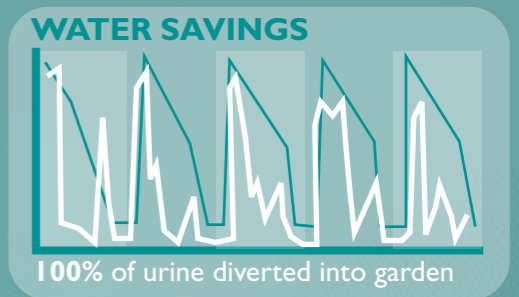

DEHYDRATION

2.7 pH
You are severely dehydrated.
Double your fluid intake.

BLOOD ALCOHOL

.06 bac
Not quite drunk yet, but you
probably should not drive.

VITAMIN D

<10 pg/ml
You need more Vitamin D.
How about a glass of milk?

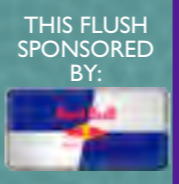

You've diverted
5 gallons of fresh water &
fertilized **15** square feet of garden



FRIDAY, 01 MAY 2015 01:47 AM

SUNSET: 07:12 PM 83°H / 27°L

AccuWeather.com



Portland



ENERGY SAVINGS

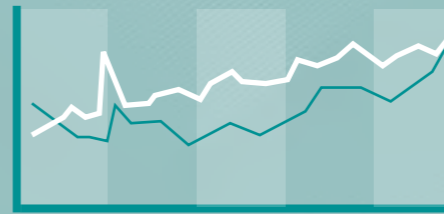

You've saved enough for a free drink!

WATER SAVINGS

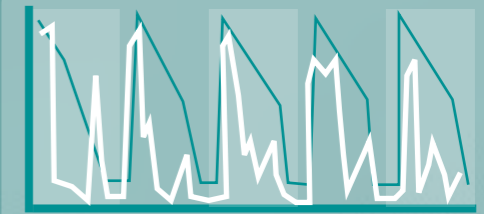

100% of urine diverted into garden

DEHYDRATION

2.7 pH

You are severely dehydrated. Double your fluid intake.

BLOOD ALCOHOL

.06 bac

Not quite drunk yet, but you probably should not drive.

VITAMIN D

<10 pg/ml

You need more Vitamin D. How about a glass of milk?

THIS FLUSH SPONSORED BY:



You've diverted **5** gallons of fresh water & fertilized **15** square feet of garden

TONIGHT



SUNSET: 07:12 PM

TOMORROW



83°H / 27°L

AccuWeather.com

FRIDAY, 01 MAY 2015 01:47 AM

Middle East



ENERGY SAVINGS



You've saved enough for a free drink!

WATER SAVINGS

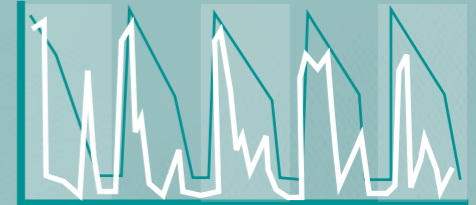

100% of urine diverted into garden

THIS FLUSH
SPONSORED
BY:



DEHYDRATION

2.7 pH

You are severely dehydrated.
Double your fluid intake.

BLOOD ALCOHOL

.06 bac

Not quite drunk yet, but you
probably should not drive.

VITAMIN D

<10 pg/ml

You need more Vitamin D.
How about a glass of milk?

FRIDAY, 01 MAY 2015 01:47 AM

SAMSUNG

Your House





the minibar is an opportunity



HEALTHY FOOD IN MINIBAR



 Recycle

 Compost

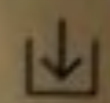
 Landfill

SMART

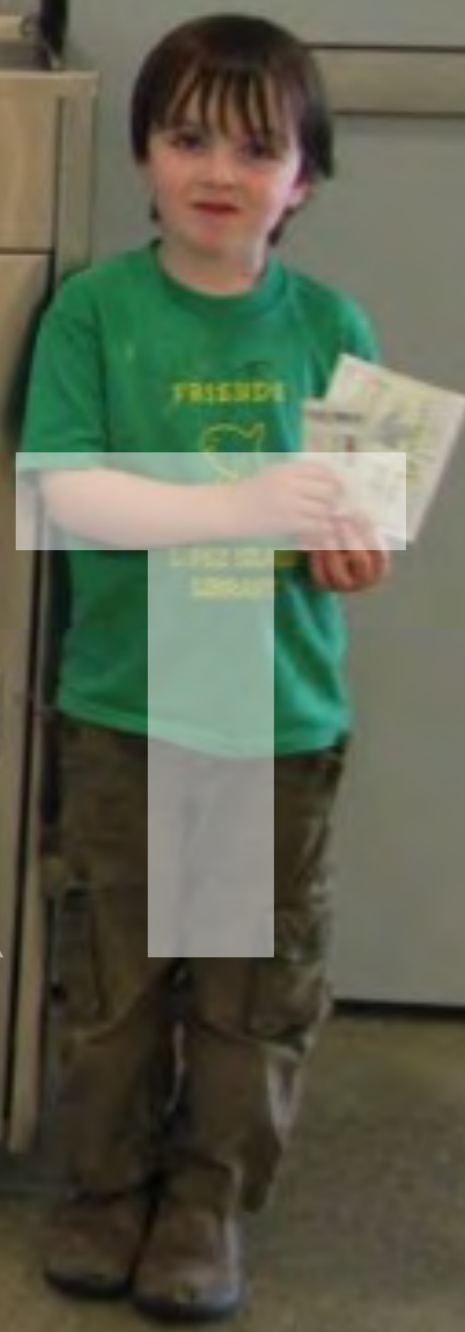



24
HOUR

FITNESS

DUMWB

POINT LO...
HANDICAP...
TO UPPER...
LOCKED...
24 HOUR...

in-room recycling





in-room recycling

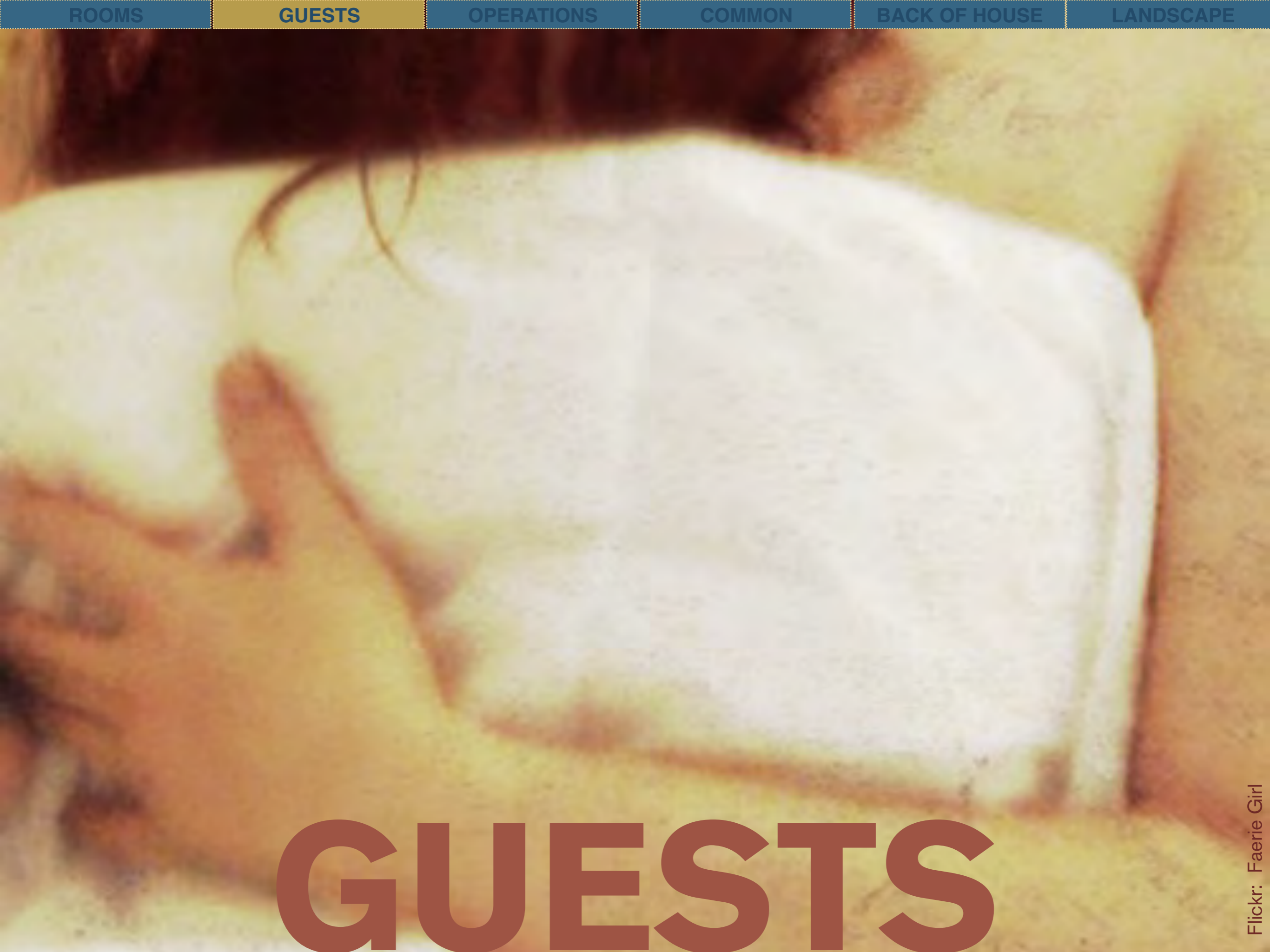

GUESTS



same price?



NOT ALL GUESTS ARE EQUAL





HOT



A
S
S

energy & water use

200%

MORE IN HOTELS

worldwide

27,397,200

bottles a day











LATHER®
bamboo lemongrass hair wash
The fresh, natural essence of lemongrass blended with the strengthening power of bamboo make this mild hair wash perfect for daily use.
modern apothecary

LATHER®
bamboo lemongrass crème rinse
This lightweight, daily detangler imparts the fresh, natural essence of lemongrass and promotes healthy, silky hair.
modern apothecary

LATHER®
bamboo lemongrass body wash
A light body cleanser that rejuvenates skin with bamboo extract and leaves a hint of fresh, natural lemongrass.
modern apothecary

LATHER®
bamboo lemongrass moisturizer
A hydrating body lotion that rejuvenates skin with bamboo extract and leaves a hint of fresh, natural lemongrass.
modern apothecary

LATHER®
bamboo lemongrass exfoliating body soap
Formulated with microbead bath oatmeal, this natural body soap exfoliates, revitalizing the skin.
modern apothecary

LATHER®
gentle face soap
A mild, natural, fragrance-free face soap that is gentle enough for even the most sensitive skin.
modern apothecary

COLOR

T.V.



TV

MOVIES

CD JUKEBOX

VIDEO PHONE

ROOM SERVICE

ECO PERFORMANCE

HOTEL DASHBOARD

ROOM CONTROLS

GUEST SERVICES

MESSAGES 2

ENERGY USAGE	
LIGHTING	1690 WATTS
MEDIA	0700 WATTS
HEAT / COOL	0210 WATTS
TOTAL	2600 WATTS
AVERAGE GUEST	3000 WATTS

WATER USAGE	
SINKS	15 GALLONS
SHOWER	20 GALLONS
- GREYWATER TOILET	07 GALLONS
TOTAL	28 GALLONS
AVERAGE GUEST	200 GALLONS

Congratulations! You've exceeded the savings for water and energy. Your air conditioner will rise 5° at 07:00 PM.
ECO TIP: The shower timer is a friendly nudge after 5 minutes.

ENERGY PRODUCTION	
FITNESS CENTER	2360 WATTS
STAIR SKIPPING	1230 WATTS
TOTAL	3590 WATTS
AVERAGE GUEST	1800 WATTS

GUEST PREFERENCES	
NEWSPAPER DELIVERY IS OFF	CHANGE
HEATER ENERGY SAVER ON	CHANGE
SHOWER TIMER IS ON	CHANGE
LINENS CHANGED 2X A WEEK	CHANGE



Welcome, **Mr. Brad Pitt**
 You've earned 1,200 Reward Center Points for your eco performance.
 You have 2 new messages. A wake up call for 06:00 AM is set.
 FRIDAY, 01 MAY 2015 08:56 AM

AccuWeather.com®

TONIGHT	TODAY
	78°
SUNSET: 07:12 PM	83°H / 27°L

TV

MOVIES

CD JUKEBOX

VIDEO PHONE

ROOM SERVICE

ECO PERFORMANCE

HOTEL DASHBOARD

ROOM CONTROLS

GUEST SERVICES

MESSAGES 2

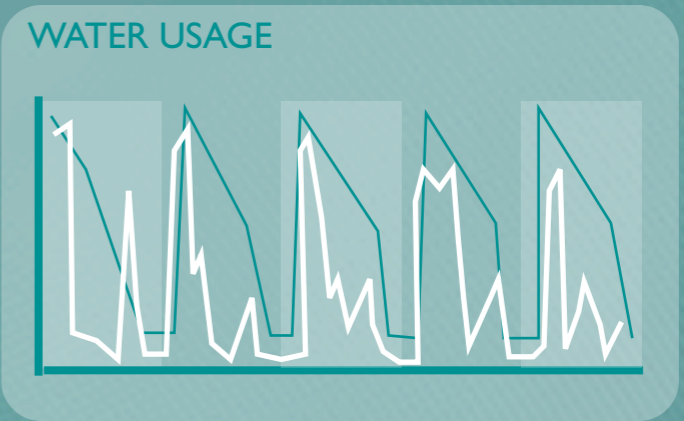
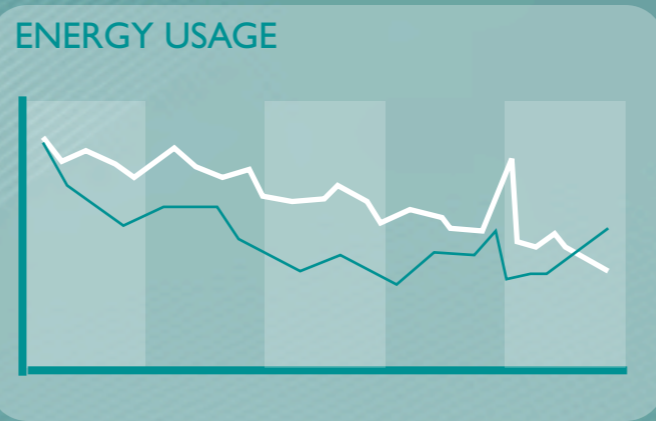

Congratulations! You've exceeded the savings for water and energy.
 Your air conditioner will rise 5° at 07:00 PM.
ECO TIP: Use the refillable metal bottle to save on plastic water bottles.



- GUEST PREFERENCES
- NEWSPAPER DELIVERY IS **OFF** CHANGE
 - HEATER ENERGY SAVER **ON** CHANGE
 - SHOWER TIMER IS **ON** CHANGE
 - LINENS CHANGED **2X** A WEEK CHANGE



Welcome, **Mr. Brad Pitt**
 You've earned **1,200** Reward Center Points for your eco performance.
 You have **2** new messages. A wake up call for **06:00 AM** is set.

FRIDAY, 01 MAY 2015 08:57 AM

AccuWeather.com®

TONIGHT	TODAY
SUNSET: 07:12 PM	83°H / 27°L

displaying energy & water feedback

20%

improvement

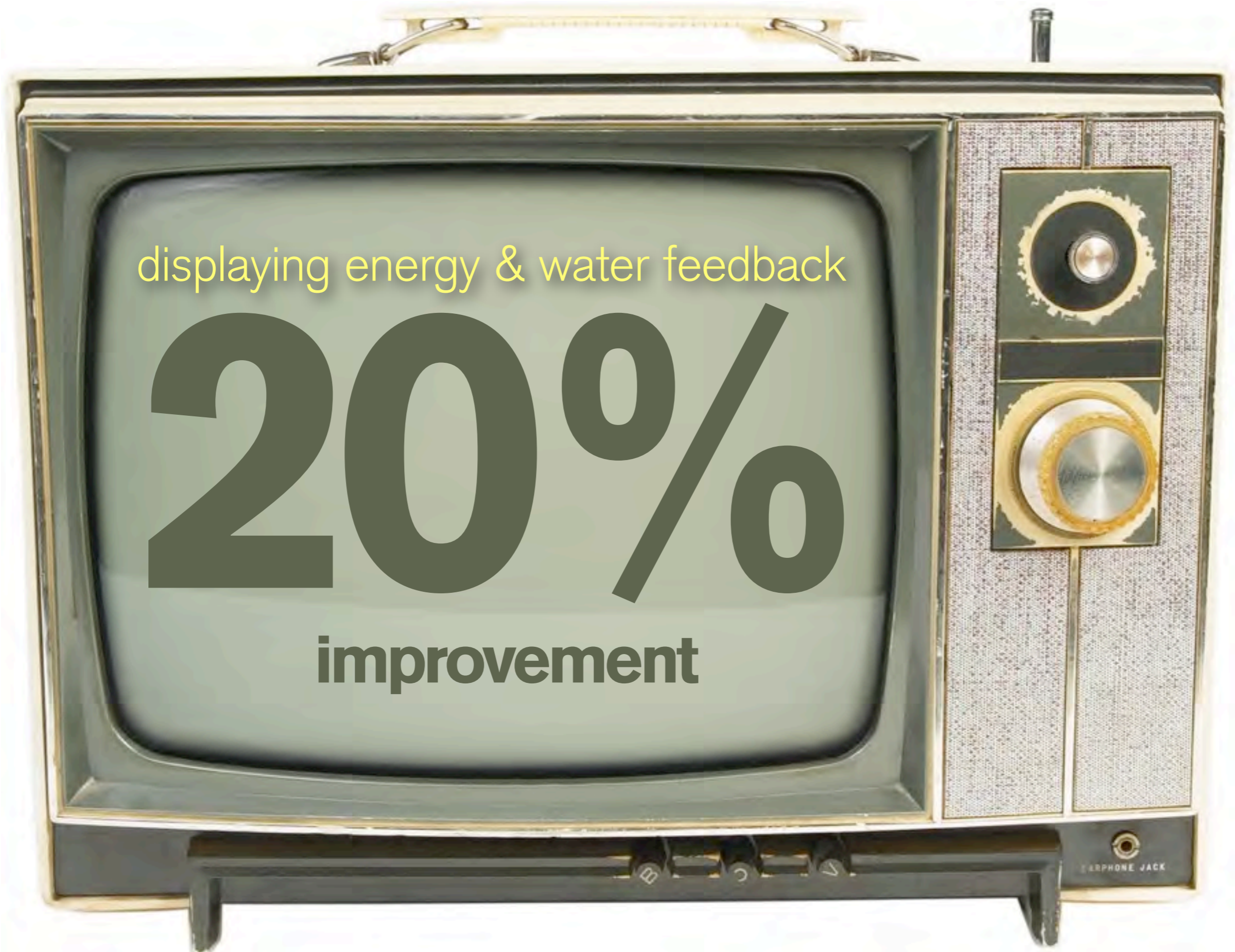



REWARD GOOD GUESTS

GIVE INCENTIVES A HEAD START

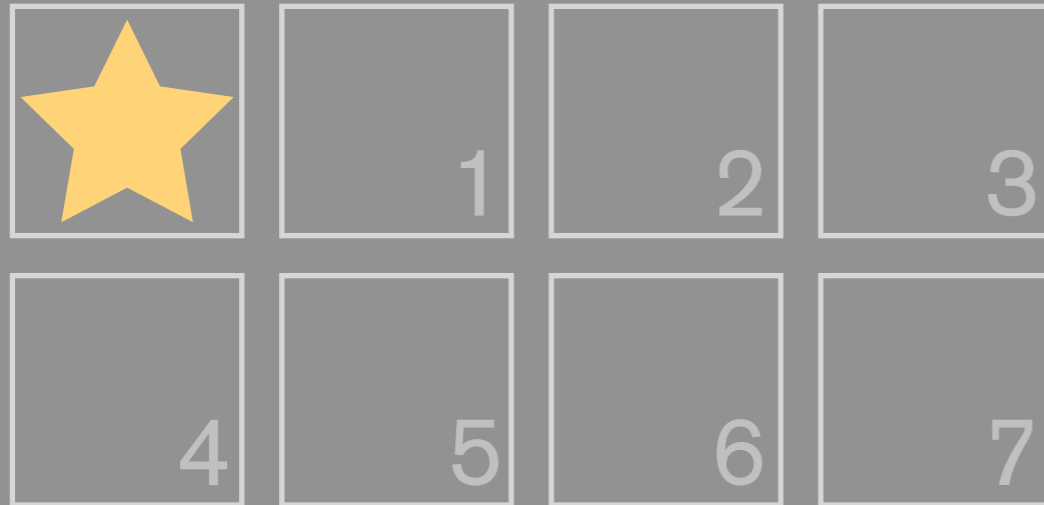

Free car wash after **8** washes

19%
returned



Free car wash after **10** washes

34%
returned

CHECKOUT. 12:00 NOON
LEAVE KEY IN ROOM

OPERATIONS



one hotel
one week

1000
families
52 weeks



Electricity

Measured in Kilowatts per hour
The kilowatt (symbol: kW), is equal to one thousand watts.

Did you know?
Most electronic devices continue to draw electricity even when turned off or left in "standby" mode. In fact, according to ENERGY STAR, the amount of electricity used nationally by idle equipment is roughly equal to the output of 17 power plants.

38 kw

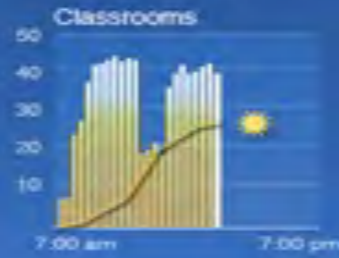

8 kw



27 kw



25 kw

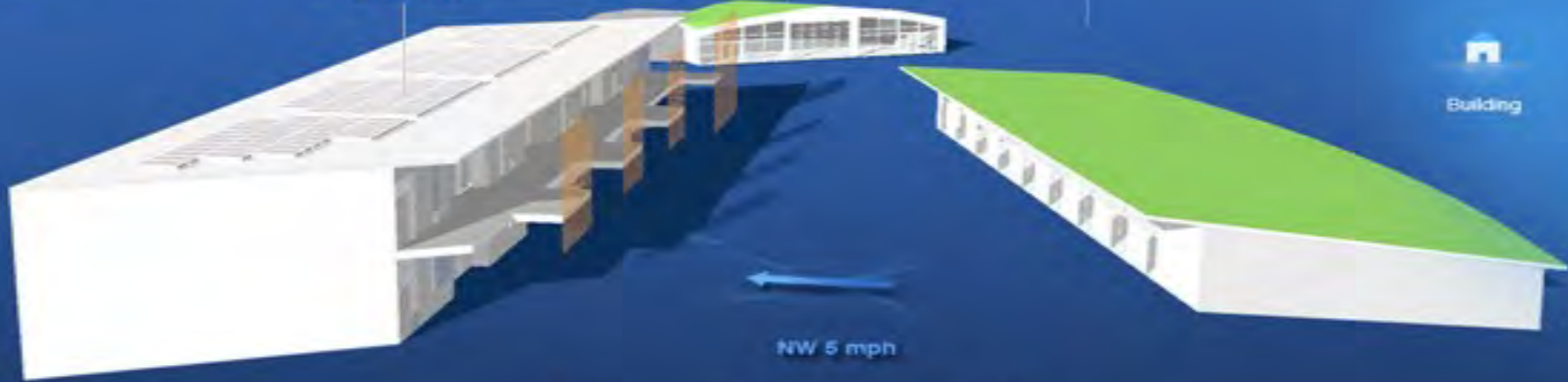

51° 58% 1 inches

7:00 am 7:00 pm 7:00 am

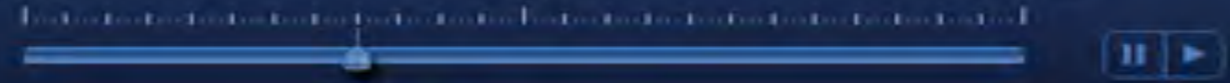

3:00 pm



Building



GreenEngage

- Green Engage Home
- Green Measure
- Measure Reports**
- Green Manage
- Google Maps
- IHG Engage Survey

Report Details

Select a property: Panama Hotel

Panama Hotel

Variance

Consumption

Need help? Take a guided Tour

Energy | Water | Waste | Show data in the range: January 2008 to December 2008 Refresh Report

Select report view: Consumption Benchmark: Export as: Excel Image

Consumption

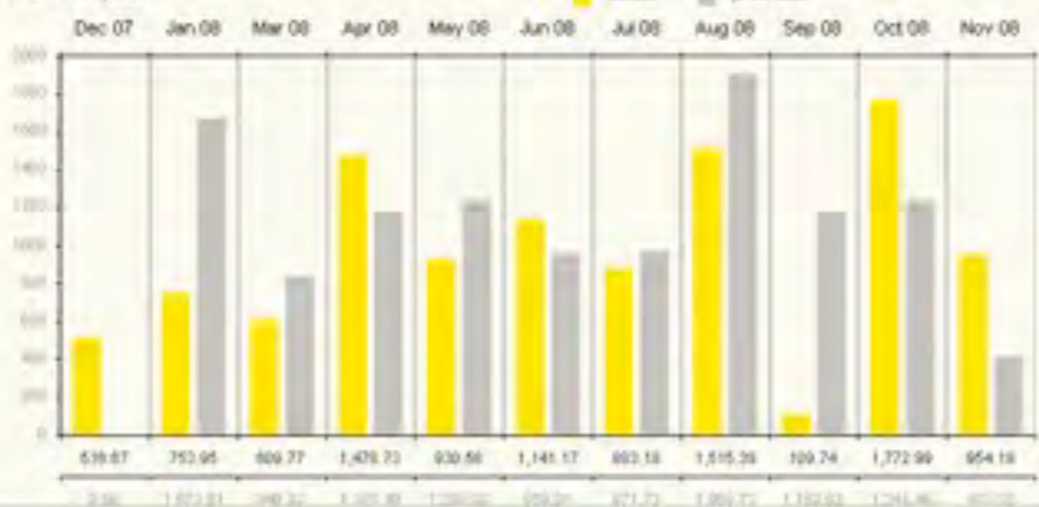

Privacy Policy | Contact Us | US Patent Pending



daily copies of USA today in hotels

1,200,000

papers

(half their circulation)



60% unread

18,197 emissions of cars

NEWSPAPER



The New York Times

AVAILABLE 7 DAYS A WEEK

PLEASE PLACE THIS SIDE OUT ON
YOUR DOORKNOB BY 1:00 AM TO
RECEIVE YOUR COMPLIMENTARY
COPY OF THE NEW YORK TIMES NO
LATER THAN 7:00 AM.



FOUR SEASONS HOTEL

Austria

NEWSPAPER



THE WALL STREET JOURNAL

AVAILABLE MONDAY - FRIDAY

PLEASE PLACE THIS SIDE OUT ON
YOUR DOORKNOB BY 1:00 AM TO
RECEIVE YOUR COMPLIMENTARY COPY
OF THE WALL STREET JOURNAL NO
LATER THAN 7:00 AM.



FOUR SEASONS HOTEL

Austria

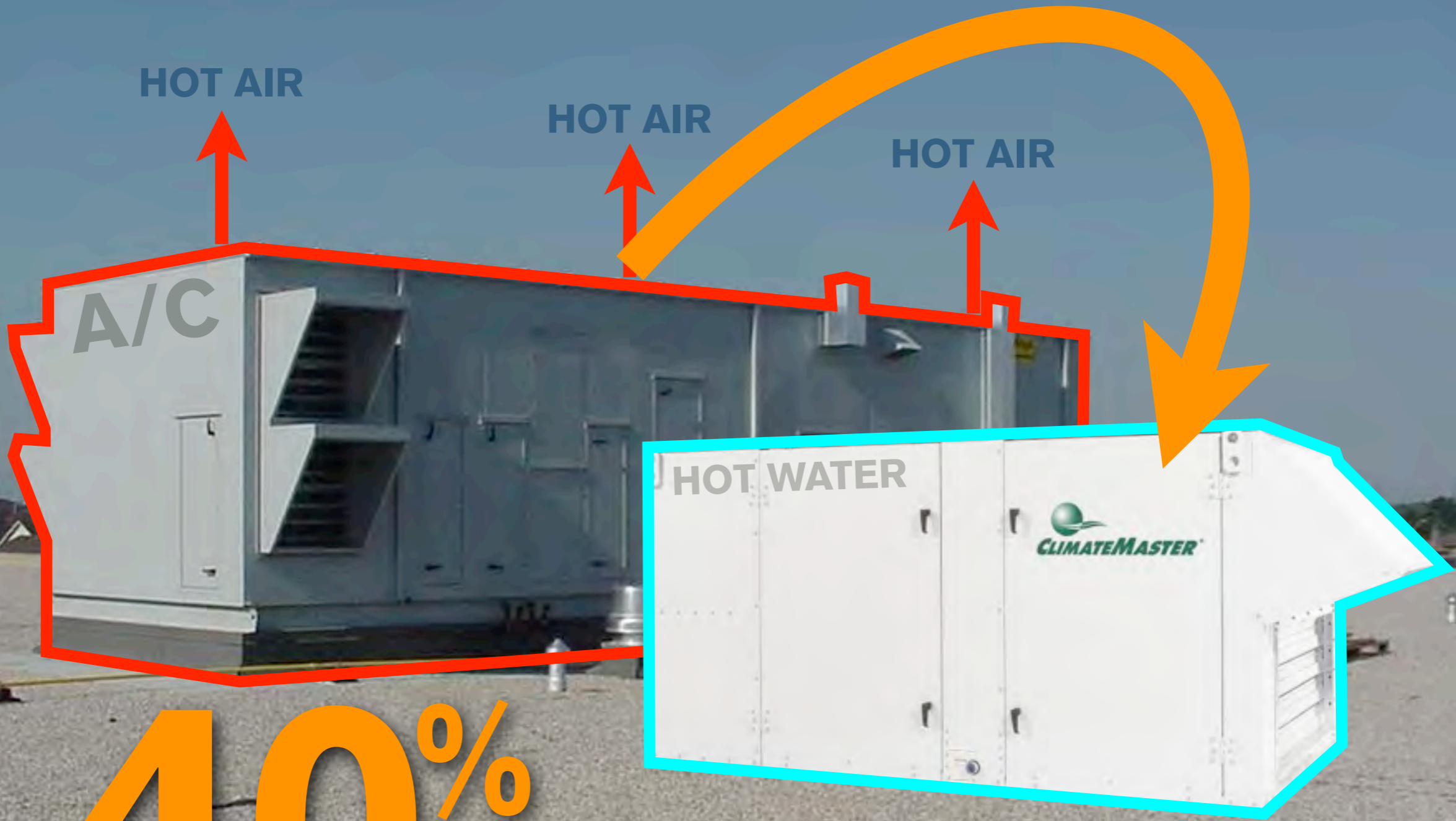

40%
off
HOT WATER BILL

central vs. package units

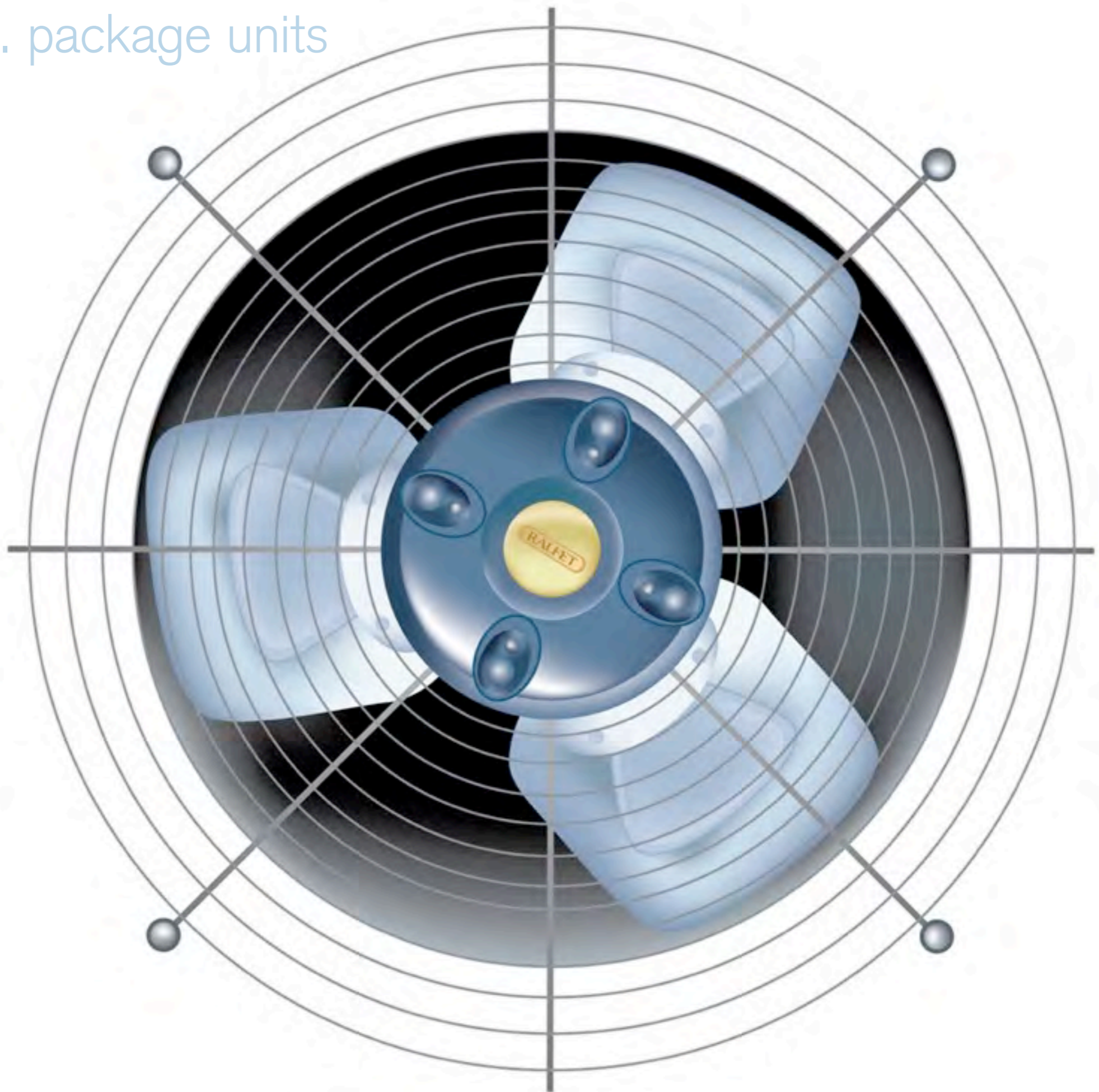

no heat = no guest

Central Plant

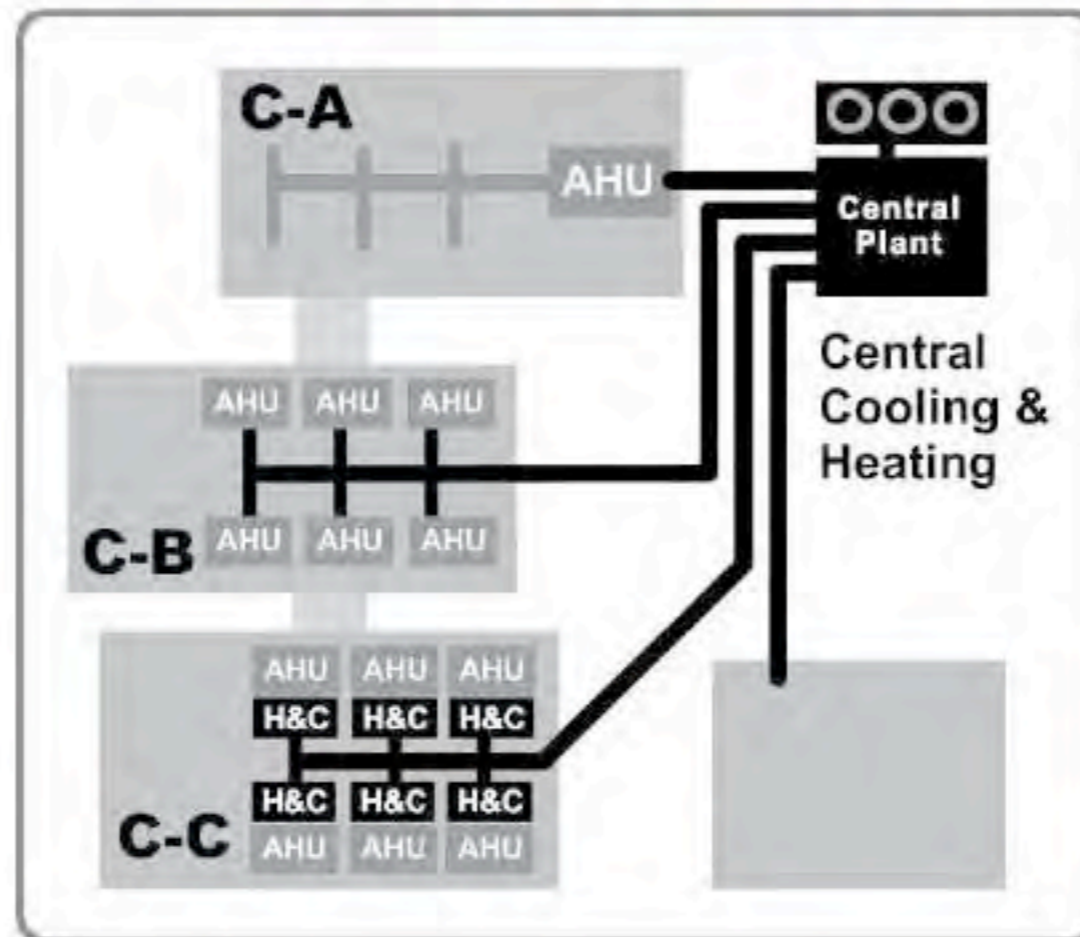

- Chiller system
- Hot water/steam
- Water-source HP

redundant, but reliable

Individual Units

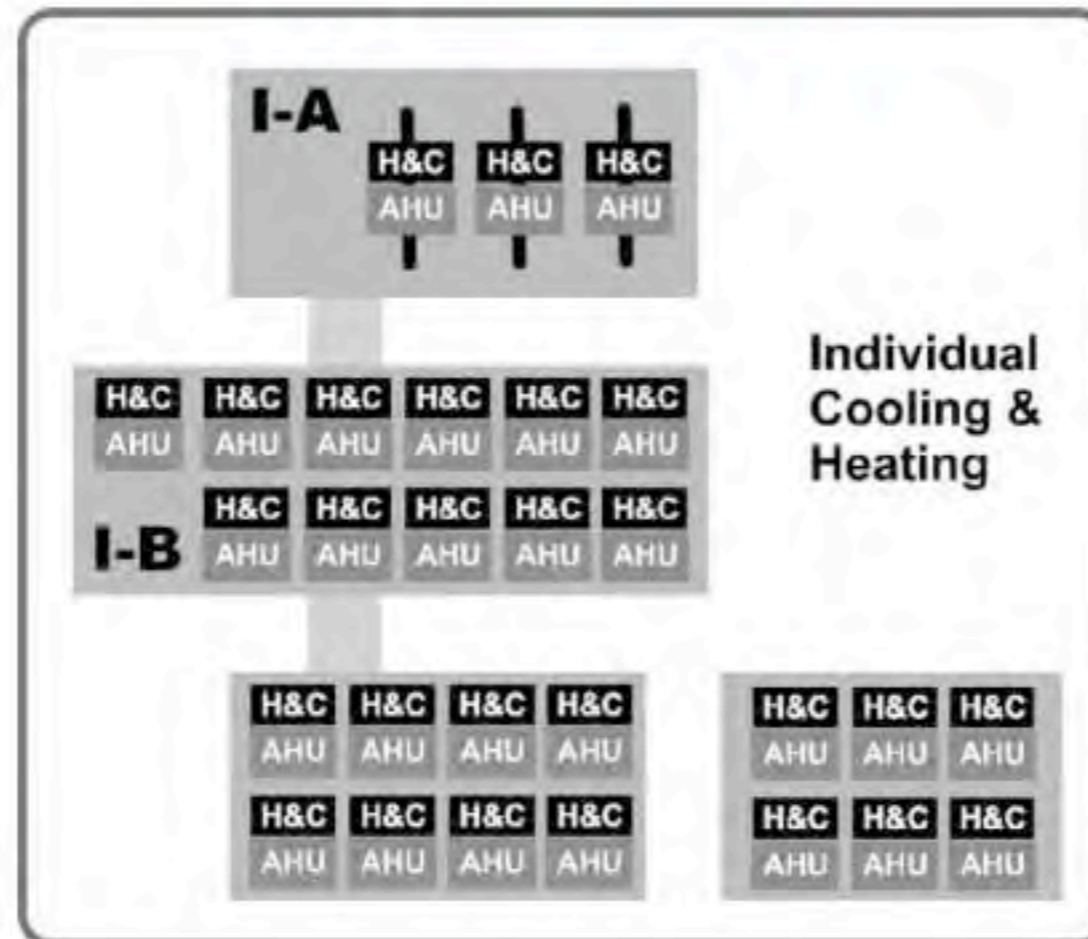

- Wall units
- Roof top units
- Split systems

Zoned Systems

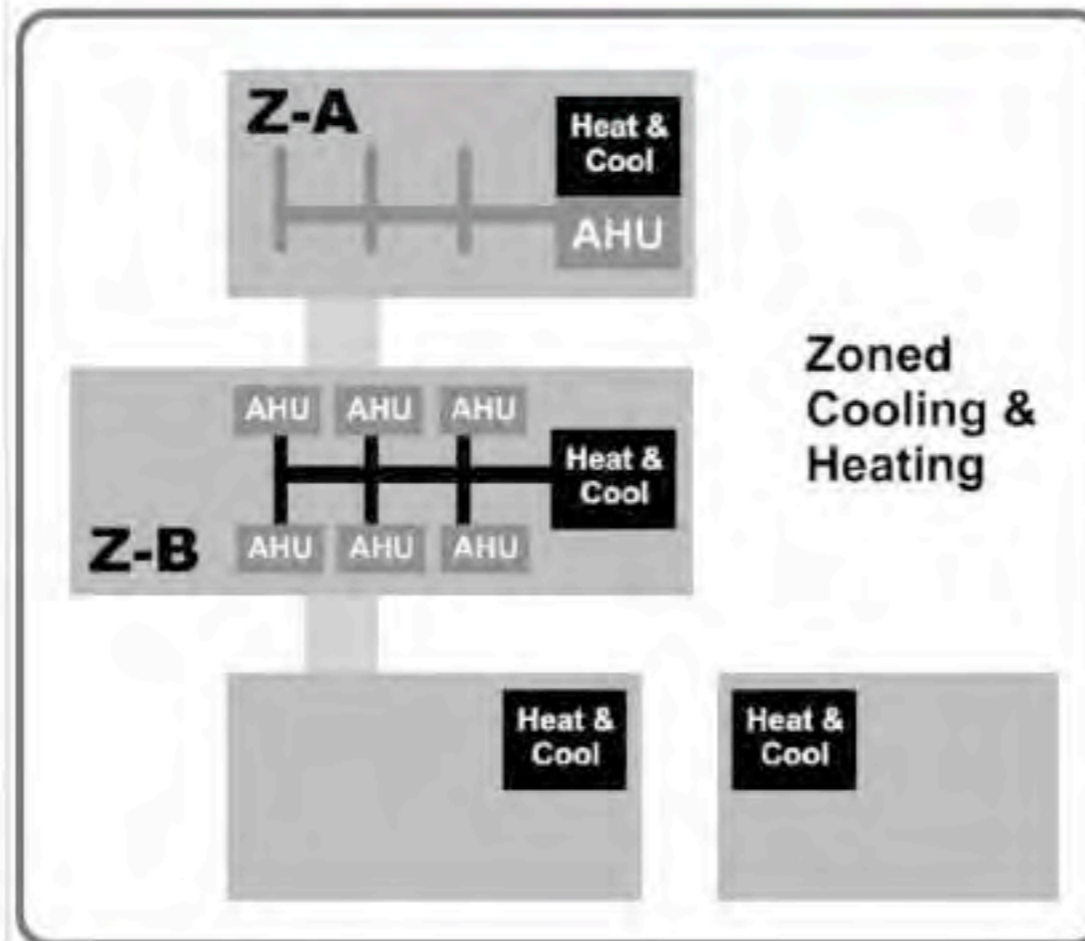

- Small chiller systems
- DX systems
- Split systems

Direct Venting into a Room - SolarSheat 1500G

How it works: The SolarSheat 1500G panel heats inside air. The amount of heat produced is based on the volume of air passing through the solar panels and the degree of sunshine. The SolarSheat is a supplemental heating system. It does not work at night. No AC electricity is required.

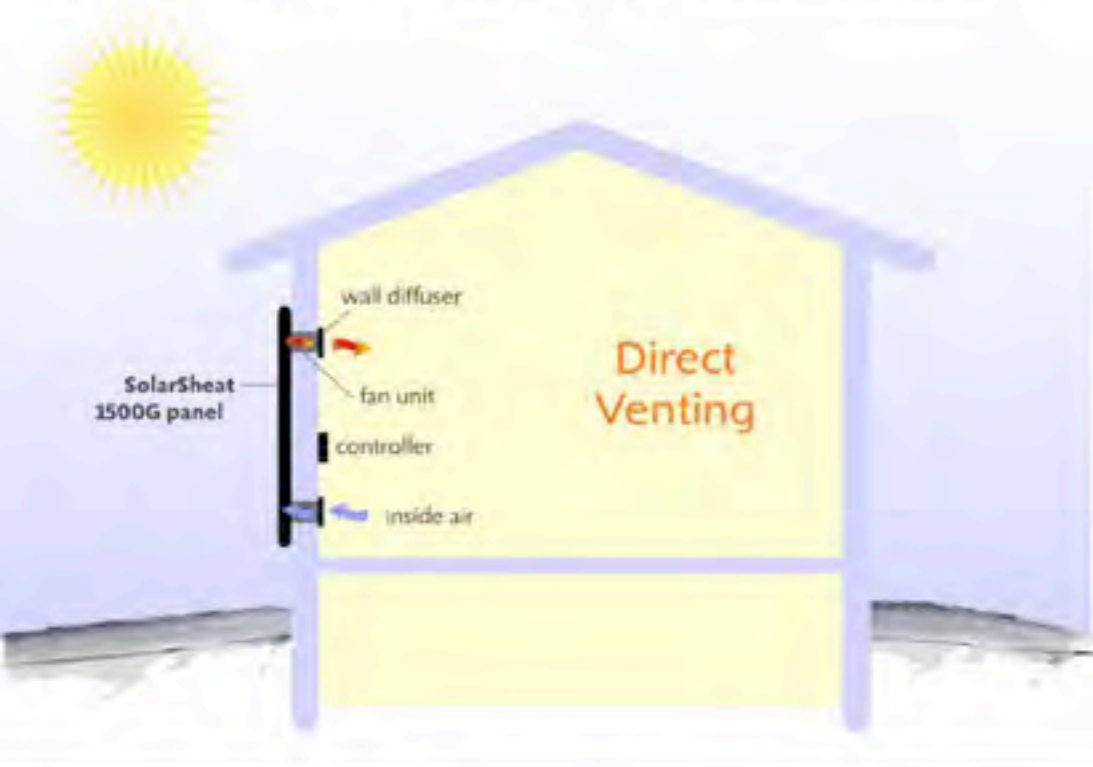

Roof Mounting - SolarSheat 1500G

How it works: The SolarSheat 1500G panel heats inside air. The amount of heat produced is based on the volume of air passing through the solar panels and the degree of sunshine. The inline fan kit can be powered by an AC/DC wall adaptor or with an additional PV cell, to keep it off the grid.



using non-toxic cleaners reduces

87%

AIRBORNE TOXINS



get rid of carpeting in the rooms

\$ **46,141,825**
spent on vacuuming

enough to power

34,829
homes

gear & flywheel assembly



rotating magnetic wheel



fixed wire coil wheel



glass protective enclosure

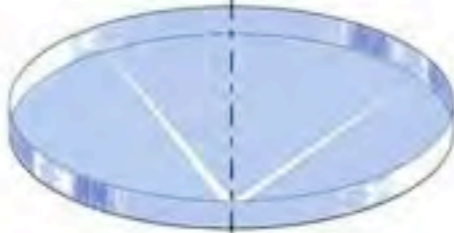

door panels & structure

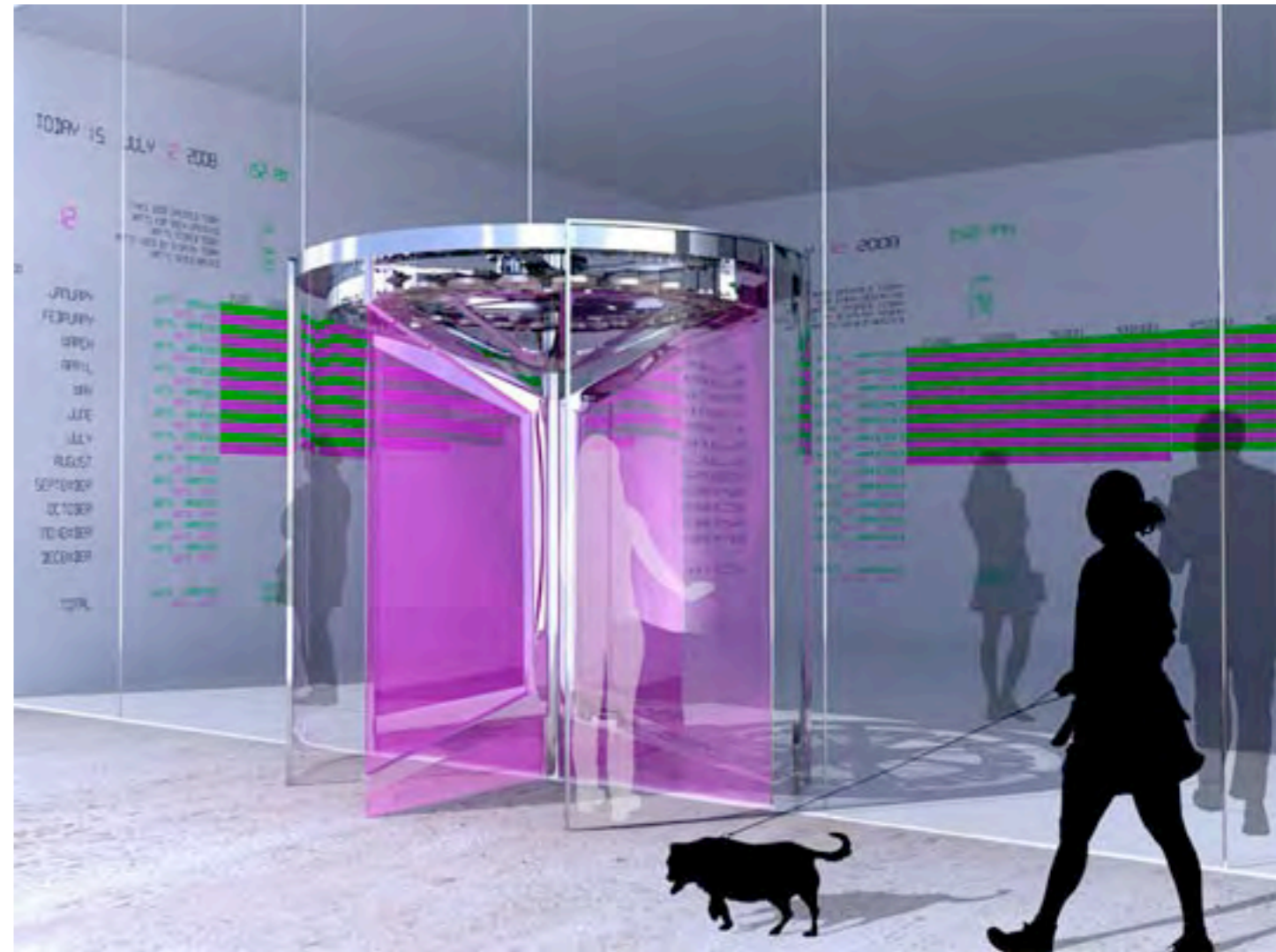
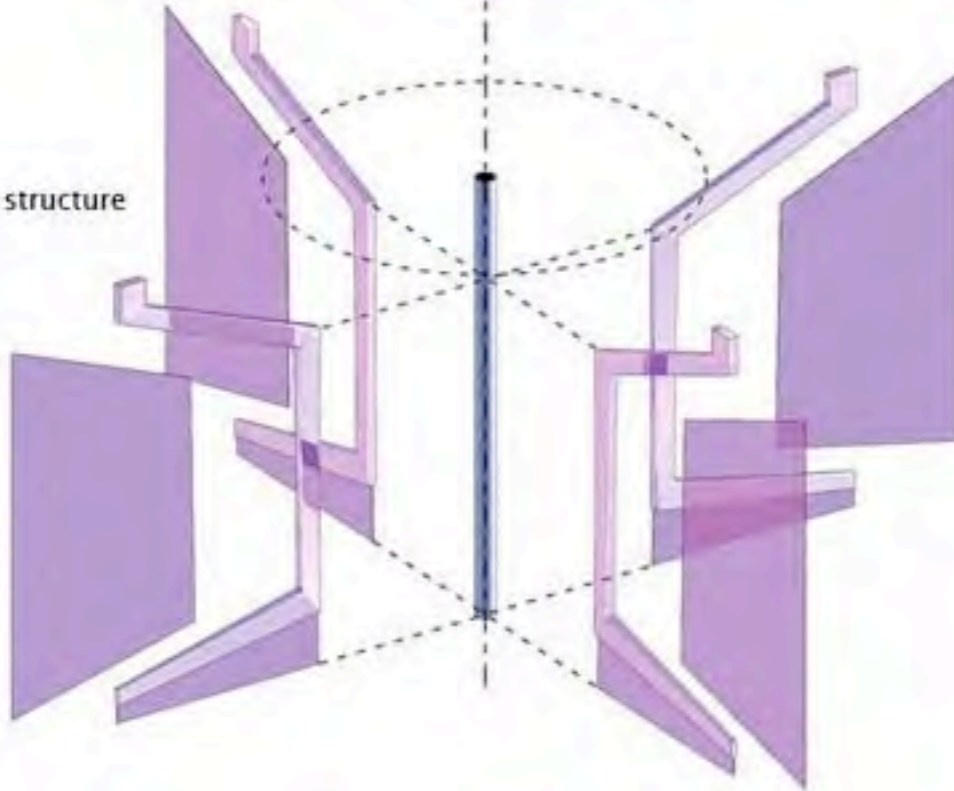



1/3
OF THE FOOD
WE BUY
WE THROW
AWAY!



COMMON AREAS



retrofit with dual flush valves

UP for liquid waste



Down for solid waste



UPGRADE TO LOW FLOW PEDAL VALVES

FAUCETS

flow
2.5
gpm

time
15
seconds

use
.625
gallons

NEW

1.5
gpf

10
seconds

.25
gallons

450 times/day **70,312** **28,125**
gal/yr gal/yr

= **45,187** gallons saved
x \$ **0.015** /gallon = \$ **678.**



collect condensate from A/C



\$130
per SIGN
per year

activesafety.com



\$ **300**
per CAB per year



30,000

hotel elevators in u.s.

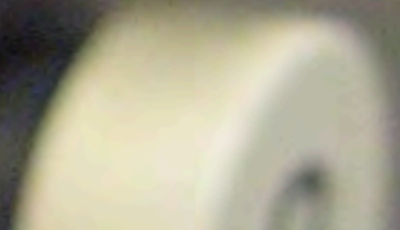
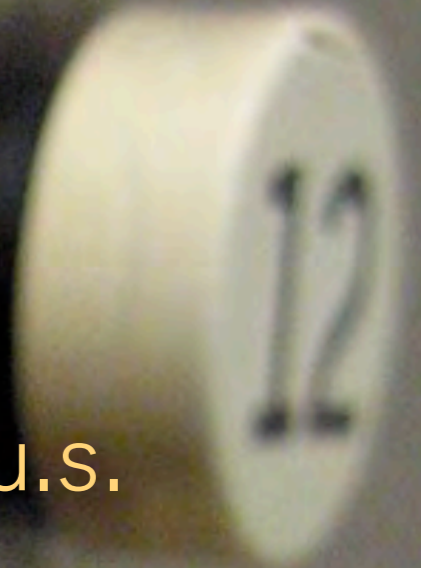

20 homes

efficient elevator controls can save enough to power



75 percent savings on
ENERGY

each saving **4** car emissions

\$ **6500** year



\$350 per year

COMMUNITY INVOLVEMENT

red lights indicate
poor performance

green lights indicate
better performance



**GALLE FACE HOTEL
ADMIRE
YOUR DECISION
NOT TO SMOKE**
C.G.

Its good for you
**PLEASE
WALK DOWN**
2 flights only



TO PREVENT
MOSQUITOES
ENTERING THE ROOM
PLEASE DO NOT OPEN
THE WINDOWS.

If you reuse the towels,
a donation will be made to
a nonprofit environmental
organization.

A donation has already
been made to a nonprofit
environmental organization,
since we trusted you'd
reuse your towels.

45%
more

HERD EFFECT PERSONALIZED

Many prior hotel guests have been eco-friendly by reusing their towels.

Most of the guests in this room reuse their towels.

33%
more

This complex is designed for the education of future hospitality managers. Many of the staff you come in contact with and who serve you, in all areas of the hotel and conference center, are students learning the many components of the hospitality industry. We look forward to your visit, and welcome you as our guests.



5000 watts



gear & flywheel assembly



rotating magnetic wheel



fixed wire coil wheel



glass protective enclosure

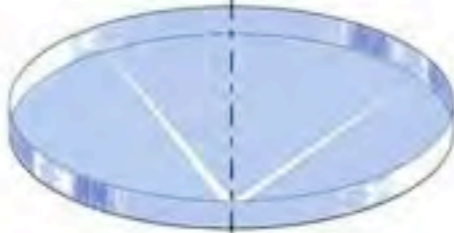

door panels & structure

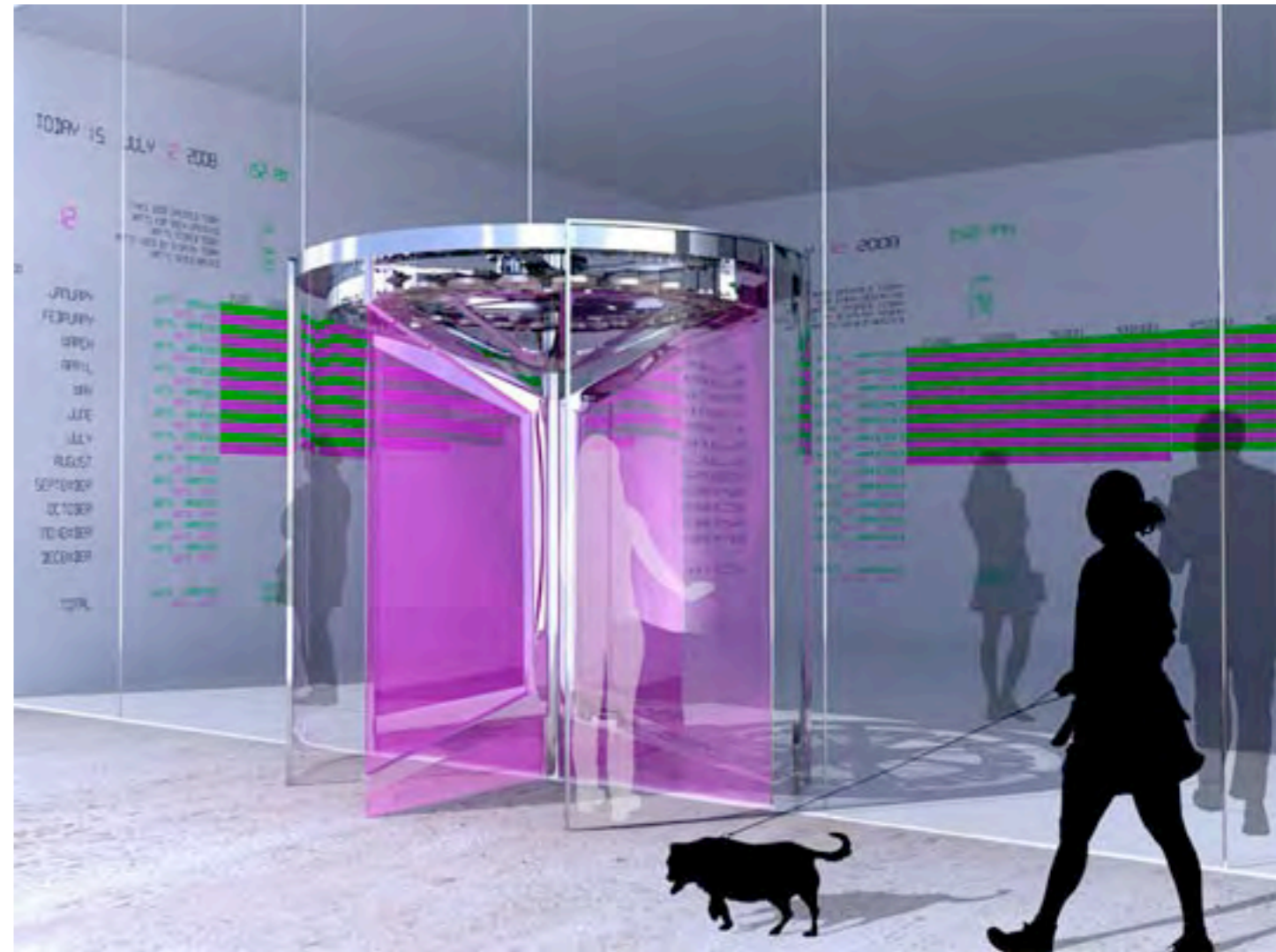
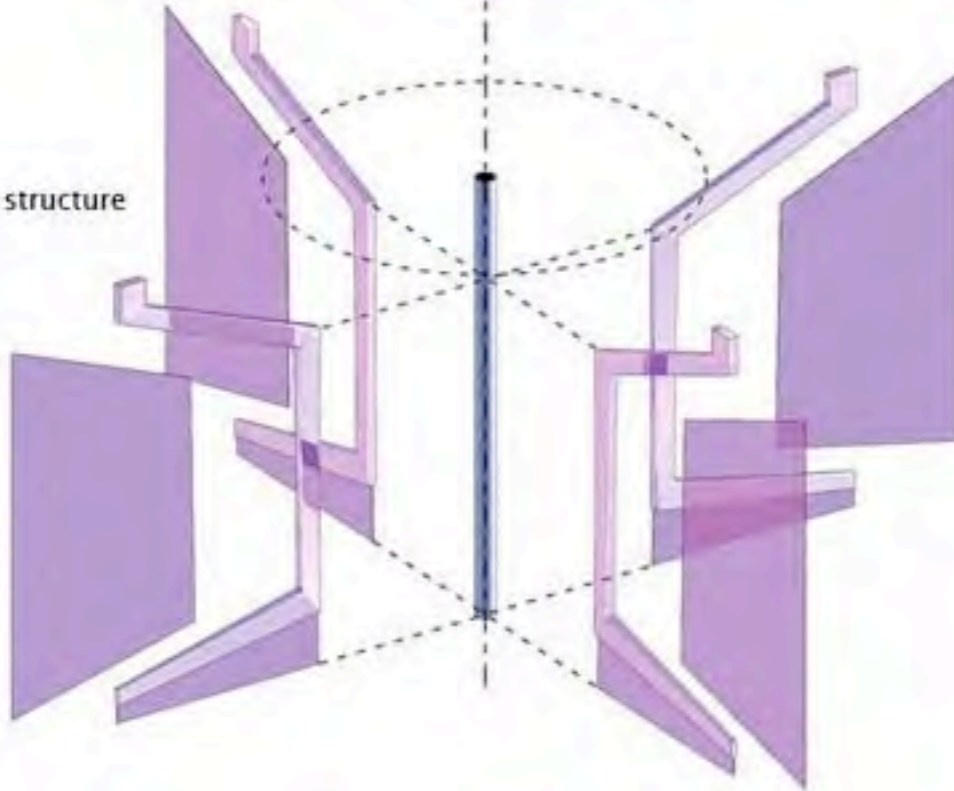



BACK OF HOUSE

200%

TOTAL ENERGY SAVINGS

185° > 150°

lower temperature



31%
of energy use

30%

DUCT LEAKAGE

CHANGE YOUR FILTERS

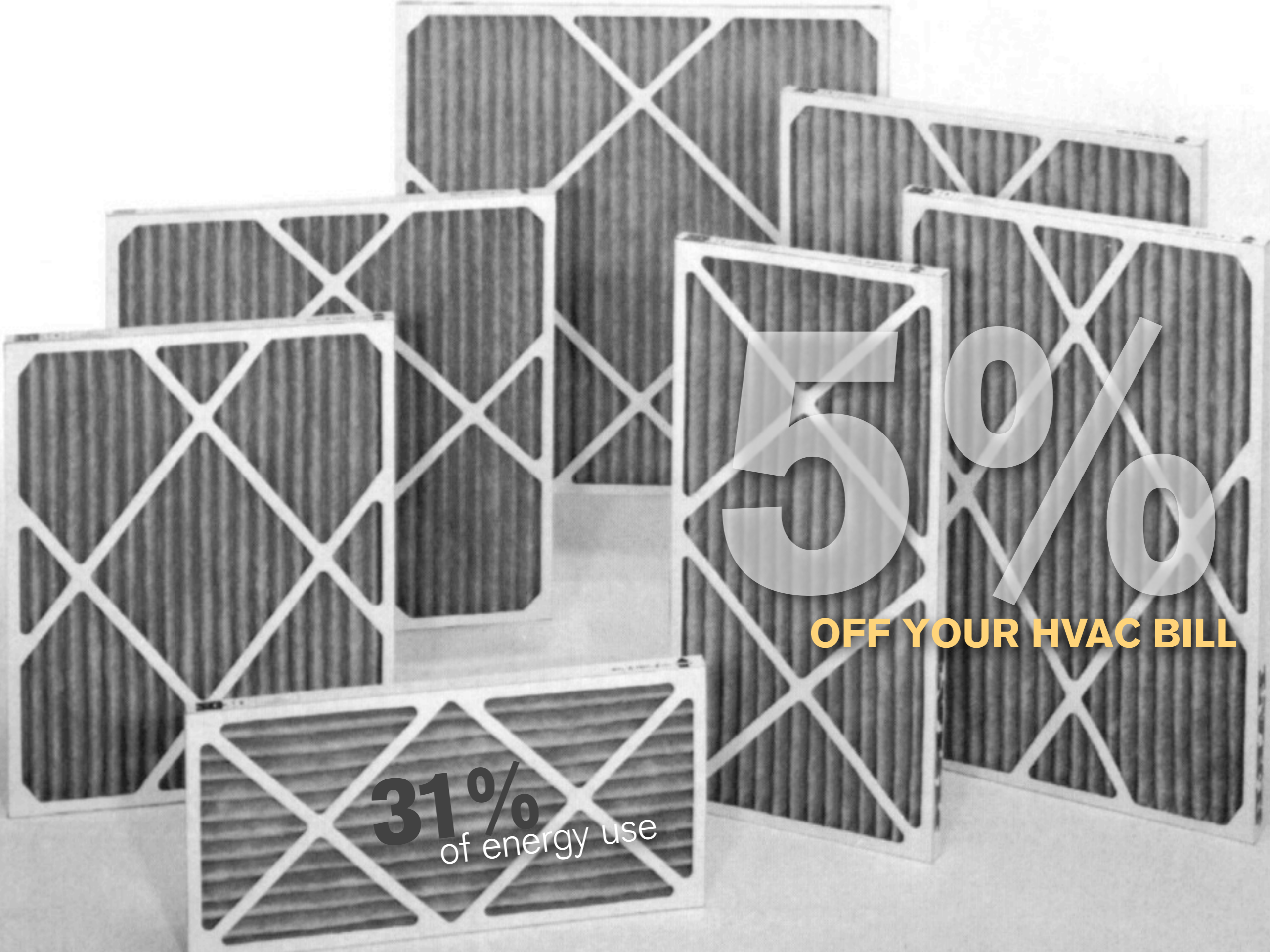

50%

OFF YOUR HVAC BILL

31%
of energy use

SOURCE: California Energy Commission



LANDSCAPE



SOLAR POOL HEATING

75%

ENERGY SAVINGS

17%
of energy use

DO NOT REVERSE
OR OVERTAKE
HERE



zipcar.com

zipcar.com



COOL ROOF SAVINGS

70



40° C

cooler

COOL ROOF SAVINGS

\$4,000,000,000

by 2015

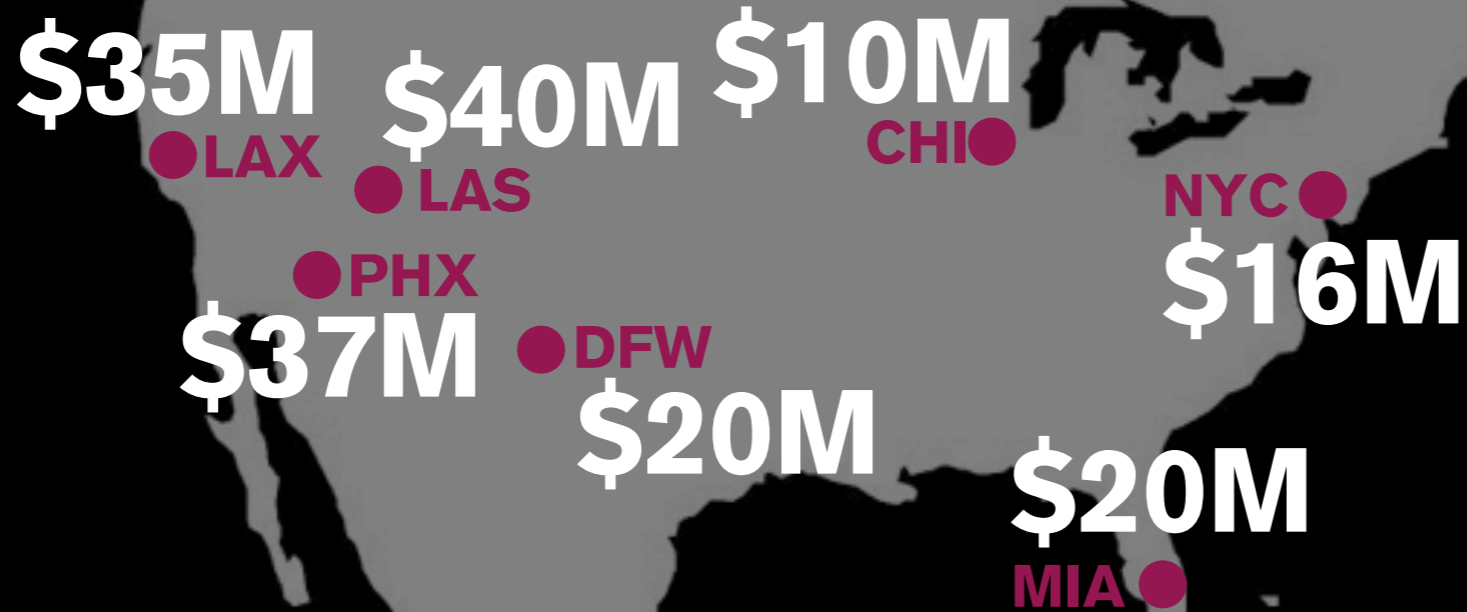

GREEN ROOF SAVINGS

40%
energy savings



Fairmont
HOTELS & RESORTS

fairmont.com



WATER CATCHMENT

$$1000_{sf} = 632_{gal/in}$$

$$9285_{sf} = 5868_{gal/in}$$

65,000_{sf} building / 7 floors
= 9285.7_{sf} roof area

$$= \underline{21} \text{ inches per year}$$

$$\times \underline{5,868} \text{ gallons} = \underline{123,240} \text{ gallons/year}$$

DRIP IRRIGATION

WATER SAVINGS

60%

POROUS PAVING

20°

LOWER TEMPERATURE

53 Old Bedford Rd, MA 02790

Borden St

green roof

cool roof

solar panels
shade south

native
plants
w/drip

porous paving
shade trees

water catchment

total energy savings
80%

69 m

© 2009 Tele Atlas

elev 43 m

Jul 29, 2007

Eye alt 278

3.49° N 71°06'44.99" W

Google



®
™

COFFEE

BY MICHAEL O'NEILL
— IN THE BEGINNING —

IT ALL STARTED WITH A CUP OF COFFEE





**Free Wi-Fi
for everyone.**
Now at Starbucks.





muffin top



interesting person



SOURCE: Bernie Hou

SOURCE: Starbucks, as of September 2009



locations

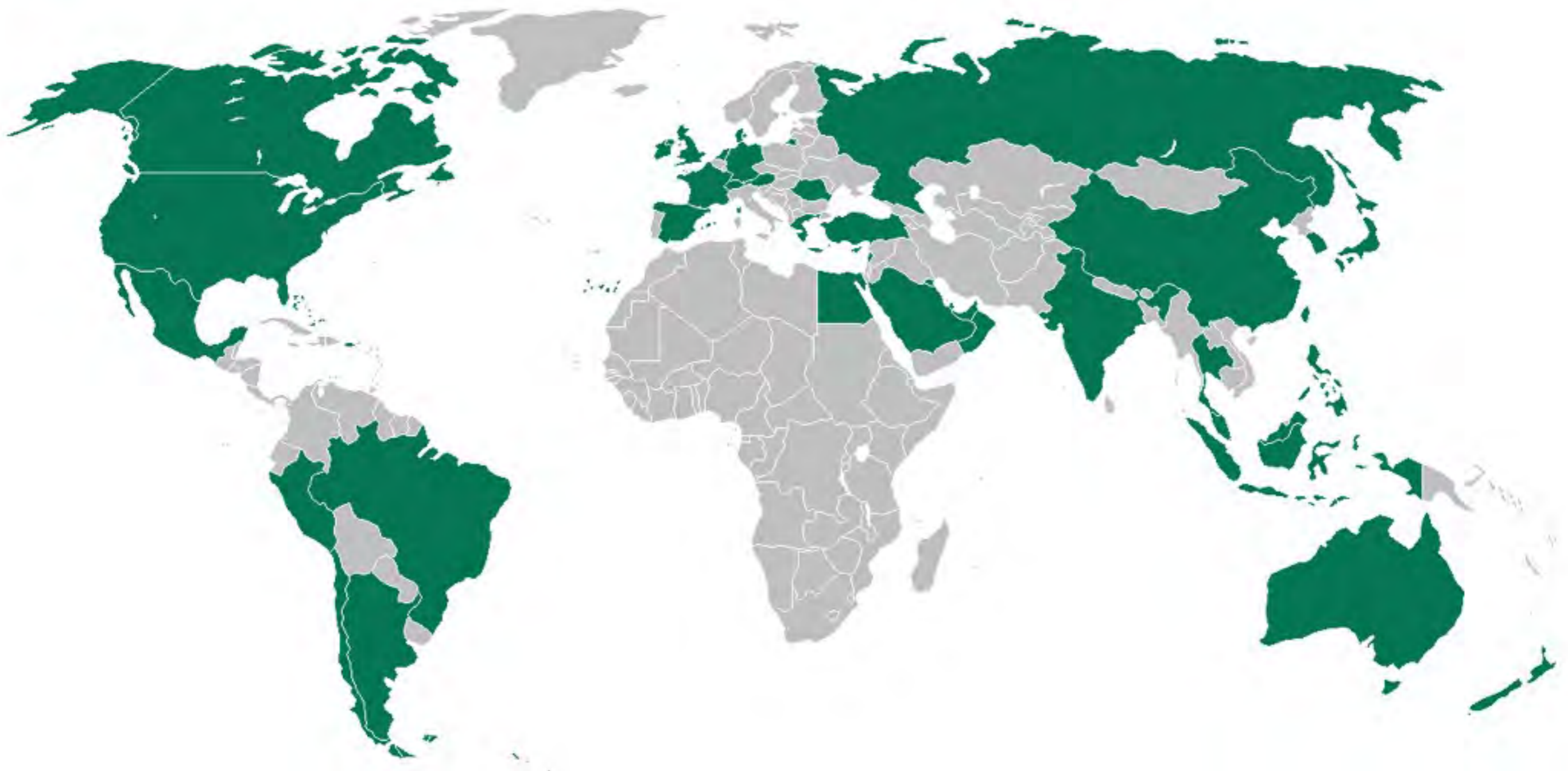

>16,000 LOCATIONS
50 COUNTRIES

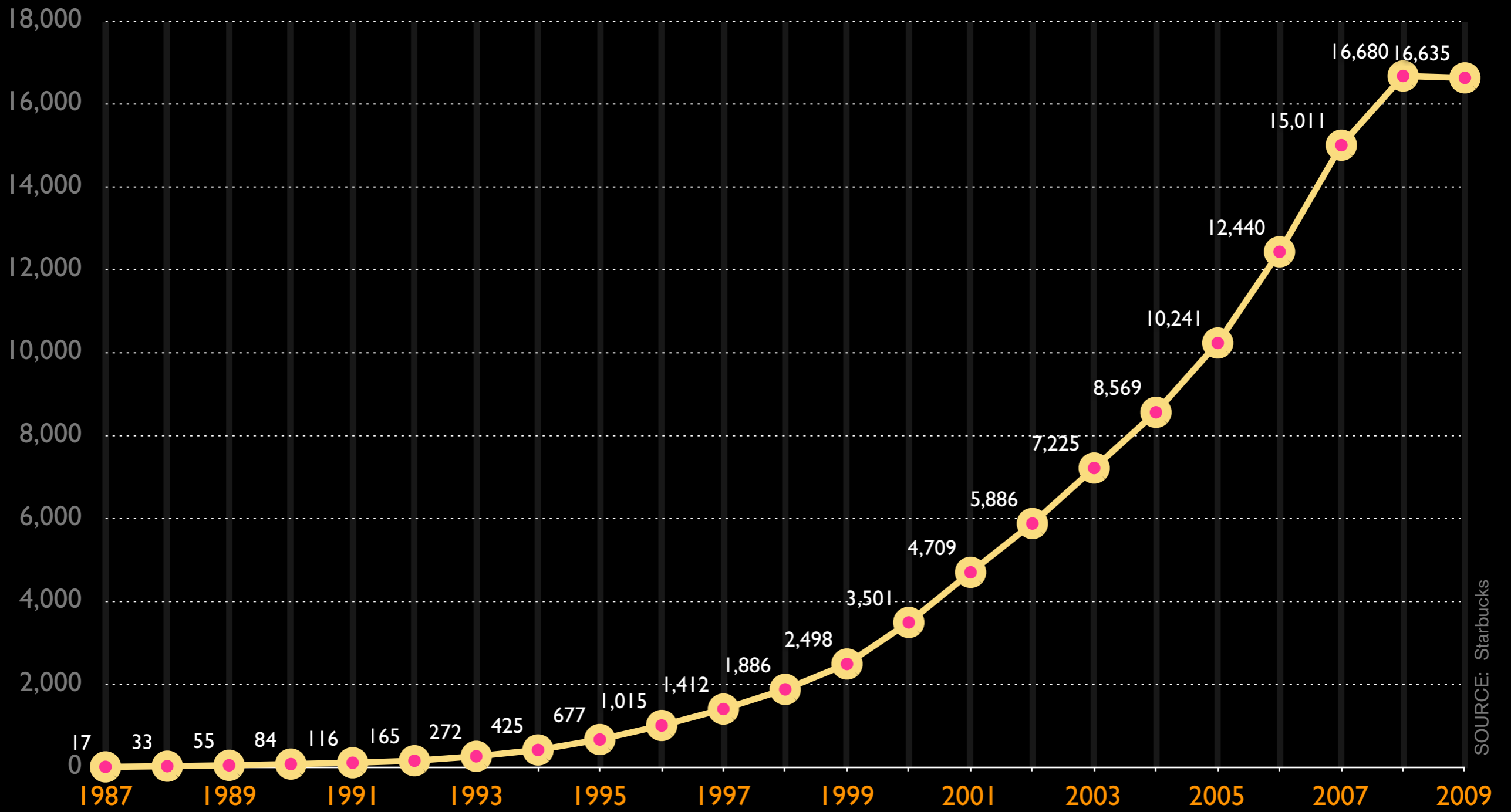

SOURCE: Starbucks

>16,000 LOCATIONS
50 COUNTRIES

US STARBUCKS LOCATIONS



WALMARTS PER CAPITA

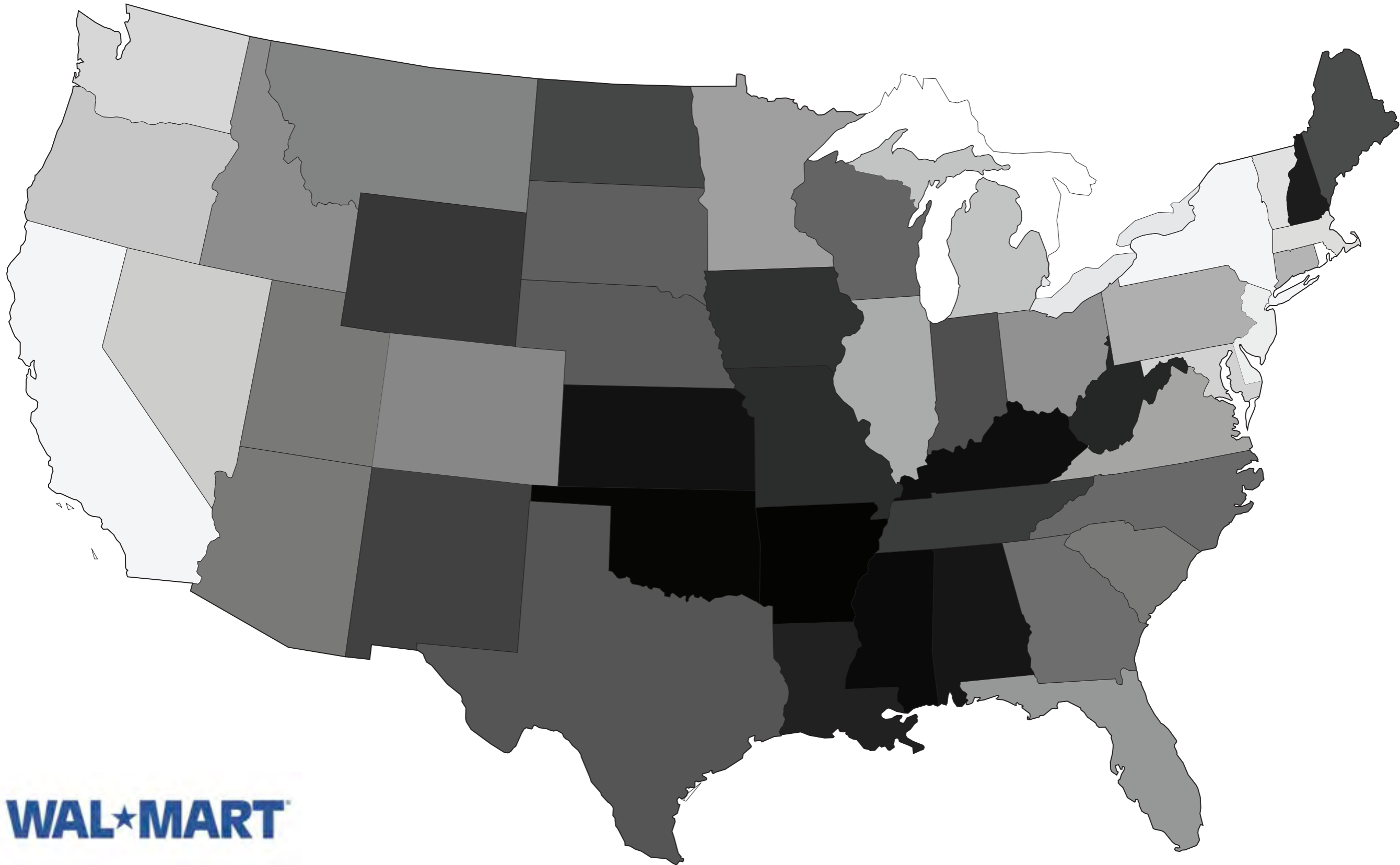

STARBUCKS PER CAPITA

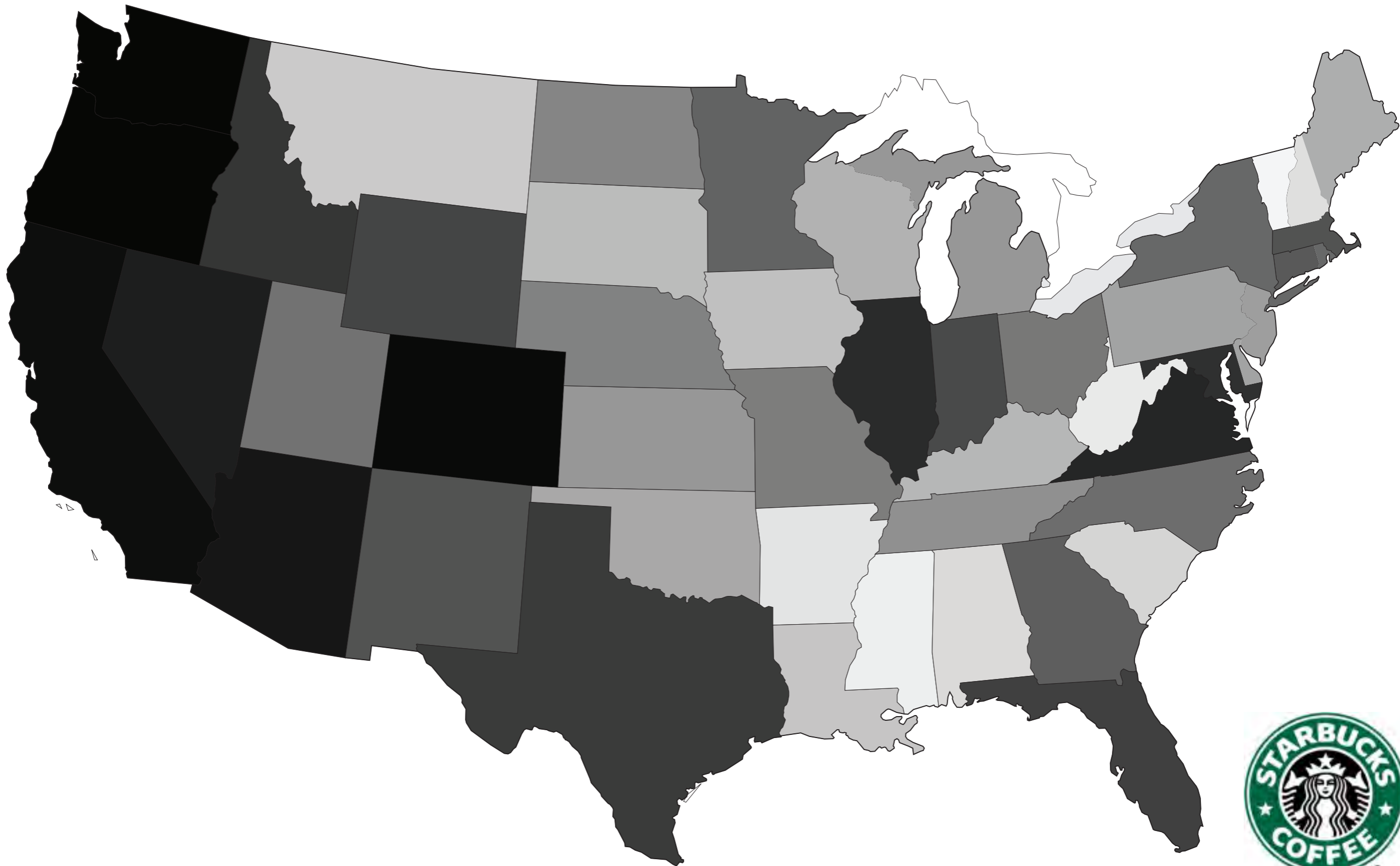

LEED CERTIFIED BUILDINGS



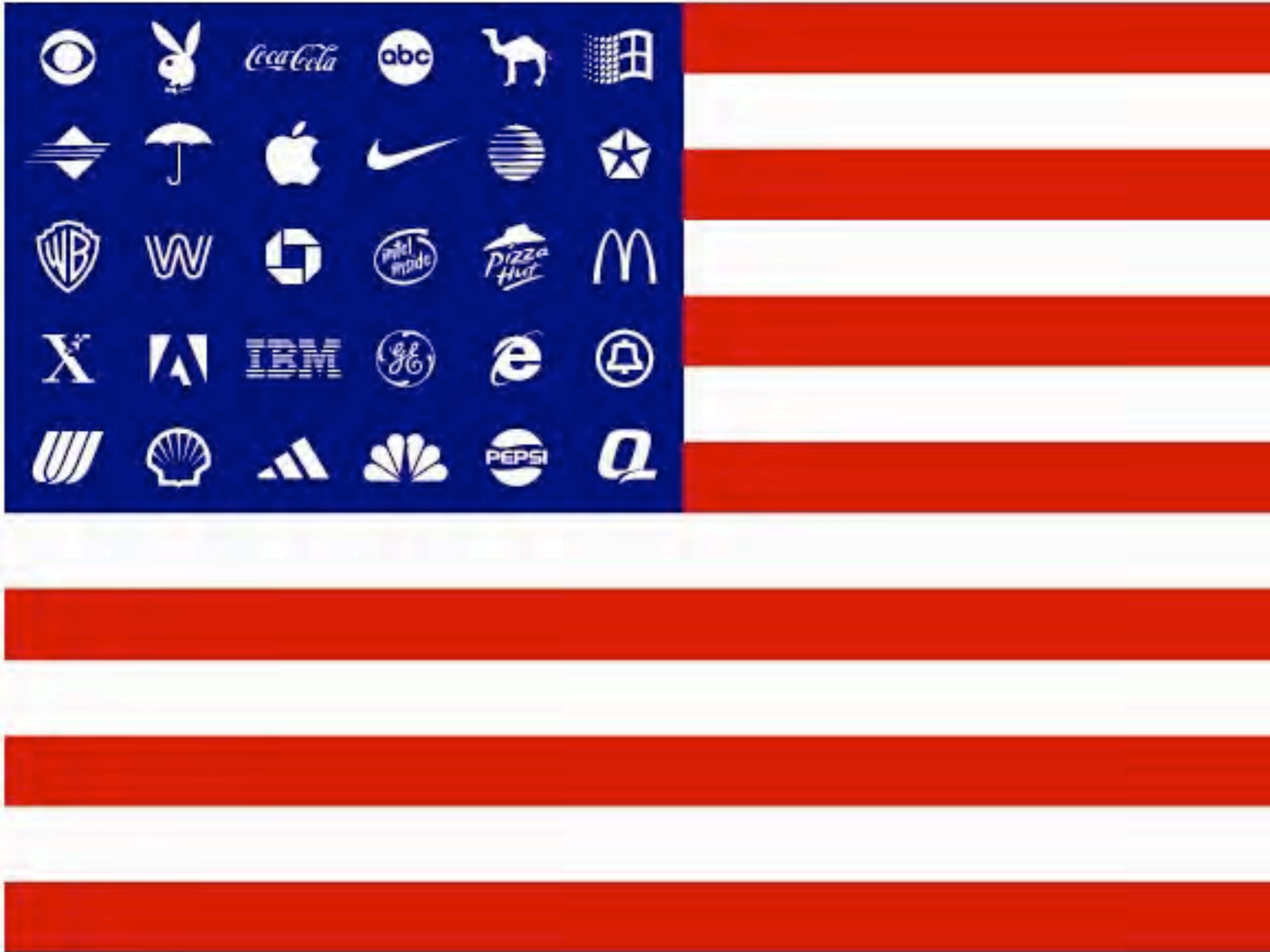

Coca-Cola

abc



IBM



PEPSI



COMMAND LINE

Language distillation and translation

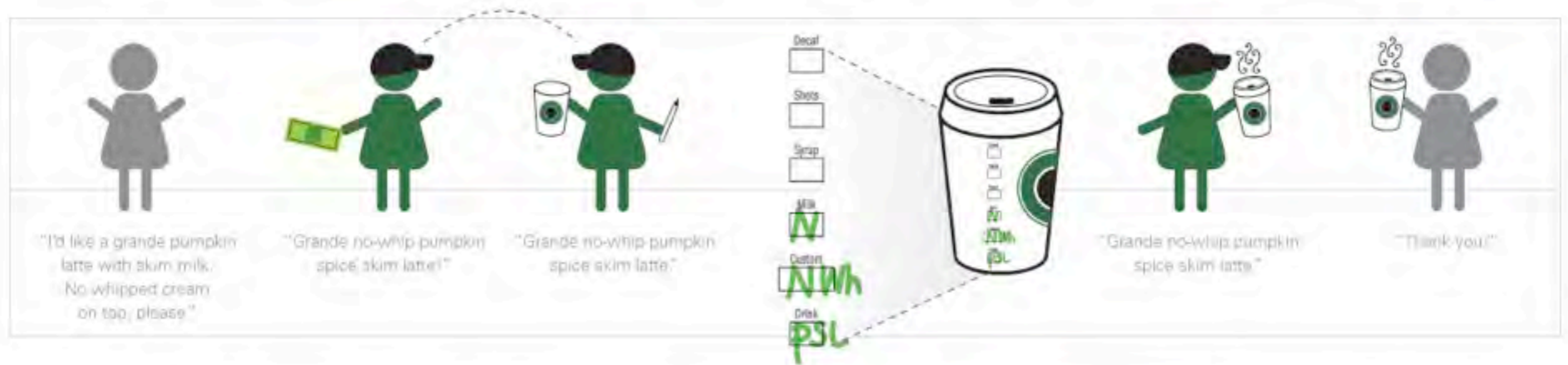

Long Form Language

(Understood by customer & cashier)

Short Form Language

(Understood by all)

Short Form Notation

(Understood by barista)

Short Form Language

(Understood by all)

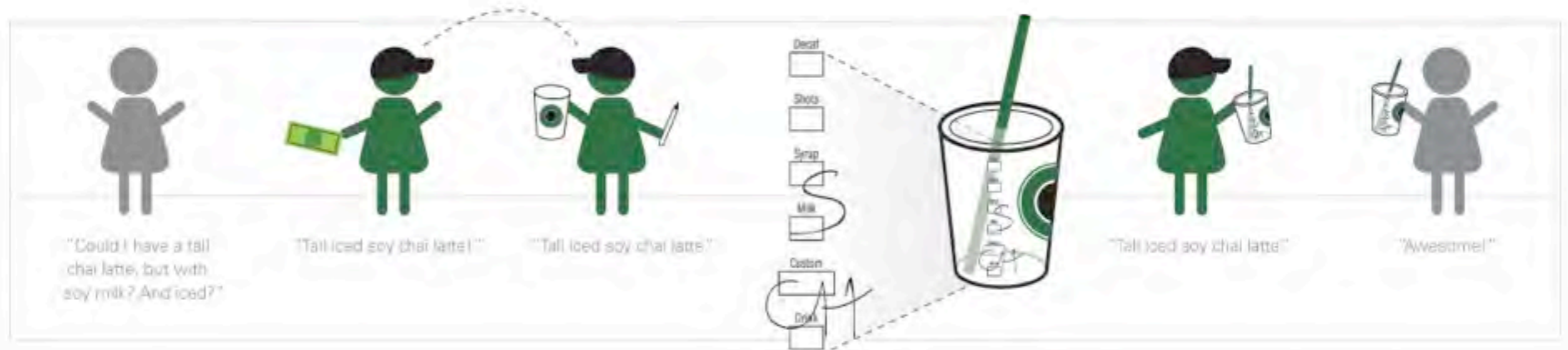

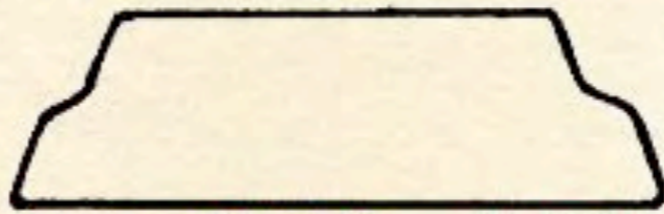

TALL ^{2 SH}LOTS

NONFAT

WET

Cappuccino

"My Starbucks" *M. Knight Jr...*





happiness

COFFEE CULTURE



Careful, the beverage you're about to enjoy is extremely hot.

11
time
WINNER



FORTUNE MAGAZINE
**100 Best Companies
To Work For**



ADDITIONAL AWARDS

10 Most Admired Companies

Best Ethical Score

Top 50 CSR



spends more on

HEALTH CARE

than

COFFEE BEANS

largest buyer of

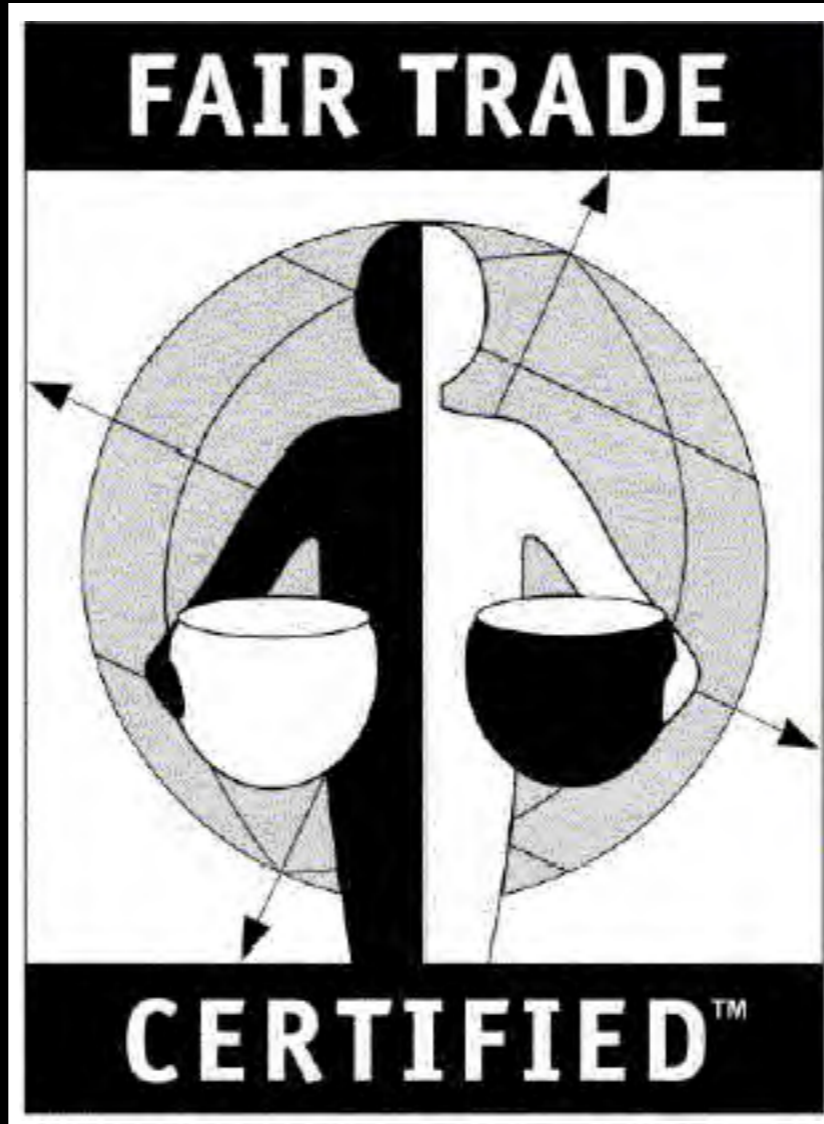

CERTIFIEDTM

**WHAT
IF WE ALL
CARED
ENOUGH
TO VOTE**



hen Recycle



a model company



Life happens over coffee

ecodilemma





produces

2,300,000,000 cups/yr

ANATOMY OF A CUP

Paper cups provide a convenient way to serve Starbucks hot beverages, but they also result in some environmental impacts.











globally throw away
58,000,000,000,000 cups/yr

10 of The Worst and Most Fat-Filled STARBUCKS BEVERAGES

STARBUCKS BEVERAGE

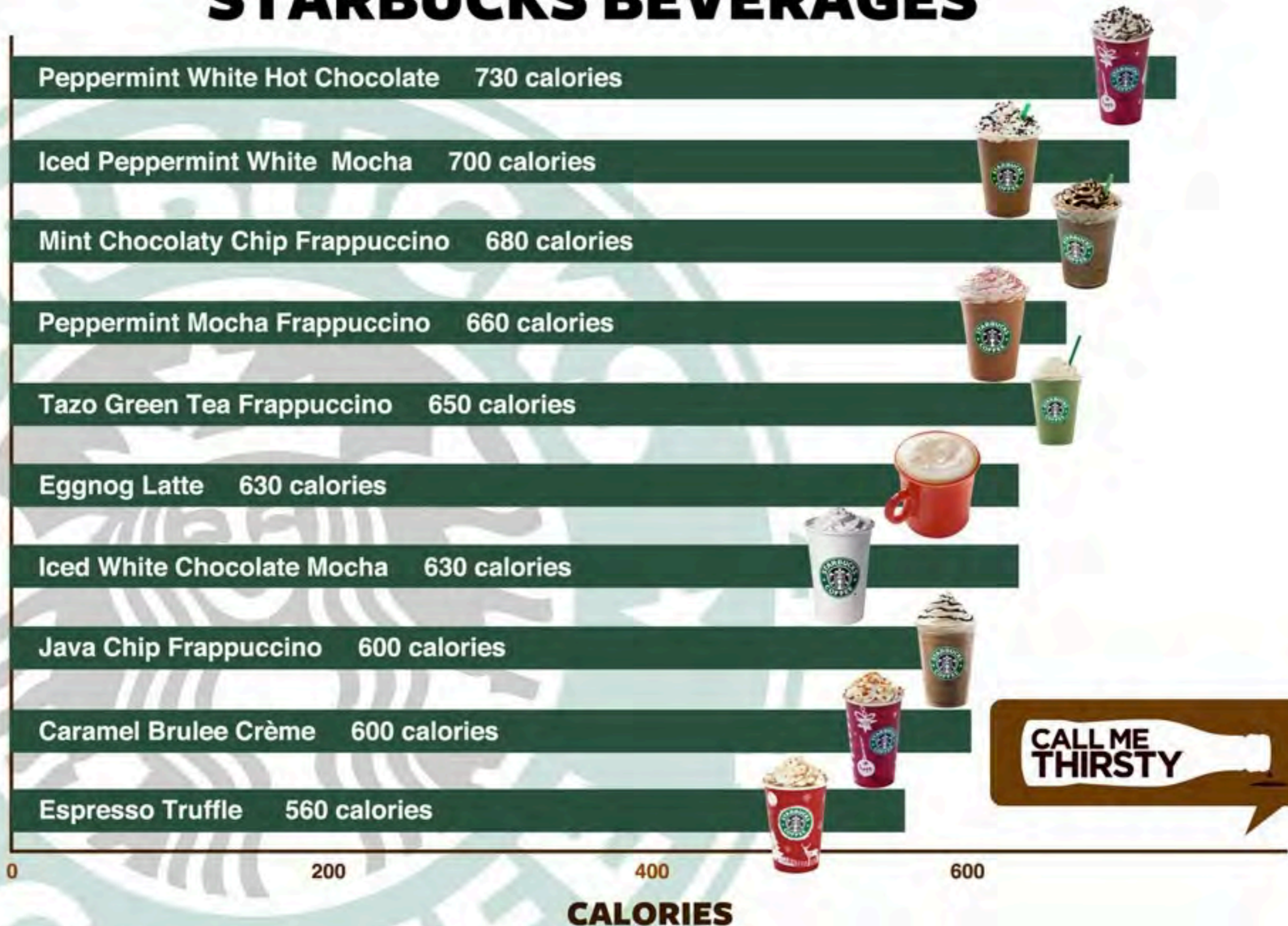

CALL ME THIRSTY



sourced from

13 countries





PUTS

LOCALLY OWNED

CAFES

OUT OF BUSINESS

No STARBUCKS
ban corporate coffee



VIP
[Illegible graffiti]



makes me unhappy



SUGGESTIONS

a better cup



SOLO  **?**

100% recycled paper
Corn-based plastic coating
Biodegradable Lids
Soy inks



create
the market to

RECYCLE



make every store

local

10%





grow
HERBS



GRAVITY

Gallery & Coffeehouse.

explore

the differences

manage

local cafes

A large, white, three-dimensional sign for "Office DEPOT" is mounted on a red, slanted metal awning of a building. The sign is in a bold, sans-serif font. The background is a clear blue sky.

Office DEPOT

LOCAL STORE WITHIN A STORE

A large, orange, three-dimensional sign for "THE HOME DEPOT" is mounted on a light-colored wall. The sign is in a bold, sans-serif font. The background is a clear blue sky.

THE HOME DEPOT

SMALLER TO REDUCE BLIGHT

GROW THEIR OWN FOOD

A neon sign for "Applebee's" is illuminated. The sign features the word "Applebee's" in a stylized, cursive font, outlined in orange and filled with a yellow-to-orange gradient. The sign is set against a dark background and is framed by a bright green neon border. A red apple logo is visible above the sign.

Applebee's

- **disinfectant smell**
- **brightly lit**
- **no bathroom mirrors**
- **bolted furniture**



High Team score
Mac Chaswick & Telton



modern
**environmental
movement**

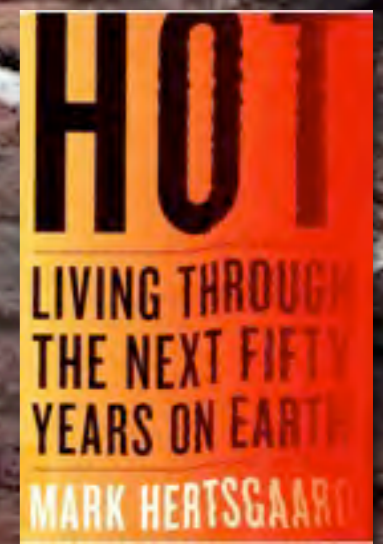
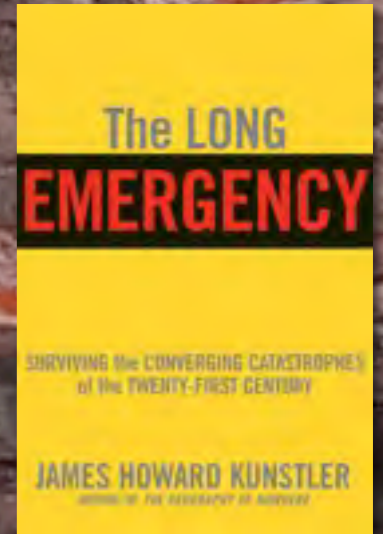
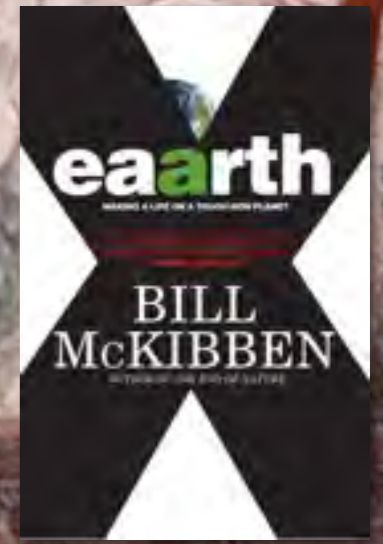

1970 - 2000 (30 years)

2000 - 2010 (10 years)

2010 - 2050 (40 years)

Guilt

Financial Payback

Dodo survival





this is a volunteer

they are volunteers





IF YOU DON'T PRESERVE NATURE BY USING LOW-WATTAGE BULBS, WHO WILL?

Today, with simple everyday actions, everyone can help preserve the environment and save power at the same time. For more information go to www.particuliers.edf.fr.





10% light
90% heat

90% light
10% heat

ATTENTION
EMPLOYEES
"MUST"
WASH HANDS
BEFORE RETURNING
TO WORK

ATTENTION
EMPLOYEES
"MUST"
WASH HANDS
BEFORE RETURNING
TO WORK





18%
don't wash their hands



 PLEASE RECYCLE

NO SMOKING

NO SPITTING





NO

Strangling
the
Dancers



SAVE WATER. SAVE LIFE.

URINATING PROHIBITED





change Your
Light Bulbs!

STILL: Emma Stone in Easy A



the amish



0 carbon footprint

no cars
no power tools
no stocks





(not amish)



(not amish)



(not amish)



(not amish)



(not amish)



(not amish)



DOUBLE DOWN SANDWICH

**IT'S
HERE!**

IDOT 3-03







(visionary)

Americans are 'profoundly bored'
by climate change

Institute for Public Policy Research

July 17, 2010



PHOTO: Hunter Freeman

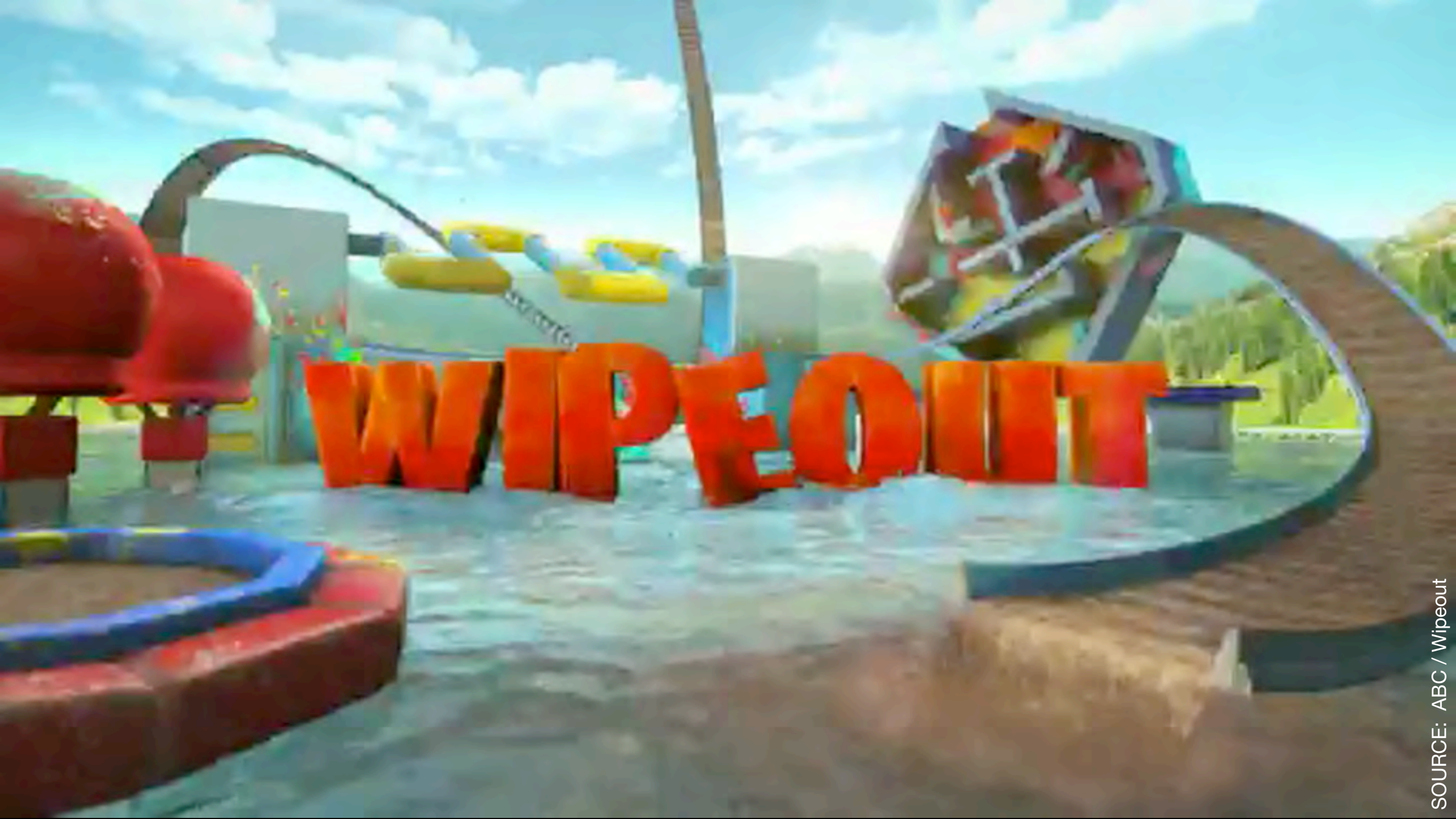





HIGHSCORE: 31470
SCORE: 0







Robert F. Kennedy Jr.
Walden University, July 2007

ocean oil

half | full = pessimist
empty = optimist
what ocean? = ceo of bp

MY CARBON FOOTPRINT
IS BIGGER THAN YOURS

dodo
SAPIENS



dodo
SAPIENS

50% ENERGY SAVINGS SUMMARY

metric tons of co2 saved

10,765,804

barrels of oil saved

25,036,752

coal fired power plants

2.5



metric tons of co2 saved

10,765,804

co2 cuts required by 2020

58,000,000

hotels alone

19%

co2 cuts required by 2050

1,450,000,000

8%

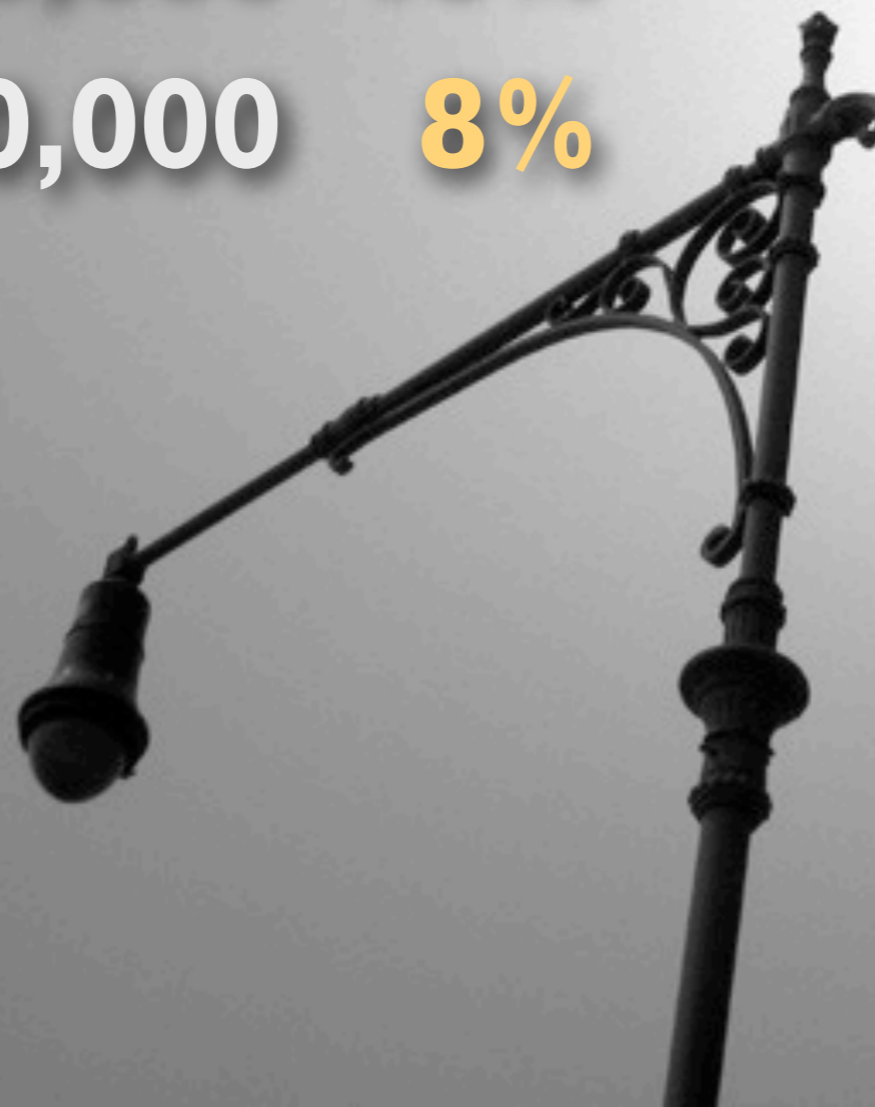

metric tons of co2 saved
10,765,804

barrels of oil saved
25,036,752

coal fired power plants
2.5





u.s. hotel
energy savings

=



Libya

+



U.A.E.

oil imports

barrels of oil saved

32,000,000





u.s. hotel
energy savings

=



Argentina

+



Egypt

oil imports

barrels of oil saved

23,200,000





u.s. hotel
energy savings

=



South Korea

+



Vietnam

oil imports

barrels of oil saved

28,285,000





u.s. hotel
energy savings

=



France
oil imports

barrels of oil saved

32,468,000





GLOBAL
WARMING



**CLIMATE CHANGE
IS A HOAX**

**SEA LEVELS ARE RISING BECAUSE
JESUS IS CRYING**

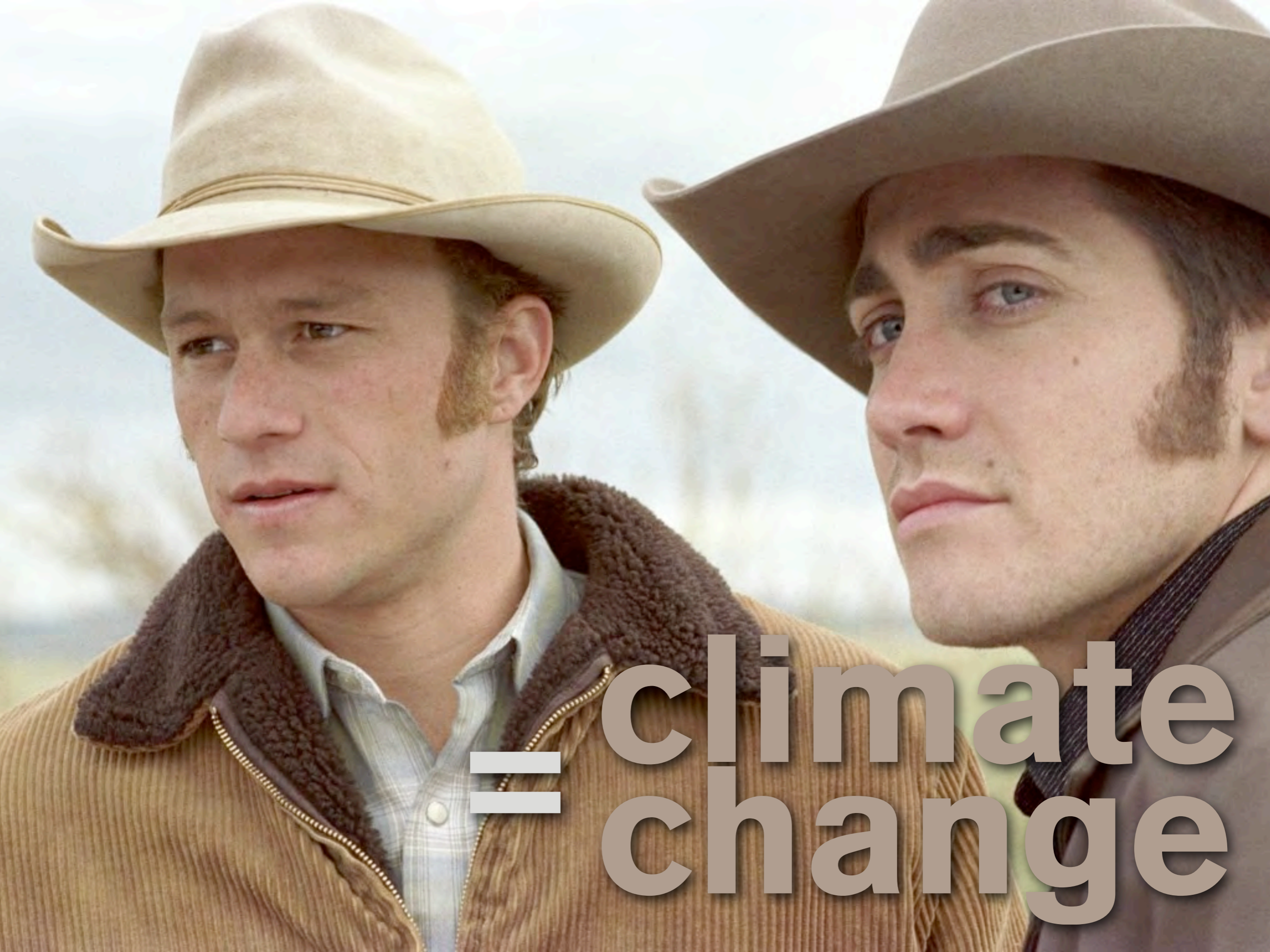

climate
change

Global Carbon Emissions

1751-2007

Fossil fuels from Colonial days through the Industrial Revolution

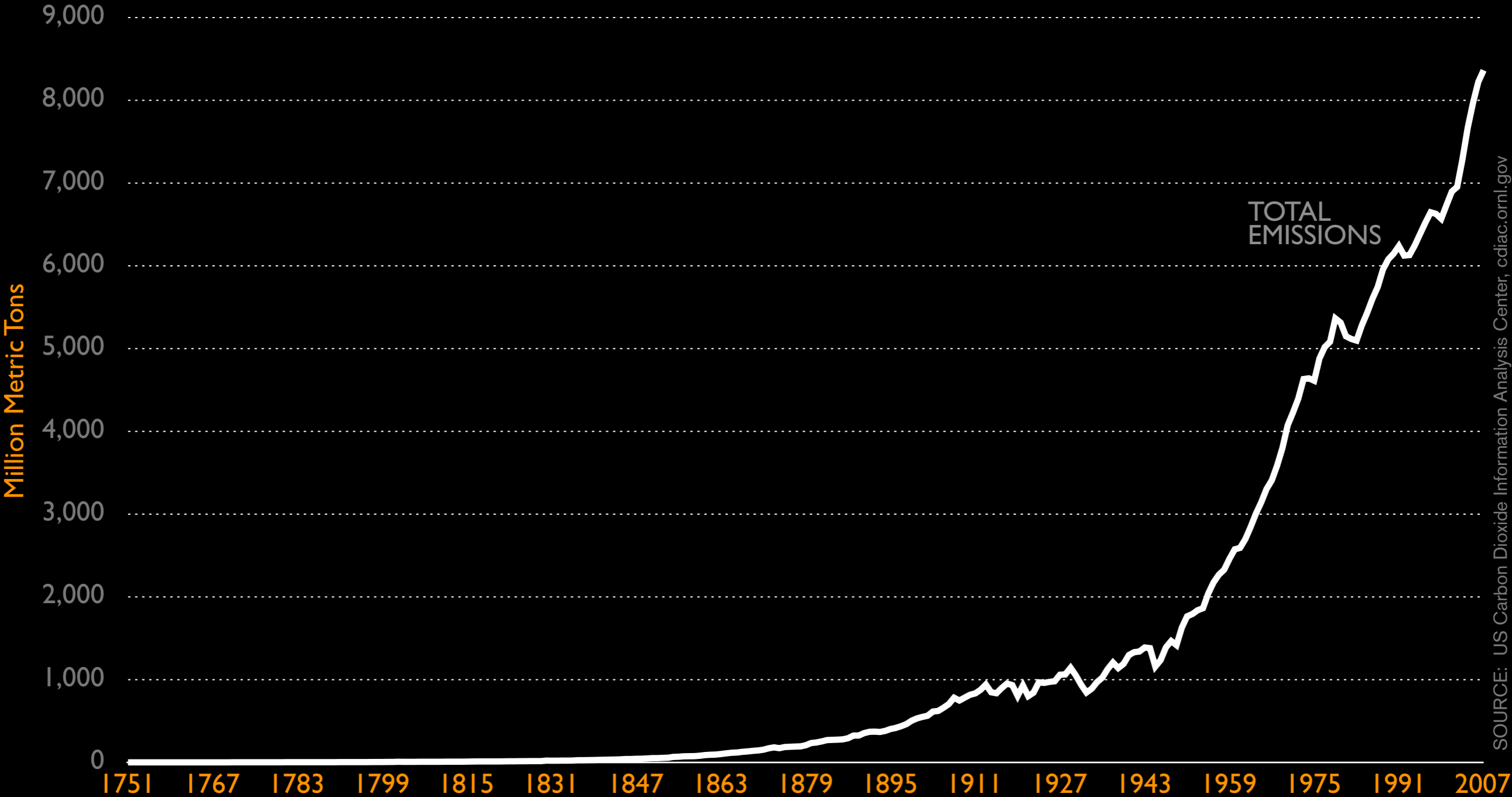

SOURCE: US Carbon Dioxide Information Analysis Center, cdiac.ornl.gov

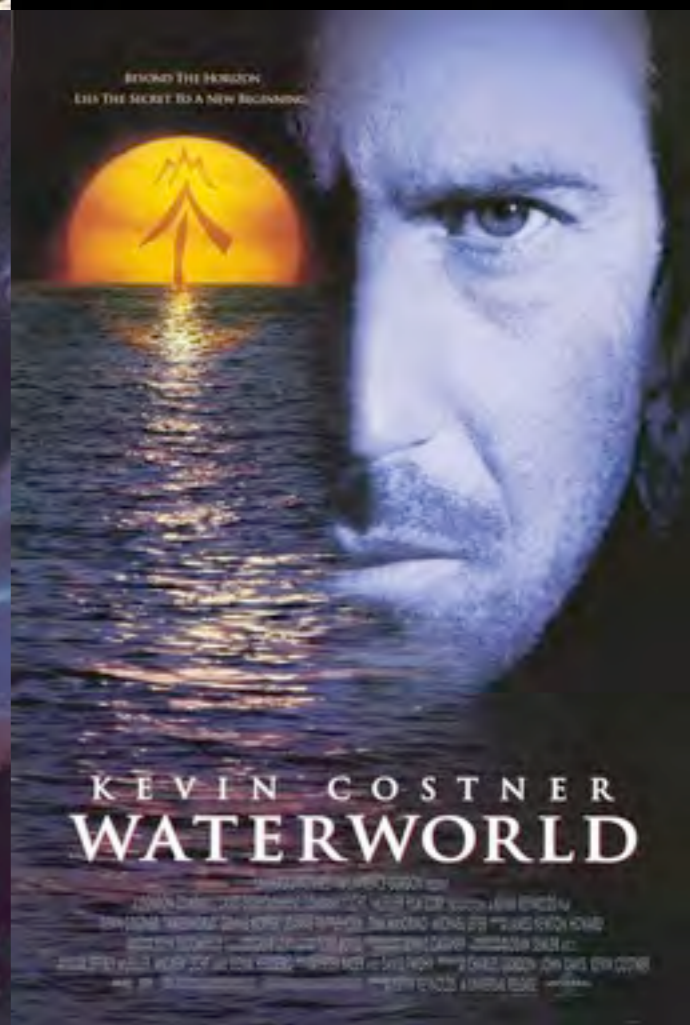
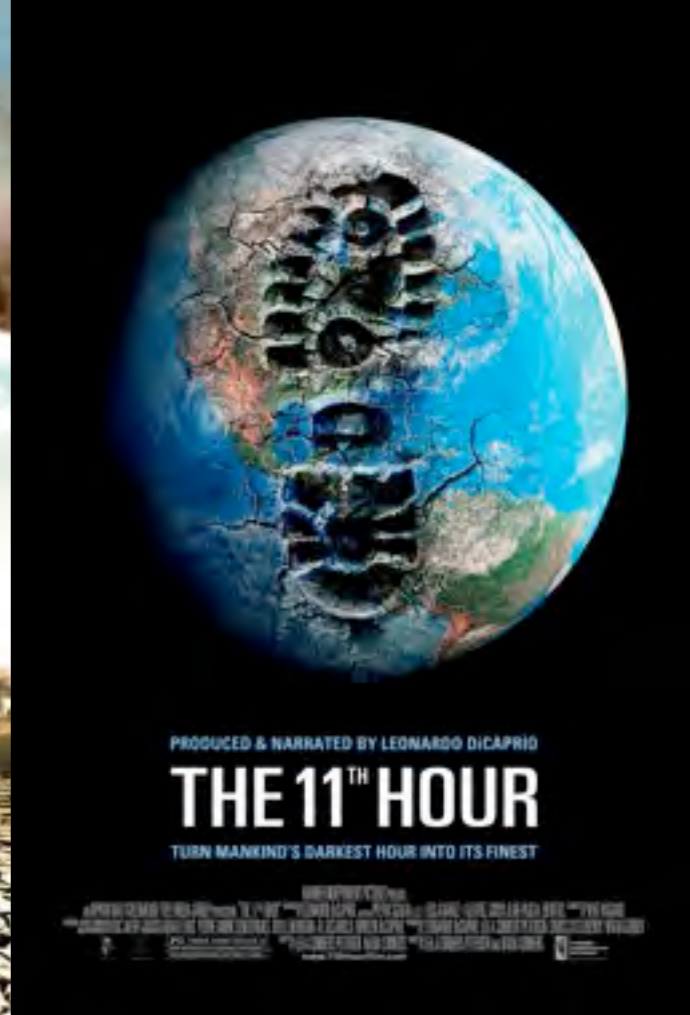



Belief in Global Warming

2006-2009

Despite the facts, belief in Man Made Climate Change is waning

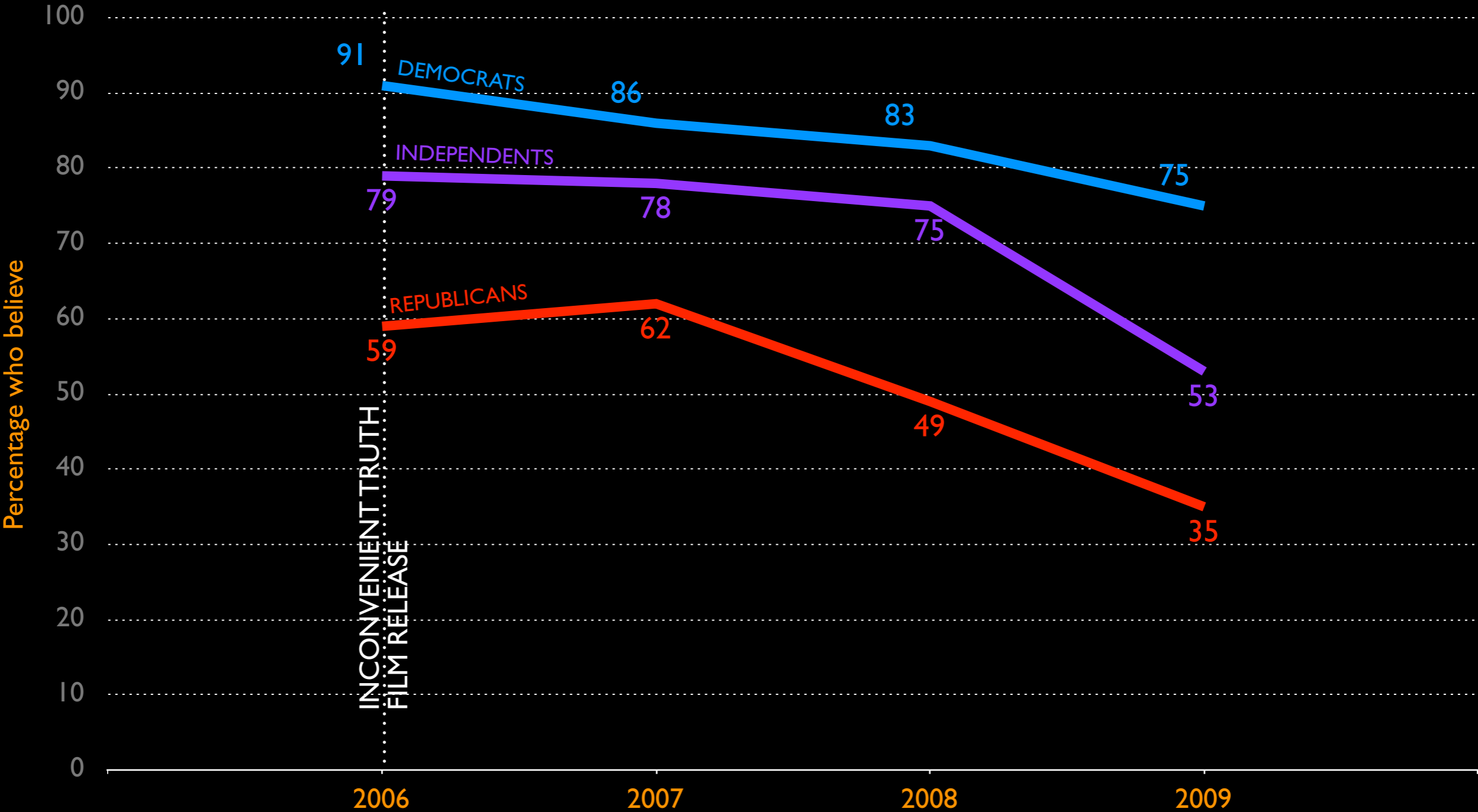

SOURCE: Pew Research Center

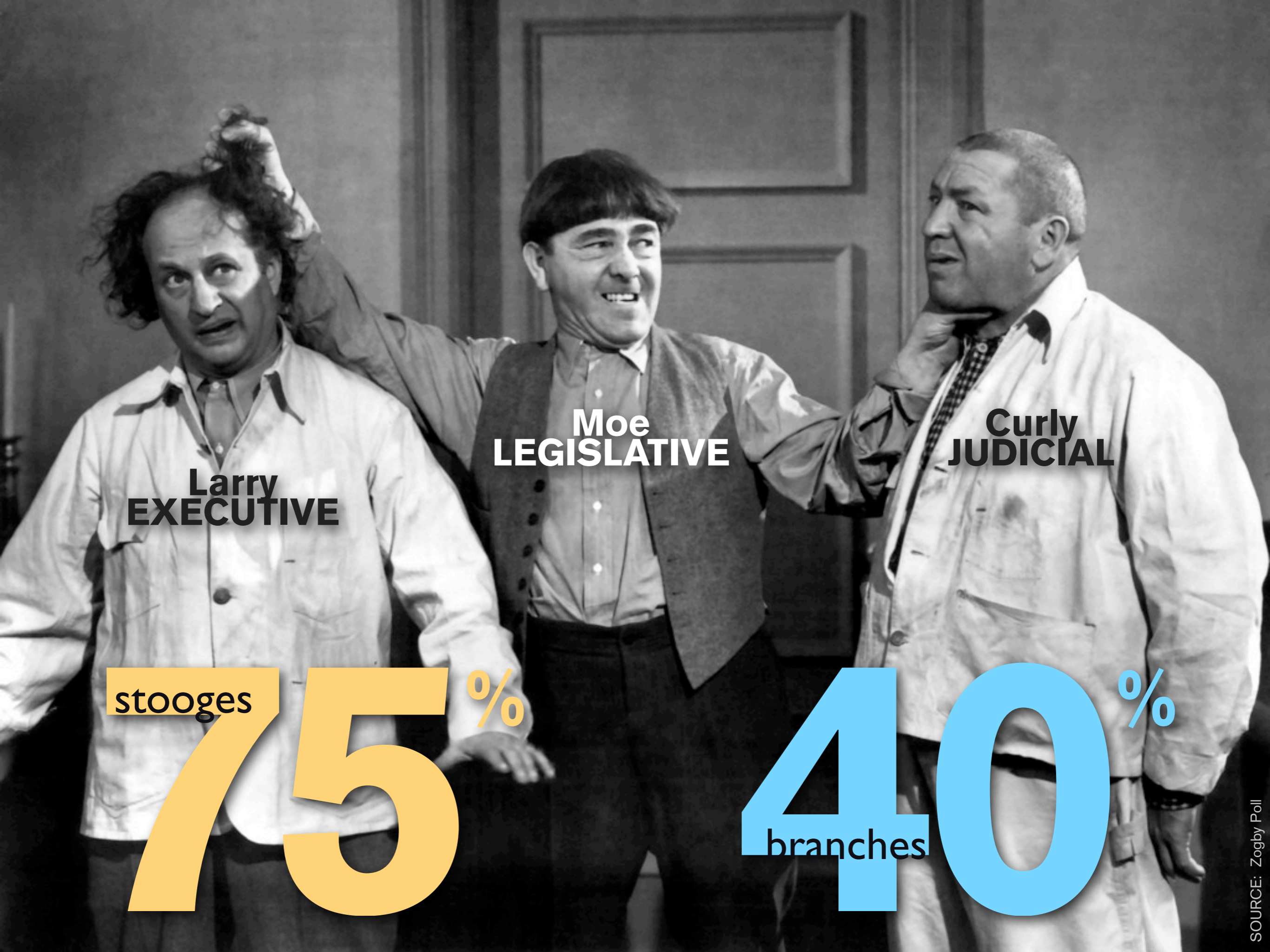

**Larry
EXECUTIVE**

**Moe
LEGISLATIVE**

**Curly
JUDICIAL**

stooges

75%

branches

40%



what

AMERICANS

believe...



EVOLUTION

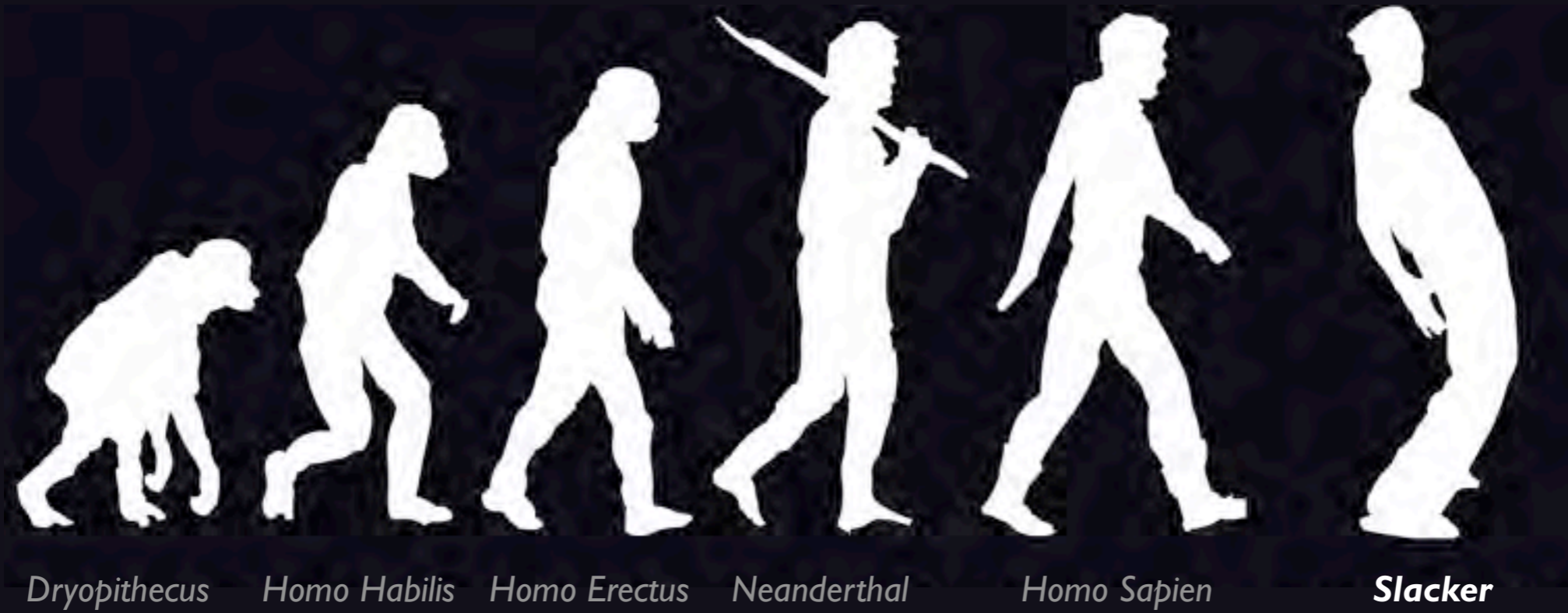

39%
believe

ENVIRONMENTALISTS DID IT

SABOTAGE

10%
believe



20
believe
%

NEVER THERE

11 %
believe



Bewitched

21

believe

%

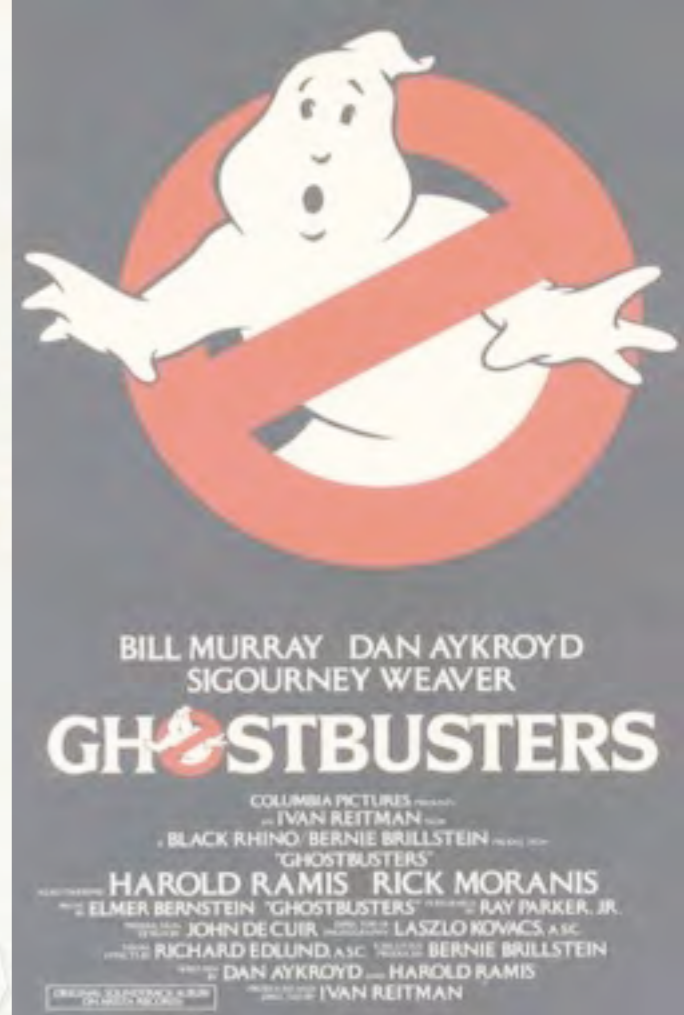
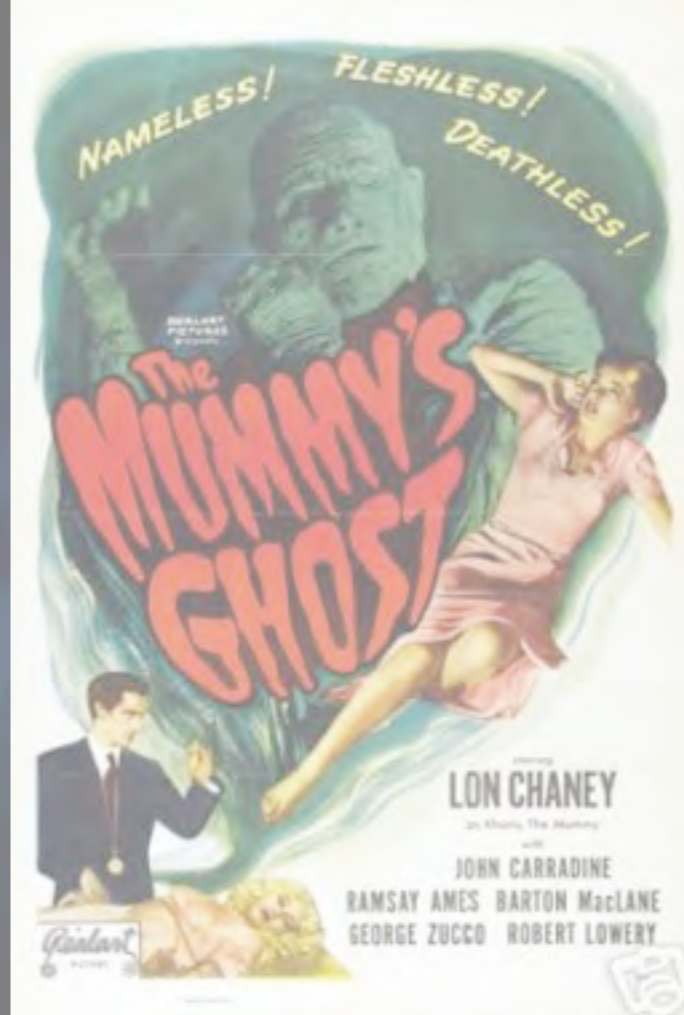

EXTRA-SENSORY PERCEPTION



41%
believe

SOURCE: Gallup Poll

REINCARNATION



20% believe

DEATH PANELS



322

41%
believe

ALIENS



80%
believe

UFO



32% believe

ELVIS LIVES!



6%
believe



94% can't believe

WHO CARES?



as American as...



Blissful Ignorance

the new national pastime





MORONS



I DON'T BELIEVE IN
GLOBAL WARMING

Sea Ice 2008

RIGHT

(& the scientists are wrong)

EITHER

WRONG

(& the scientists are right)

NEITHER



Global warming



Loading...

Please don't wait.

take control of our
ENERGY SUPPLY

out of the hands of

**OIL & COAL
COMPANIES**

and we must

ACT NOW

to prevent

CATASTROPHE



“climidia”

what's next:

5

action steps

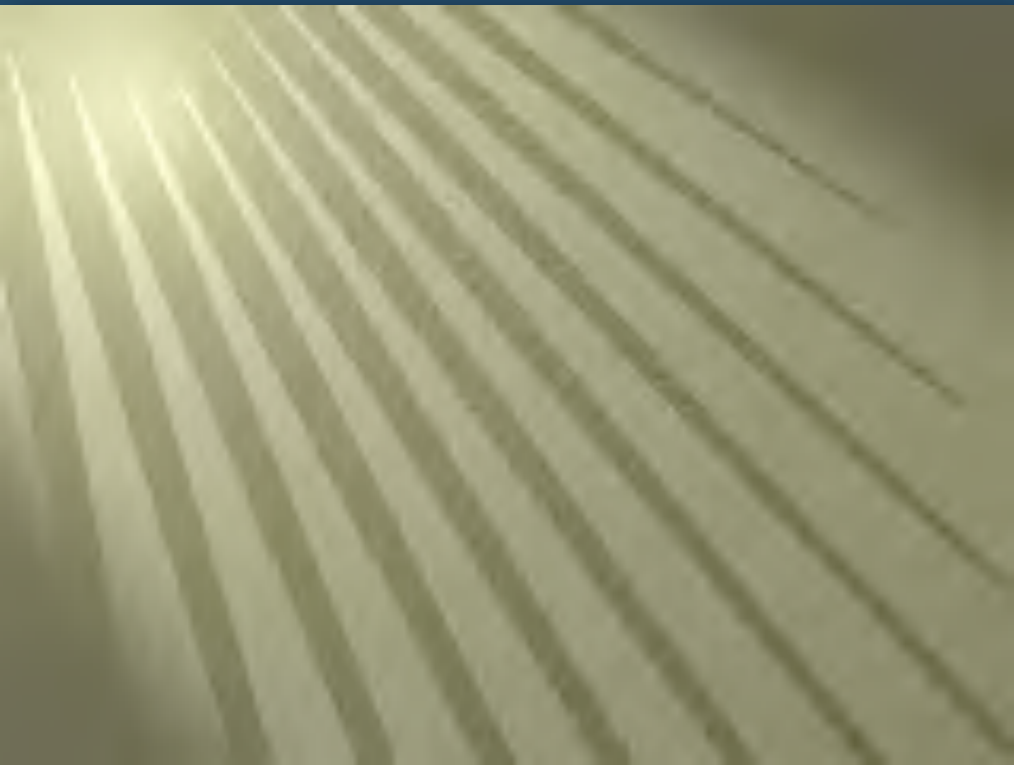

1

**get a free waste
assessment from
atlanticeenergy.net**

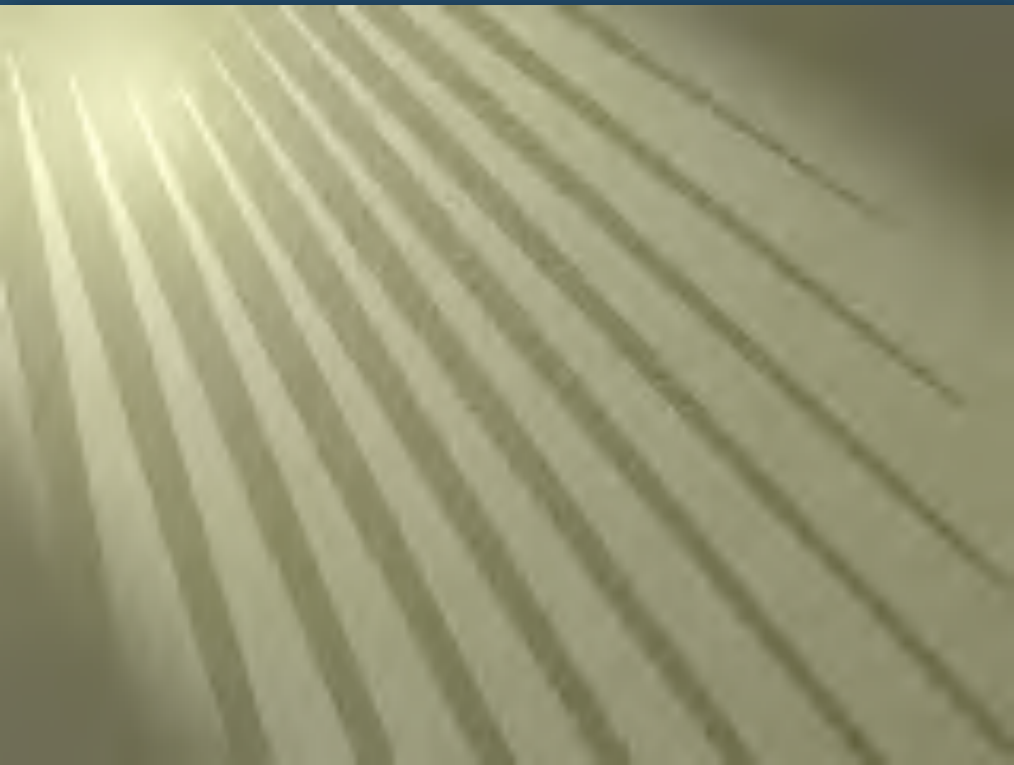

2 put capital people
in same room
as operations

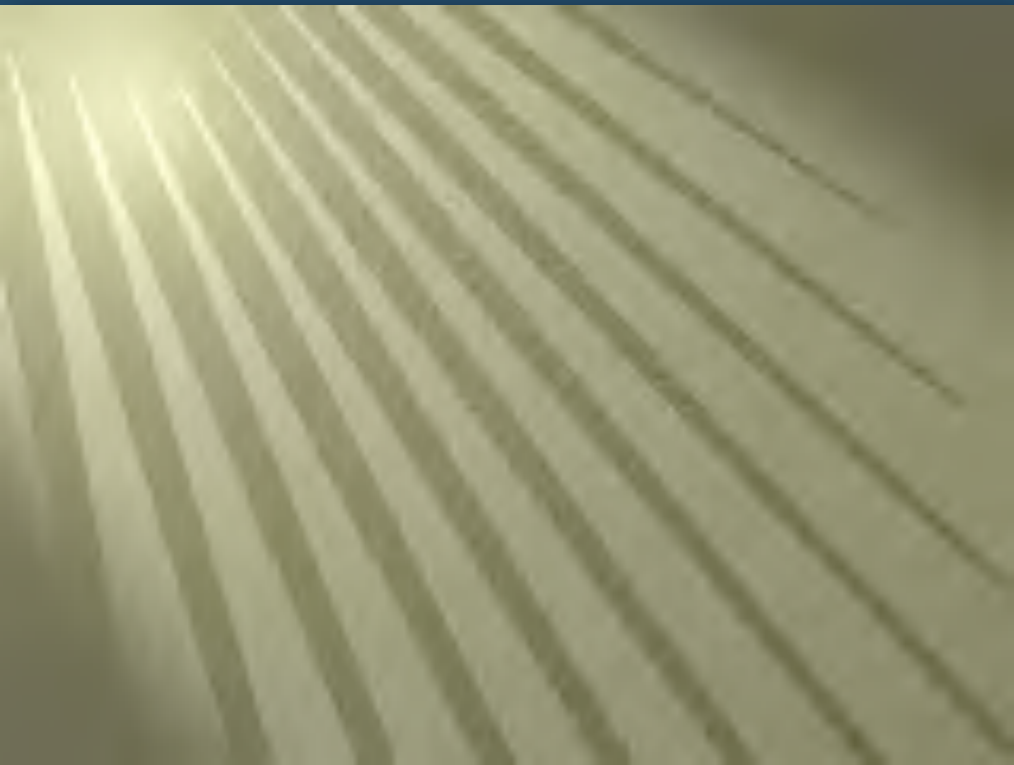

3 follow the money
to uncover the
easiest savings

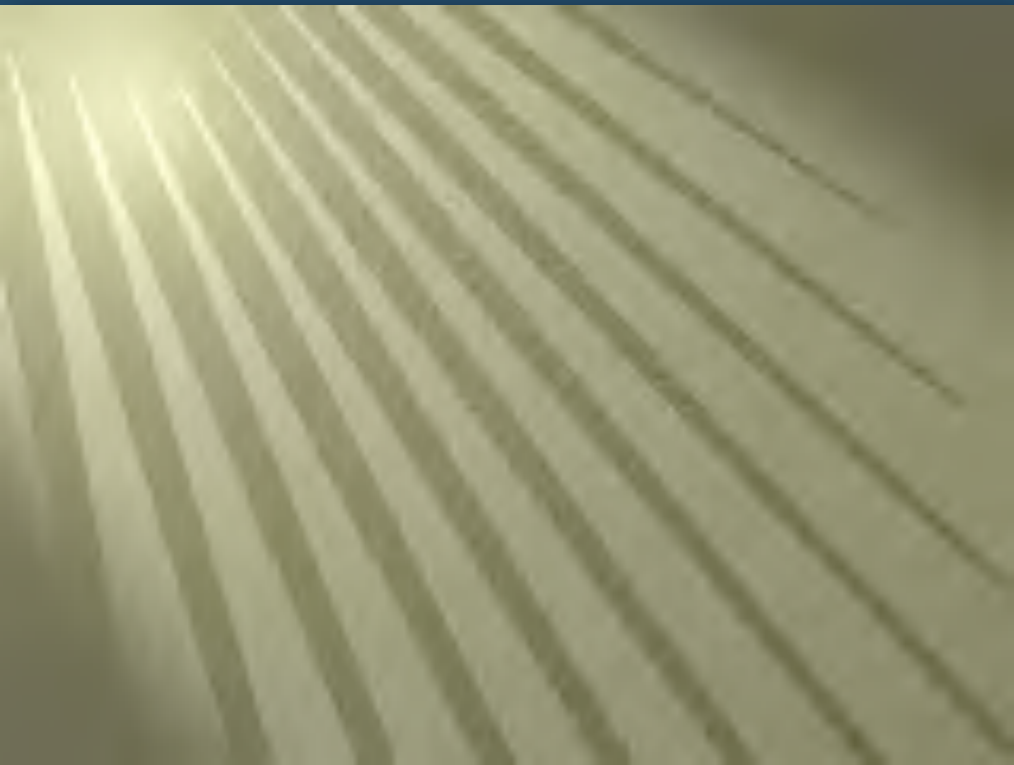

4 measure everything measurable

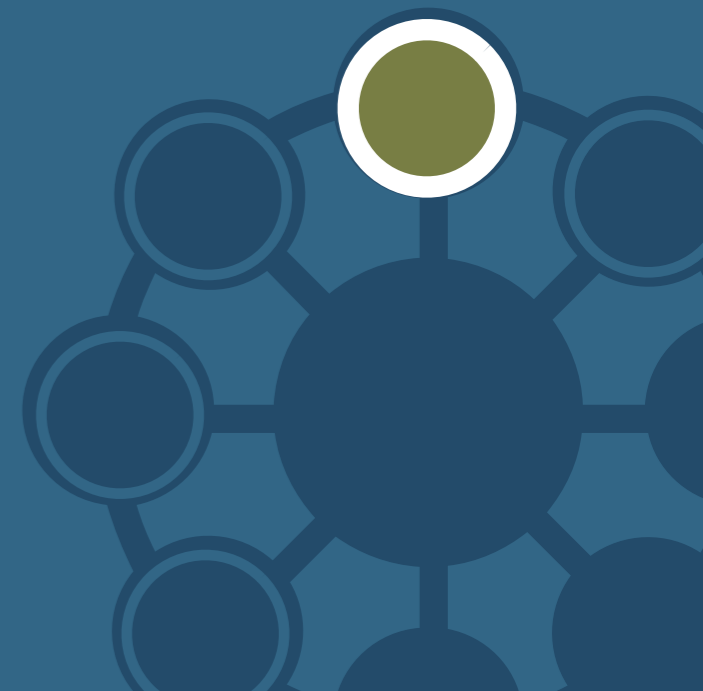
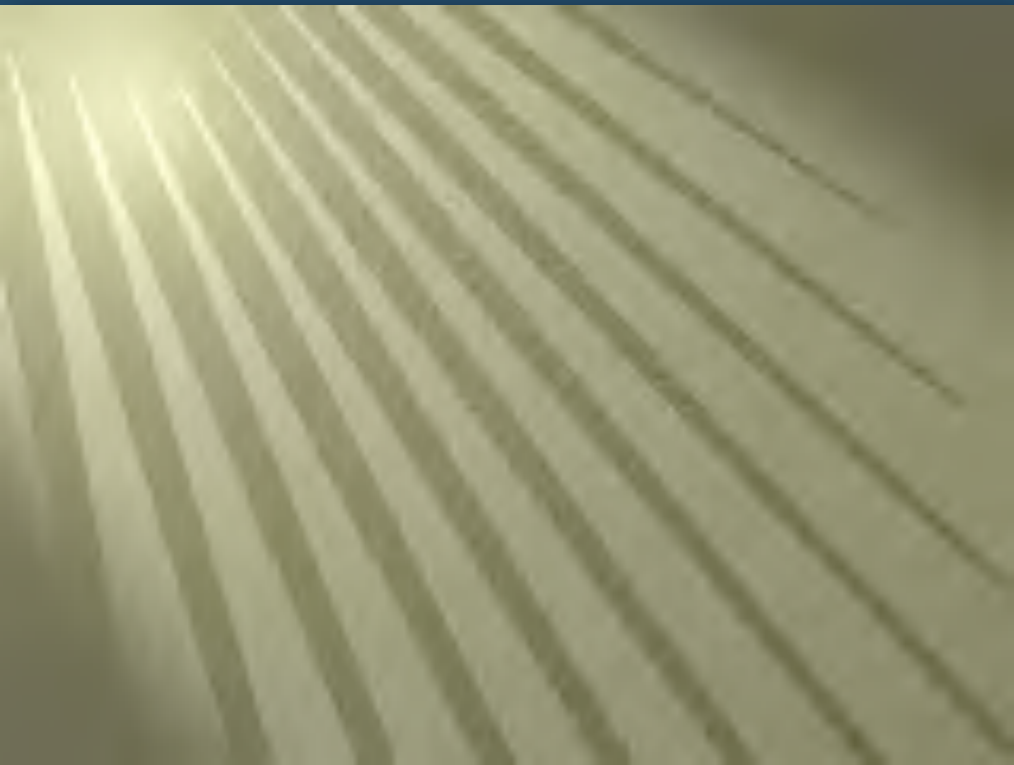

5 learn from guests
by asking for
their input

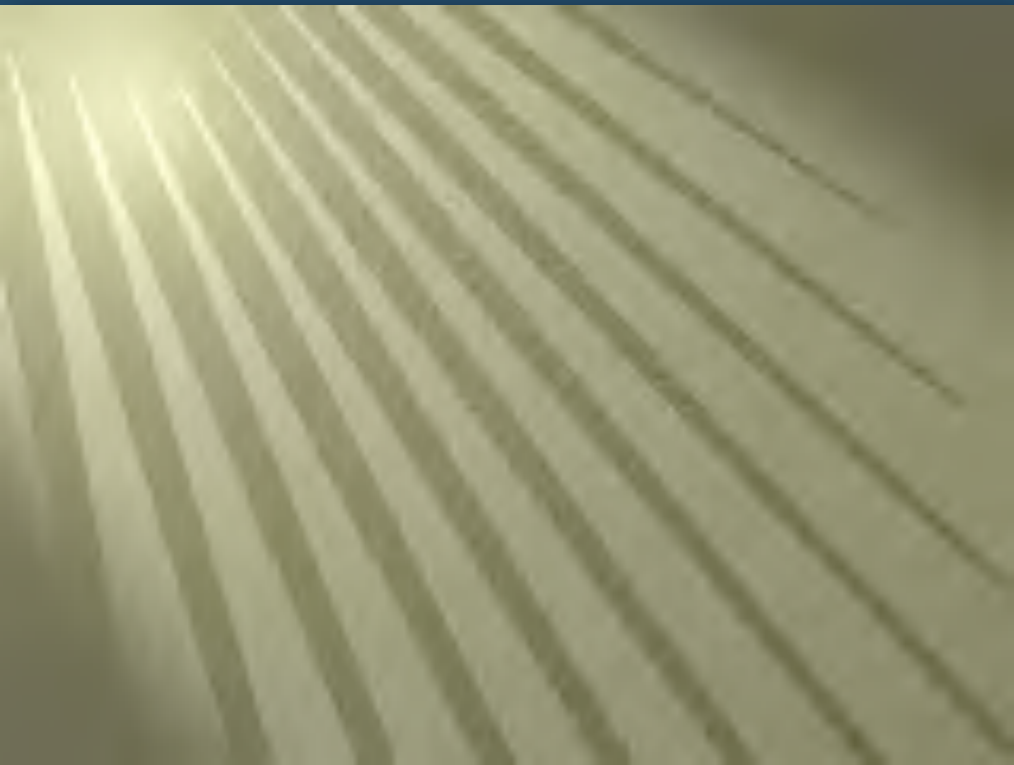



“You can always count on
the Americans to do
the right thing...

but only after they have
EXHAUSTED
every other possible option.”

-Winston Churchill

The New York Times

Sharp Cut in Burning of Fossil Fuels Is Urged to Battle Shift in Climate

“The Earth has been warmer
in the first five months of this year
than in any other comparable period
since measurements began 130 years ago...”

June 24, 1988



“you must be the
CHANGE
you wish to see in the
WORLD...”

-Mahatma Gandhi

QUESTIONS

Keynote - Tomorrow at 8am
Innovative Models - Tomorrow at 11am

ericcoreyfreed

eric@organicarchitect.com
DROP OFF YOUR BUSINESS CARD

CONNECT:



DOWNLOAD THIS PRESENTATION OF 388 SLIDES:

dodosapiens.com

QUESTIONS

Green Schools - Tomorrow at 9:30am
Booksigning - Tomorrow at 11am

CONNECT:



DOWNLOAD THIS PRESENTATION:

organicarchitect.com/downloads/hospitality.pdf

DROP OFF YOUR BUSINESS CARD

THESE SLIDES:

**contain additional notes
& ideas not shown in
presentation. They are
included in this PDF for
your enjoyment.**



GRAND HOTEL

Greta Garbo
John Barrymore
Joan Crawford
Wallace Beery
Lionel Barrymore



GRAND HOTEL

A Metro-Goldwyn-Mayer PICTURE



HOTEL



WHAT CAN WE CHANGE?

MEN

2

urinals

1.5
gpf

2

toilets

2
gpf

2

sinks

2.5
gpm x 15

0
gpf

0.8
1.6
gpf

1.5
gpm x 10

NEW

WOMEN

3

toilets

2
gpf

2

sinks

2.5
gpm x 15

0.8
1.6
gpf

1.5
gpm x 10

NEW



A 10 percent reduction in energy costs is equivalent to increasing ADR by \$0.83 for limited service hotels and by \$2.45 for full-service hotels.

**\$11 increase in RevPAR
(Revenue per available room)**



Direct Injection Ozone Laundry System typically reduces chemicals, water and sewer usage 40% & energy to heat water 60%; Utilities rebates cover up to 80% of upfront investment & GSI's leasing packages ensure monthly cost savings far exceed regular payments.

- Reduce chemicals usage an average of 40 percent with Ozonated water;
- Extend the life of linen at least 25 percent by eliminating many chemicals harmful to textiles;
- Cut water and sewer bills 40 percent through the elimination of rinse cycles;
- Expand hotel laundry operations' capacity by eliminating rinse cycles — Shaving 7 minutes off the typical laundering process for every load, enhancing machine production and life significantly while bolstering employee productivity; and
- Reduce the energy required to heat water 60 percent to 80 percent;

energy use

Hospitality spends \$3.7 billion a year on energy.

Electricity use accounts for 60-70 percent of the utility costs of a typical hotel.

America's 47,000 hotels spend \$2,196 per available room each year on energy

\$2,405,000,000 spent on electricity =

12,657,894,737 (12.66 billion kW)

enough to power 1,146,548.44 homes

4,389,443 hotel rooms

= 12,657,894,737 kW / 4,389,443

= 2883.71 kW per room

energy savings

Hospitality spends \$3.7 billion a year on energy.
39% is gas, so, \$1.443 B spent on gas / \$1.16 per therm
1,243,965,517.2 therms gas used

Using calculator: <http://www.epa.gov/cleanrgy/energy-resources/calculator.html>

ELECTRICITY SAVINGS:

6.33 B kW saved
4,545,976 metric tons of CO2 saved
10,572,037 barrels of oil saved
eliminates 1 coal power plant

GAS SAVINGS:

1,243,965,517.2 therms saved
6,219,828 metric tons of CO2 saved
14,464,715 barrels of oil saved
eliminates 1.3 coal power plants

TOTAL SAVINGS:

10,765,804 metric tons of CO2 saved
25,036,752 barrels of oil saved
eliminates 2.3 coal power plants

NEEDED:

5.8 B metric tons of CO2 emissions globally
need to cut 10%, or 58 M metric tons by 2020 to meet 2000 levels
need to cut 25%, or 1.45 B metric tons by 2050 to meet 1990 levels

hotels could save 10,765,804 metric tons of CO2
so hotels cut 7.43% of our 1990 CO2 goals for 2050 (25% reduction)
or 19% of our 2000 CO2 goals for 2020 (10% reduction)

OIL IMPORTS:

hotels could save 25,036,752 barrels of oil every year

Annual Oil Imports:

Libya	37,000,000
UAE	1,474,000
Argentina	17,595,000
Egypt	5,605,000
France	32,468,000
Germany	19,192,000
S. Korea	17,657,000
Vietnam	10,628,000

DATA: http://tonto.eia.doe.gov/dnav/pet/pet_move_impqus_a2_nus_ep00_im0_mbb1_m.htm



OIL IMPORTS:

hotels could save 25,036,752 barrels of oil every year

Annual Oil Imports:

Libya	37,000,000
UAE	1,474,000
Argentina	17,595,000
Egypt	5,605,000
France	32,468,000
Germany	19,192,000
S. Korea	17,657,000
Vietnam	10,628,000

DATA: http://tonto.eia.doe.gov/dnav/pet/pet_move_impcus_a2_nus_ep00_im0_mbb1_m.htm

RevPAR

Green hotels show higher:

AVERAGE RATE FOR AN OVERNIGHT ACCOMMODATION

RevPAR (Revenue earned per available room)

Customer Satisfaction

PKF Capital Managing Partner Henry Bose told a conference here on green hotels. "For every dollar you can add to the bottom line of a San Francisco hotel, more than \$11 is added in value,"

He noted that the USGBC has recorded dramatic savings in large green commercial buildings the size of hotels—30% energy savings, 35% less carbon output, 50% less water and as much as 90% less waste. USGBC also reported a decrease in operating costs of as much as 9% for sustainable commercial buildings and an increase of 7.5% in value and a 6.6% higher return on investment.

"It is important to note that hotels are extremely resource intensive, open 24 hours, 7 days a week, whereas commercial buildings are used primarily only during business hours. That means the financial benefits of operating a green hotel are likely to be much higher than what USGBC says about the commercial office sector," says Bose. "Hotels that are less costly to operate are simply more valuable to owners."

A 10 percent reduction in energy costs is equivalent to increasing ADR by \$0.83 for limited service hotels and by \$2.45 for full-service hotels.

operational
housekeeping
efficiencies

local food in
restaurant

multi function
rooms
(movable)

design doors
on hold
opens

fruit

68 percent of U.S. hotels said they had energy-efficient lights, and two thirds had implemented towel- and linen-reuse programs, up from just over half five years ago.

11 Minimum Guidelines for Going Green

Below is a list of actions properties of any size should take to stake their claim as an eco-friendly establishment. Each step contains further tactics, including case studies, statistics, and additional resources. AH&LA members who have further questions may get one-on-one advice from our [Green Guru](#).

1. Each hotel should form an [Environmental Committee](#) that is responsible for developing an Environmental Green Plan for energy, water, and solid waste use.
2. Manage your hotel's [environmental performance](#) by monitoring the electric, gas, water, and waste usage information on a monthly and annual basis.
3. Replace [incandescent lamps](#) with compact fluorescent lamps wherever possible.
4. Install [digital thermostats](#) in guestrooms and throughout the hotel.
5. Implement a [towel and/or linen reuse](#) program.
6. Install [2.5-gallons per minute showerheads](#) or less in all guestroom baths and any employee shower areas.
7. Install [1.6-gallon toilets](#) in all guestrooms.
8. Implement a [recycling program](#) --including public spaces -- to the full extent available in your municipality; document your efforts.
9. Implement a [recycling program for hazardous materials](#) found in fluorescent bulbs, batteries, and lighting ballasts through licensed service providers.
10. Purchase [Energy Star](#) labeled appliances and equipment.
11. All [office paper products](#) should have 20% or more post consumer recycled content.

lighting

Guest lighting accounts for 30-40 percent of hotel electricity consumption.

Energy-efficient lighting can save 20-75 percent in energy use.

water use

Typical hotels use 218 gallons of water per day per occupied room.

Water-efficient fixtures can reduce water and sewer bills by 25-30 percent.

perception |

Deloitte Survey

Independent on line survey of 1555 business travelers 4/08

71% believe the lodging industry is only 'somewhat' green

perception 2

Deloitte Survey

Independent on line survey of 1555 business travelers 4/08

23% say the lodging industry is not at all green.