

# A retrospective of early adoption of ASHRAE Guideline 36

**CX**associates<sup>LLC</sup>

*Rick Stehmeyer - Senior Engineer*

[rick@cx-associates.com](mailto:rick@cx-associates.com) | Burlington, VT | Portland, ME

v: 802.861.2715

f: 802.861.2717

blog: [buildingenergy.cx-associates.com](http://buildingenergy.cx-associates.com) | web: <http://www.cx-associates.com/>



Note: If you're reading this in PDF Format, please keep in mind it was sourced from a presentation and there are queue's to click listed in the notes that would trigger animations in the presentation. Please ignore these queues in the following notes.

About Presenter:

Rick Stehmeyer is a senior engineer at Cx Associates in Burlington, Vermont.

Started in 2002 => 18 years in the biz

<Click>

# About Me

---

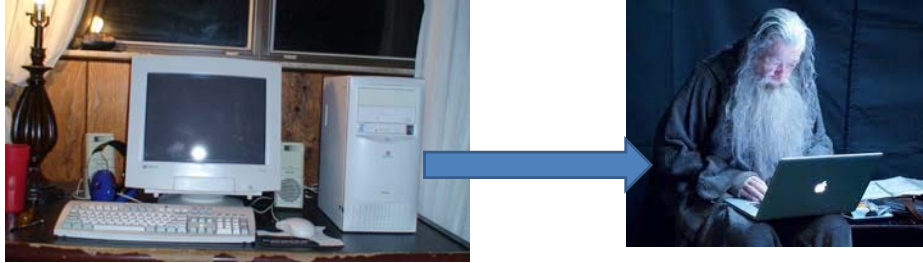

2

CXassociates LLC

I studied computer science in college when computers looked like this.

which makes me feel like this today <click>

I applied for an internship at a controls company right next to my college campus and happened have a natural talent for programming installing these <next>

## About Me



And I caught the HVAC bug working there

I am the only LONworks Certified professional in Vermont (only guy to take the test).

I have integrated these in R2 and Ax through proprietary drivers and open system communications protocols.

In my time I have programmed, installed and maintained the following controls products directly <click>

Barber Coleman DMS, Network 8000, and IA series controls (now owned by SE)

Johnson Fx Controls (legacy and current gen)

Honeywell Spydors

Alerton

Reliable Controls

Distech

Tridium Jaces through Niagara Ax

# About Me

---



4

CXassociates<sup>llc</sup>

And now I am the most dangerous of all professions in the HVAC industry <click>

An engineer

# Presentation Overview

---

- Big Picture
- Fanny Allen 2015
  - Design Process
  - Guideline 36's implementation
- Fanny Allen 2016
  - Construction Process
  - Guideline 36 installed in Vermont
- Fanny Allen 2020
  - Current Facility Operation
  - How much Guideline 36 is still in operation

CXassociates<sup>llc</sup>

**In this presentation we originally had a representative from the control's contractor and the hospital as co-presenters. But life happens and they cannot be here today.**

**plan on telling the story of the Fanny Allen Hospital BAS upgrade.**

**Within this story I'll talk about Guideline 36.**

**I will refer to it as "the guideline" or GL36 through our this presentation.**

**We'll talk about UVMHC's Fanny Allen Hospital**

**We'll start Fanny's story with the BAS upgrade design and make our way to current day.**

**But lets start at the very very beginning**

# Big Picture

CLIMATE AND ENVIRONMENT The New York Times

## Climate and Environment

### Japan Races to Build New Coal-Burning Power Plants, Despite the Climate Risks

As many as 22 new coal plants—one of the dirtiest power sources—will arise at 17 sites across Japan, just as the world must slash emissions to fight warming.

### Fireflies Have a Mating Problem: The Lights Are Always On

Habitat loss and pesticides are threatening firefly populations, a new study has found. It also cited a problem unique to glowing bugs: light pollution.

### NOAA Leaders Privately Disowned Agency's Rebuke of Scientists Who Contradicted Trump

Newly released emails show officials at NOAA told the agency's scientists it did "not approve or support" a controversial agency statement issued after the president falsely said that Alabama was at risk from Hurricane Dorian.

### Trump Administration Moves to Relax Rules Against Killing Birds

A proposed

CXassociates LLC

why are we here today?

I hope you are sitting here because you're concerned with climate and the environment.

Yesterday (2/4/2020 the NY Times reported that Japan will build 22 coal power plants in the near future.

This breaks my heart.

# Energy Consumption in USA by Source

## U.S. primary energy consumption by energy source, 2018

total = 101.3 quadrillion  
British thermal units (Btu)

total = 11.5 quadrillion Btu

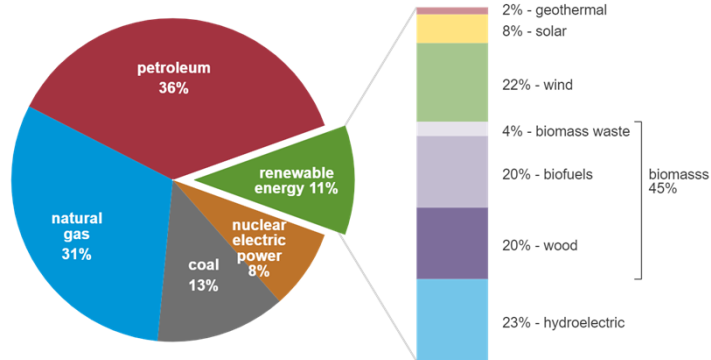

Note: Sum of components may not equal 100% because of independent rounding.  
Source: U.S. Energy Information Administration, *Monthly Energy Review*, Table 1.3 and 10.1, April 2019, preliminary data



CXassociates LLC

**Overall in the United states, energy consumption for 2018 was majority fossil fuel!**

**Renewables are 11%**

# Energy Consumption in USA

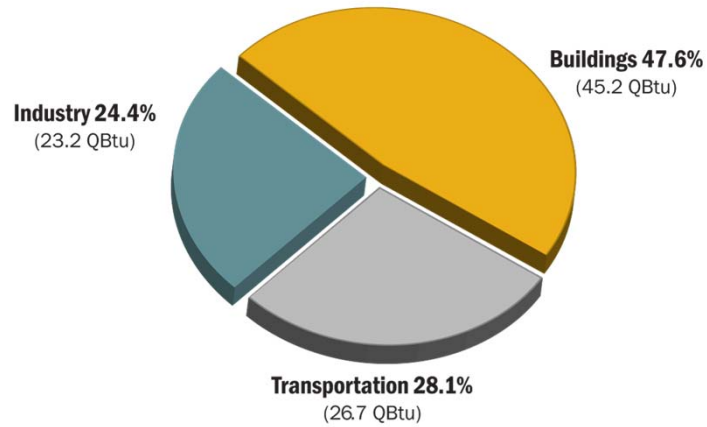

**U.S. Energy Consumption by Sector**

Source: ©2013 2030, Inc. / Architecture 2030. All Rights Reserved.  
Data Source: U.S. Energy Information Administration (2012).

**CX**associates<sup>llc</sup>

**In 2013 the EIA reports that buildings are 47.6% of US energy Consumption**

**Buildings are 47%! That's our 47% here at BBBD**

**We own that in this room.**

**We own the responsibility for shrinking it.**



# Big Picture Atmospheric CO<sub>2</sub>

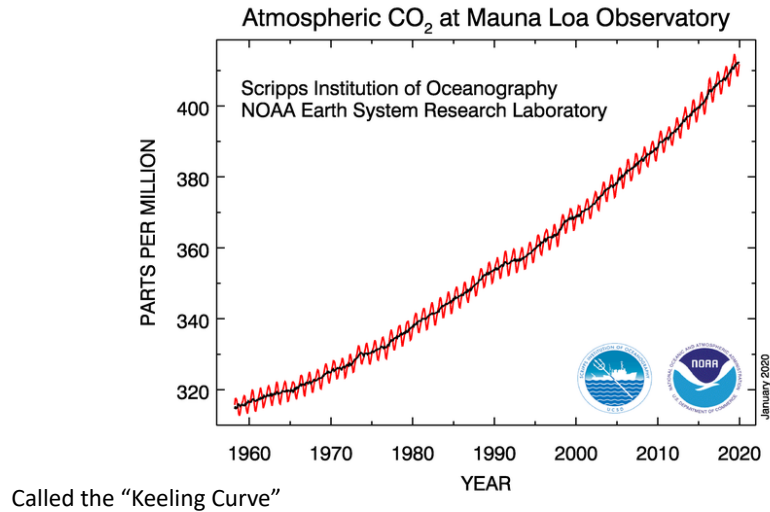

Cxassociates LLC

**This is Atmospheric CO<sub>2</sub> in my parent's lifetime. My parents are still kicking and haven't even retired yet.**

# Big Picture Atmospheric CO<sub>2</sub>

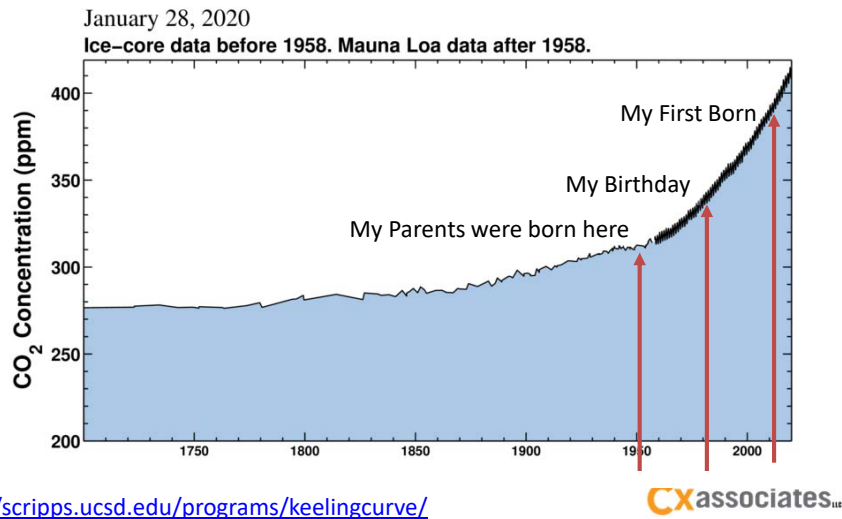

Here is its since the year 1700.

The dark black is the previous graph.

Here are three generations of Stehmeyer on this graph.

# 1993



CXassociates<sup>llc</sup>

**I love star trek. (Lots of it here in this presentation)**

**Star trek showed a future without social injustice, greed, money, and poverty. A future where we learn from our mistakes.**

**A future where humans made decisions by studying problems using the scientific method and arriving conclusions that turned into actions.**

**In 1993 there was an episode where they find out warp speed travel damages space.**

**It destroys the “environment” of space so to speak.**

**Picard at the end of the episode says to Geordi**

**that he has spent his entire life traveling space to learn about it and all that time he has been damaging the thing he holds most dear.**

**Geordi reassures him that “we still have time”**

# Atmospheric CO<sub>2</sub>

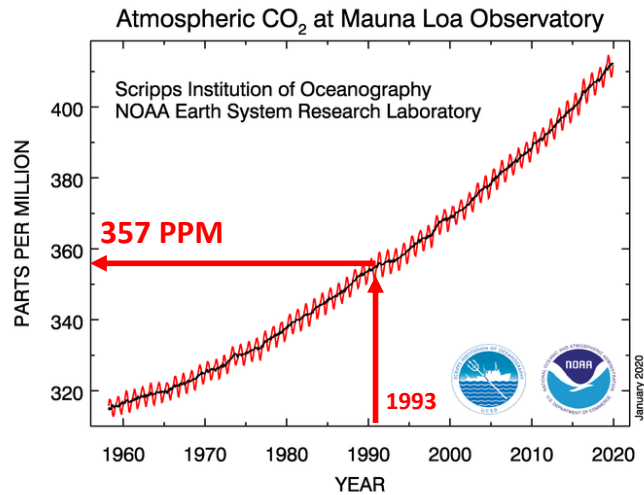

Cxassociates LLC

I was 12 years old in 1993 we knew the CO<sub>2</sub> was rising because of humans. We made the characters of star trek address it then and sent a message to impressionable young viewers.

We knew why.

It was at 357 PPM

Here in the future, in 2020, we are out of time.

# 80% CO<sub>2</sub> in USA 2018

## U.S. primary energy consumption by energy source, 2018

total = 101.3 quadrillion  
British thermal units (Btu)

total = 11.5 quadrillion Btu

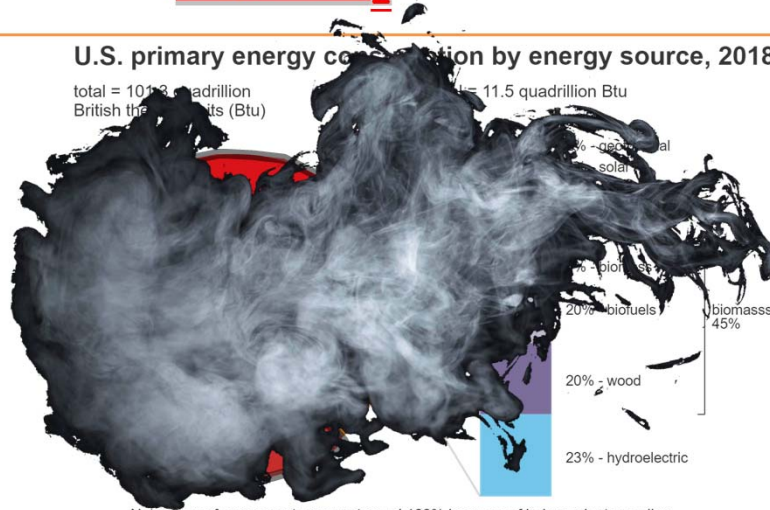

Note: Sum of components may not equal 100% because of independent rounding.  
Source: U.S. Energy Information Administration, *Monthly Energy Review*, Table 1.3 and 10.1, April 2019, preliminary data



Cxassociates LLC

In 2018, 80% of this graph is carbon emitting.

That's disgusting.

## Actions Speak Louder than Words

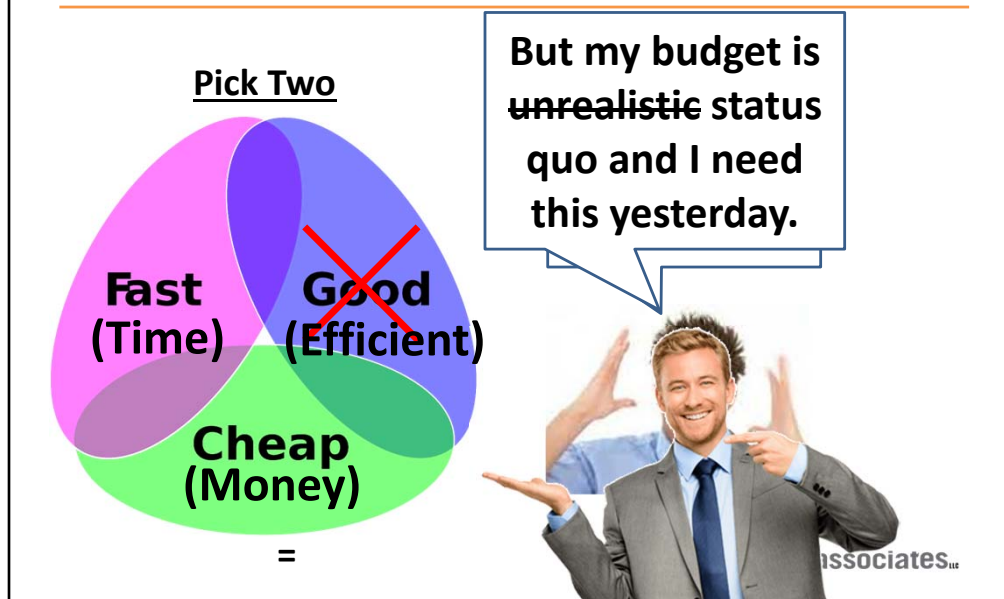

As a commissioning agent I deal with the construction industry daily.

In design, construction, and building upkeep we are bound to budgets and timelines.

We want buildings to be built better by design. We want buildings to be efficient. But that comes at a significant first cost compared to the 2020 status quo. <Click?

Last year I had two clients start LEED design projects and cancel them before the design was finished. Can you guess why the “LEED” component was canceled?

The reality is that Efficiency takes time and money. If you don't have both, you're not going to hit the target efficiency you're looking for because time is money. (click)

Which is why what I am going to show you with Fanny took time and money to get to good. It was not a quick project and it wasn't a cheap upgrade.

That being said, its an investment in efficiency that pays back over time, which we know is money.

# YOU NEED TO ACT TODAY

---

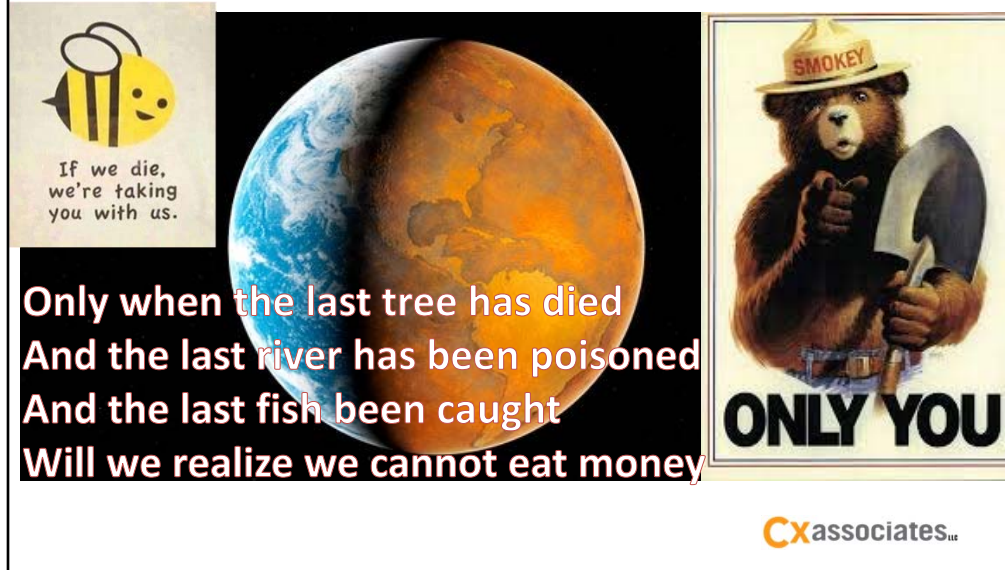

If we die,  
we're taking  
you with us.

Only when the last tree has died  
And the last river has been poisoned  
And the last fish been caught  
Will we realize we cannot eat money

SMOKEY

**ONLY YOU**

CXassociates<sup>llc</sup>

**We all are responsible for this future we know we are creating for ourselves.**

**If you've not made this a daily thought or priority – in personal life or as a business participant, you must start now.**

# For Tomorrow

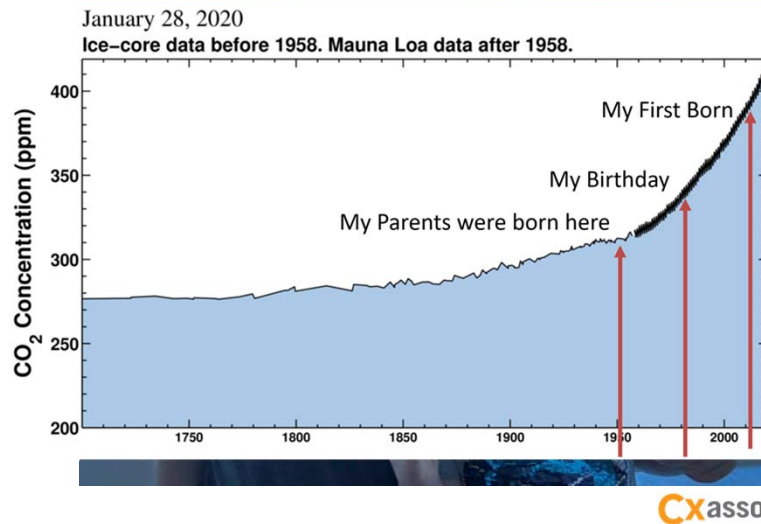

Last slide on this, I promise.

My 8 year old and 5 year old have no idea how bad it is right now.

When they're my age, I hope they will be able to say that their parents never stopped trying to prevent the climate.

Its time for each of us to use our unique positions, abilities and resources to stop this problem NOW.

We need to change the way its always been done. Its going to be inconvenient, and expensive, but you can't eat money so it's an investment we must make for our children and ourselves.



## The most dangerous phrase



17

CXassociates<sup>llc</sup>

Guideline 36 is hard.

Its complicated.

Its expensive BECAUSE its not the way we've always done it.

When we make it the way, it will no longer be expensive, because it will be copy paste tweak.

We want to save energy. That means working harder and using systems smarter.

Image Source: <https://pbs.twimg.com/media/CoDZrP8XEAEydEK.jpg>

# ASHRAE Guideline 36-2018



ASHRAE Guideline 36-2018

## High-Performance Sequences of Operation for HVAC Systems

Approved by ASHRAE on June 4, 2018.

This Guideline is under continuous maintenance by a Standing Guideline Project Committee (SGPC) for which the Standards Committee has established a documented program for regular publication of addenda or revisions, including procedures for timely, documented, consensus action on requests for change to any part of the Guideline. The change submittal form, instructions, and deadlines may be obtained in electronic form from the ASHRAE website ([www.ashrae.org](http://www.ashrae.org)) or in paper form from the Senior Manager of Standards. The latest edition of an ASHRAE Guideline may be purchased from the ASHRAE website ([www.ashrae.org](http://www.ashrae.org)) or from ASHRAE Customer Service, 1791 Tullis Circle, NE, Atlanta, GA 30329-2305. E-mail: [orders@ashrae.org](mailto:orders@ashrae.org). Fax: 478-539-2129. Telephone: 604-636-8600 (toll-free), or toll free 1-800-527-4721 (for orders in US and Canada). For reprint permission, go to [www.ashrae.org/permissions](http://www.ashrae.org/permissions).

© 2018 ASHRAE ISSN 1049-894X

18

CXassociates LLC

So we are going to choose the new way, the harder way. For the sake of our future and to make buildings better by design.

Image Source: <https://pbs.twimg.com/media/CoDZrP8XEAEydEK.jpg>

# PURPOSE!

---

## 1. PURPOSE

The purpose of this guideline is to provide uniform sequences of operation for heating, ventilating, and air-conditioning (HVAC) systems that are intended to maximize HVAC system energy efficiency and performance, provide control stability, and allow for real-time fault detection and diagnostics.

- Reduce Engineering time
- Reduce Programming and Commissioning time
- Reduce Energy Consumption
- Improve Indoor Air Quality
- Reduce System Downtime by Including Fault Detection Diagnostic Algorithms
- Provide a Common Language of Terms to facilitate communications between specifiers, contractors, and operators

19

CXassociates<sup>llc</sup>

**Purpose:** Provide uniform sequences of operation for HVAC systems that are intended to maximize HVAC system energy efficiency,

- performance,
- provide control stability,
- and allow real-time fault detection and diagnostics

**Basically the guideline provides unified technical techniques and terminology with the goal of reducing time for everybody.**

## Designers and Implementers Working Together



Contractor

Engineer



20

CXassociates<sup>llc</sup>

The end goal is to reduce time for both design engineers and control contractors by uniting them under common practice while advancing the state of the art.

This wont happen overnight, it needs ADOPTION by the design community. This only happens when customers ask for it.

In the future, the ideal situation is that controls manufacturers will adopt Guideline 36 like they did BACnet and provide tools for their dealer networks to easily provide, modify, and configure these pre-programmed sequences.

RP 1587 - Control Loop Performance Assessment

## Information for the Design Engineer

---

*Notes in italics between thin lines provide guidance or additional information about specific sequences.*

*These notes are not a part of this guideline. They are merely informative and do not contain requirements necessary for conformance to the guideline.*

**Notes in bold between thick lines provide direction to the editor of these sequences so that they are properly implemented (e.g., identifying mutually exclusive options).**

The guideline really speaks to you in various ways.

One is the Italicized notes to the reader (you) that provide context into what and why we're asking you to do these things listed in the sequence.

The other is the bold notes which are the choose your own adventure decisions every engineer must make in design. <Click>

## Choose your own adventure

---

The engineer must select between ventilation logic options:

- If the project is to comply with ASHRAE Standard 62.1 ventilation requirements, keep subsection (a) and delete subsection (b).
  - If the project is to comply with California Title 24 ventilation requirements, keep subsection (b) and delete subsection (a).
- 



22

CXassociates<sup>llc</sup>

For example here you can see that we need to pick between AHSRAE standard 62.1 and California Title 24 and use the appropriate sequence for the applicable codes in your area.

# Starting Point

## CONTENTS

ASHRAE Guideline 36-2018

High-Performance Sequences of Operation for HVAC Systems

SECTION	PAGE
Foreword .....	2
1 Purpose .....	2
2 Scope .....	2
3 Set Points, Design, and Field Determined .....	2
3.1 Information Provided by Designer .....	2
3.2 Information Provided by (or in Conjunction with) the Testing, Adjusting, and Balancing Contractor .....	9
4 List of Hardwired Points .....	10
4.1 VAV Terminal Unit—Cooling Only .....	11
4.2 VAV Terminal Unit with Reheat .....	11
4.3 Fan-Powered Terminal Unit (Series or Parallel, Constant- or Variable-Speed Fan) .....	12
4.4 Dual-Duct Terminal Unit with Inlet Sensors .....	12
4.5 Dual-Duct Terminal Unit with Discharge Sensor .....	13
4.6 Multiple-Zone VAV Air-Handling Unit .....	13
4.7 Dual-Fan Dual-Duct Heating VAV Air-Handling Unit .....	15
4.8 Single-Zone VAV Air-Handling Unit .....	15
5 Sequences of Operations .....	16

23

CXassociates<sup>llc</sup>

Right off the guideline starts by defining setpoints and design variables that the designer needs to consider.

Although the setpoints may be changed during the construction verification process on your project, they should be included in your design documentation and customized for your project's needs.

## Temperature Control Characteristics Setpoint Design & Field Determined

Zone Type	Occupied		Unoccupied	
	Heating	Cooling	Heating	Cooling
VAV	21°C (70°F)	24°C (75°F)	16°C (60°F)	32°C (90°F)
Mech./Elec Rooms	18°C (65°F)	29°C (85°F)	18°C (65°F)	29°C (85°F)
Networking/Computer	18°C (65°F)	24°C (75°F)	18°C (65°F)	24°C (75°F)

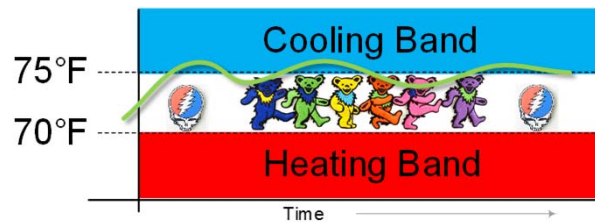

24

**CX**associates<sub>llc</sub>

The guideline then provides you some starting suggested setpoints.

Notice the 5°F deadband? <click>

Nice right?



## Multiple Zone VAV AHUs Setpoint Design & Field Determined

*Instructions for establishing MinDP are given in the Test and Balance Specification. For example:*

- 1) Open the minimum outdoor air damper and return air damper fully; close the economizer outdoor air damper.*
- 2) Measure outdoor airflow.*
- 3) If outdoor airflow rate is above design minimum (DesVot for ASHRAE Standard 62.1 or DesMinOA for California Title 24, adjust damper linkage on minimum outdoor air damper so that intake is at design minimum with damper fully stroked.*
- 4) If outdoor airflow rate is below design minimum, temporarily adjust return*

**They even include language on what to include in the T&B specification**

# Guideline Overview and Systems

## G. Multiple Zone VAV Air Handling Unit with Return Fan and OA Measurement Station

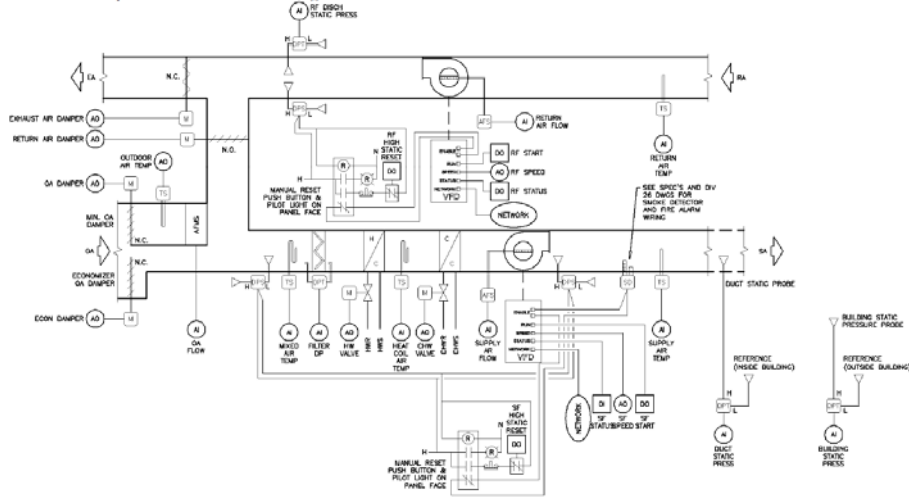

26

They not only provide sequences, but also layouts for equipment, we'll get into this more later in the presentation when we talk about... <click>

Image Source: GPC36 PPR1 05-16-2016

# Fanny Allen

---



**Cx**associates<sup>llc</sup>

**Fanny.**

**Fanny Allen hospital is in Colchester and is part of the UVMHC family.**

**In 2015 Cx Associates was contracted to design a comprehensive BAS upgrade for the facility.**

## Willing to go the distance

---



THE  
University of Vermont  
MEDICAL CENTER

28

CXassociates<sup>llc</sup>

I'd like to acknowledge that UVMHC is very committed to taking the time and putting the effort into energy efficiency.

Nobody forced them to take the hard road, or budget for a more expensive approach to a BAS upgrade.

From the beginning they were committed to doing the hard thing, investing both time and money into their building to make it the most efficient that it could be.

This first cost will pay off over the life of the building.

They knowingly chose to do it better than the way its always been done.

# The way its always done:

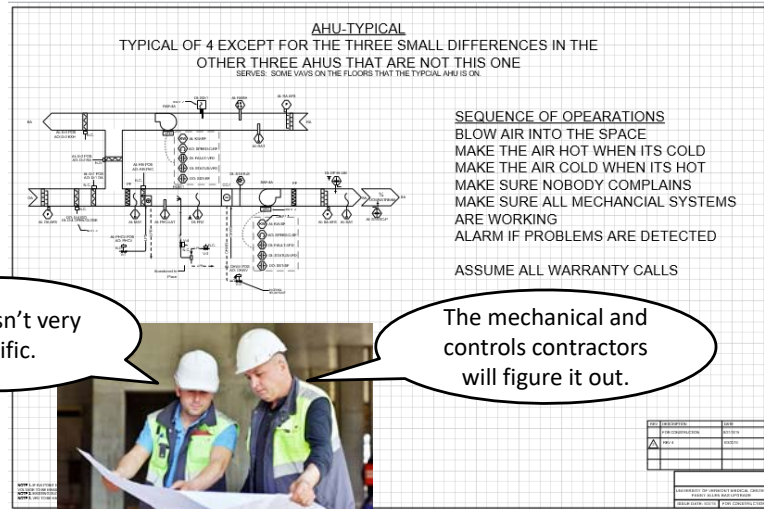

Sir, this isn't very specific.

The mechanical and controls contractors will figure it out.

29

Cxassociates LLC

Often times controls contractors are the last to get started as their work is predicated on the other trades being completed

They are under tight budgets that result in low bid pricing battles.

They also are generally given poor direction and are the ones left to "Make it work". This too can impact the race to the bottom for pricing.

In these situations, you commonly hear: "that wasn't specified, we'll need a change order"

Not at Fanny Allen. They were made part of a team, they had input and helped out. They were given the time and the resources they needed to get the job right.

Image Source: <https://pbs.twimg.com/media/CoDZrP8XEAEydEK.jpg>

# Current Generation

Ⓜ CONSTITUTION CLASS STARSHIP U.S.S. ENTERPRISE NCC-1701

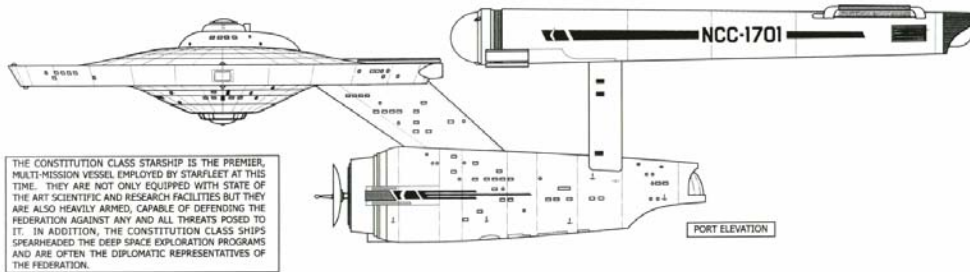

CXassociates LLC

They too brought way things have been done, <click>

# The next generation

---

**ENTERPRISE**  
1701-D

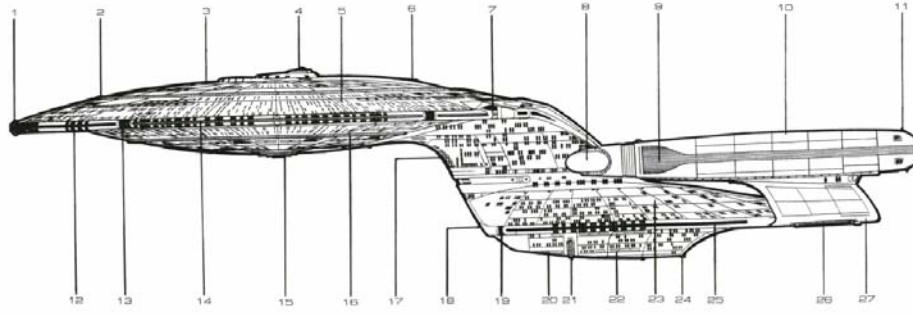

**CX**associates<sub>llc</sub>

to the next generation <click>

# Commissioning

---



32

**UVMCC was committed to 3<sup>rd</sup> party commissioning for this project.**

**This is a must with Guideline 36 because**



## Guideline 36 – Verified on the West Coast

---



33

CXassociates<sup>llc</sup>

Initially GL36 was verified on the west coast.

## Guideline 36 – In New England

---

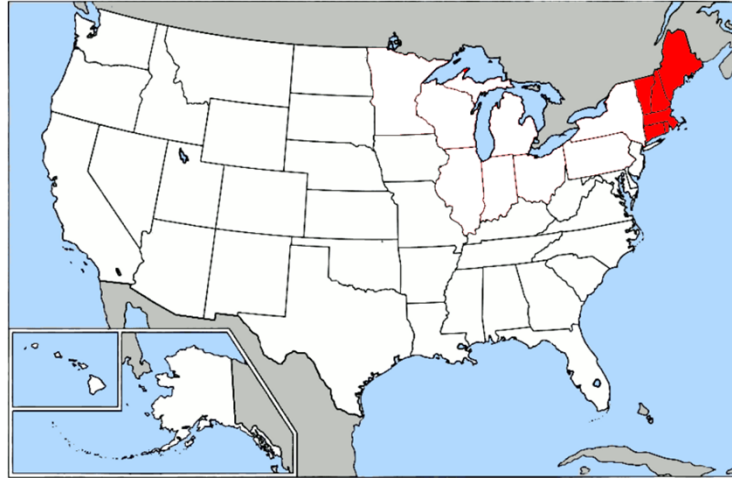

34

So at the time we had to translate those sequences of operation to northern New England,

you can't take everything for granted.

## Guideline 36 – In New England

---



35

CXassociates<sup>llc</sup>

**The team spent the time during design to put on our thinking caps and evolve status quo HVAC control sequences**

## Guideline 36 – An Evolution

---



36

**If we take cars for example.**

**Cars have evolved their status quo.**

**In the 70s, the dashboard were simple.**

**There was very little information provided to the driver.**

**They were inefficient too.**

## Guideline 36 – An Evolution

---



37

**In the '80s, more information is available, and efficiencies are better**

## Guideline 36 – An Evolution

---



38

**This trend continues (you must normalize MPG for increased number of cylinders, larger cylinder displacement, increased HP, increased torque between the early 90's and mid 2000's)**

# Guideline 36 – An Evolution

---



39

## Guideline 36 – An Evolution

---



until you get to the zero emission Tesla.

Tons of information is available and there is no tailpipe.

Engines have gotten more complicated with more parts. There are more electronics. As cars have become more efficient, they have become much more complex.



## Guideline 36

---

**THIS IS IMPORTANT**

## Guideline 36

---

**THIS IS IMPORTANT**

**GL 36 is NOT a car**

42

**CX**associates<sup>llc</sup>

Unlike a car, to make a typical AHU more efficient, the only hardware you **MIGHT** have to add is...

# Guideline 36

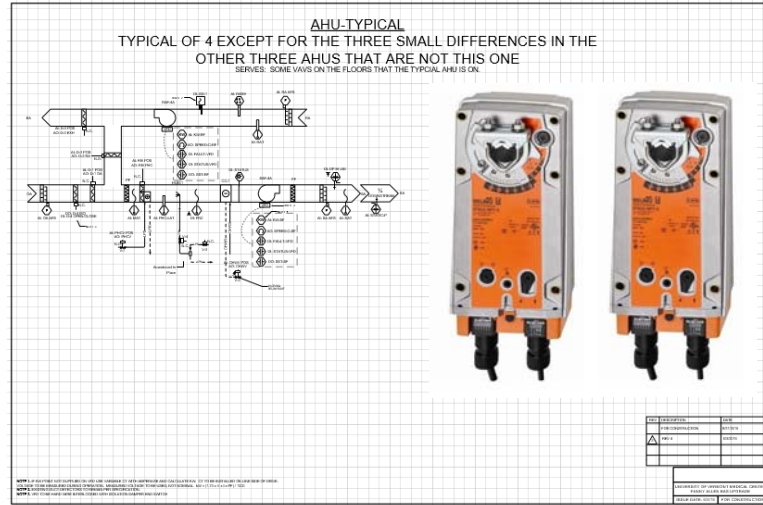

43

two damper actuators and (click)

# Guideline 36

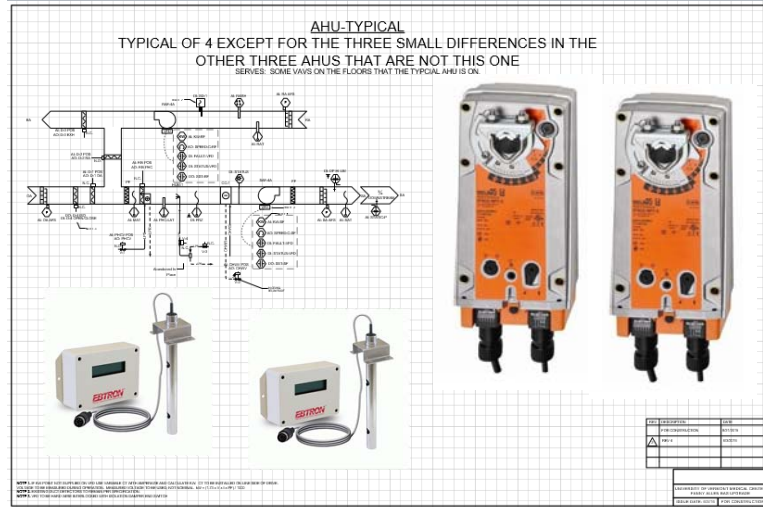

44

**Two air flow stations. That's it! All the gains that GL 36 gives us are done with more thoughtful applications of sequences of operation including better use (or the use at all) of available information.**

## Guideline 36

---

- Efficiency through smart sequences of operation.



45

**Efficiency through smart sequences of operation. (Click)**

## Guideline 36

---

- Efficiency through smart sequences of operation, not tons of new hardware.



46

**Not tons of new hardware**

# Guideline 36

Status Quo

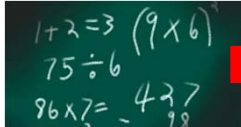

Status Quo

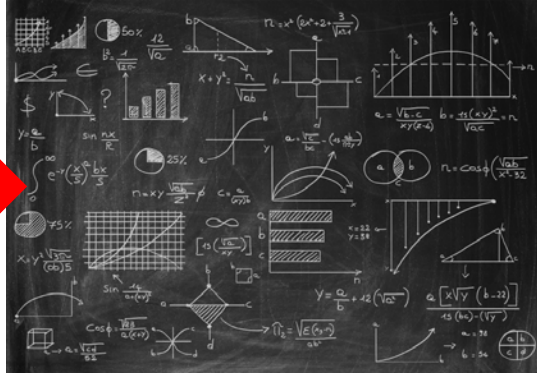

47

Sequences are more complex and more involved than the status quo,

**They require more programming, and more verification because more is done in software.**

**This requires better graphics.**

**This requires people to step up, step outside the comfort zone, and get to know something more complex.**

## Guideline 36 – Design and Commission It!

---

- Efficiency through smart sequences of operation, not tons of new hardware.
- Sequences are more complex and more involved than the status quo.
- 3<sup>rd</sup> party verification is a must.
  - Independent commissioning should be included to ensure the implementation matches the design



## Guideline 36 – Design and Commission It!

---

- Smart sequences, complex controls require thoughtful planning.



49

CXassociates<sup>llc</sup>

**You need a designer with pertinent experience and expertise.**

**You need to allow TIME TO COMPLETE THE DESIGN – The FAH project required an exhaustive survey of the building as a starting point.**

**You need to be willing to consider the best proposal for the work, NOT THE CHEAPEST.**

# First Cost and Building Construction

The image shows a screenshot of a Google Shopping search for "doctors". The search results are sorted by price from low to high, as indicated by the red circle around the "SORT BY PRICE - LOW TO HIGH" dropdown menu. The results list three doctors:

- Doc. Hackemoff MD.**
  - Organ replacements, and removals for less
  - 50% off kidneys (for a limited time only)
- Doc. Wisenheimer G.B.**
  - Good listener
  - Laughter is the best medicine
- Good health associates**
  - Provide real services, cost more money

The page also includes a sidebar with filters for "Show only", "Price", and "Brand". The "Price" filter is set to "Up to \$25". The "Brand" filter is set to "Doctor's Best".

50

CXassociates LLC

**There are just some areas where folks see the value in paying more upfront.**

Buildings need to be in this mindset for all of us moving forward as they can have tremendous environmental impacts.

## Guideline 36 – Design and Commission It!

---

- Engineered documents allow for review and critique BEFORE installation.



51

Cxassociates<sup>llc</sup>

**You MUST allow time for at least one thorough review prior to finishing the design. A qualified 3<sup>rd</sup> party Cx Agent should be involved, but at a minimum you and your operating staff need to have input.**

**Why all this planning? <click>**

## How long will your building exist? How long will you pay for gas? Electricity?



52

CXassociates<sup>llc</sup>

**\$1 spent during design = \$100 during construction = \$10,000 over the lifetime of the building.**

**A cheap design is affordable today, but will incur cost for the next 20 years.**

**How many people want to heat their building for more money over the next 10 years to save a few bucks on their design today?**

**Well we, as a species, are notoriously bad at planning for our future. This is echoed in our building design choices.**

## Average Life of a BAS

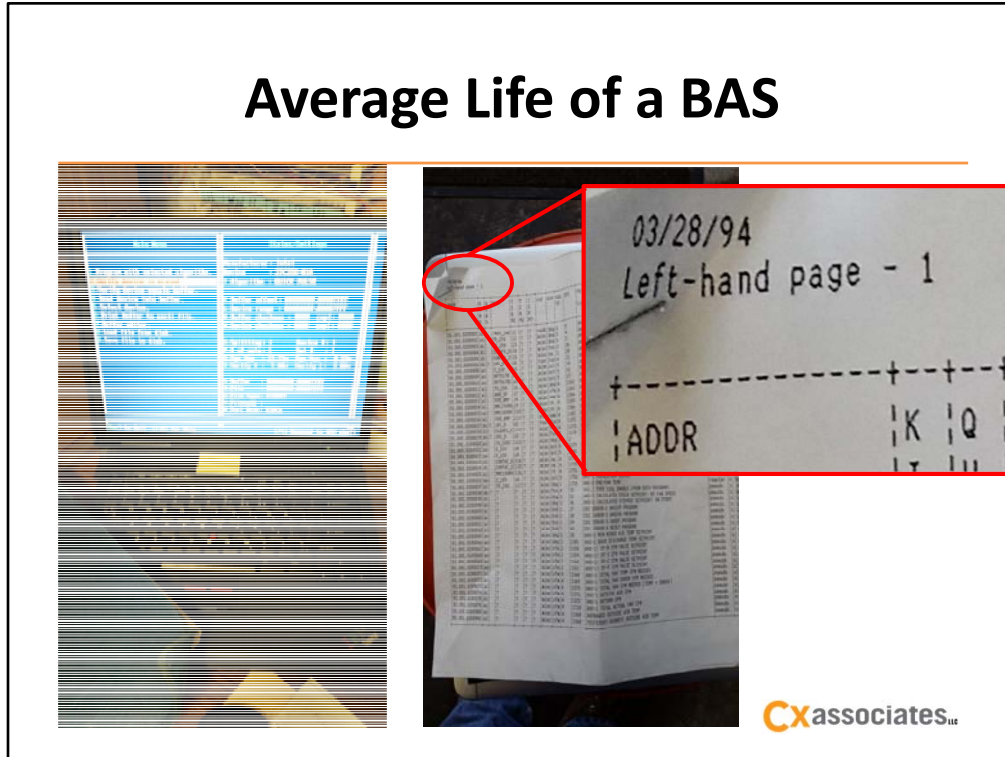

When UVMCC decided to upgrade the BAS, the system was over 20 years old.

It was installed in the early 90s.

These systems were so old, they had to keep old laptops around to modify them. This is not uncommon in the controls industry.

This BAS was old enough to serve in our military <click>,

# Average Life of a BAS

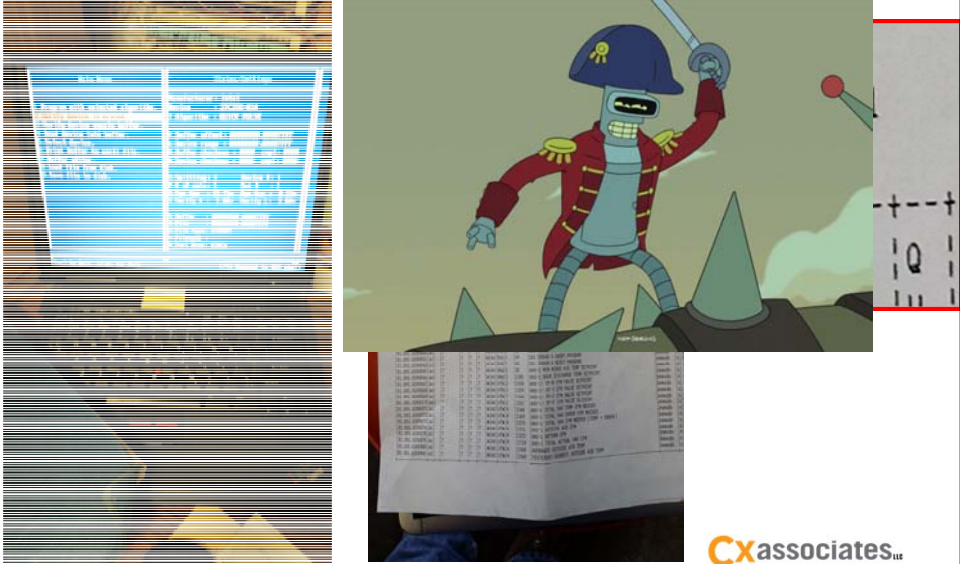

vote <click>

## Average Life of a BAS



, and drink beer <click>

## Average Life of a BAS

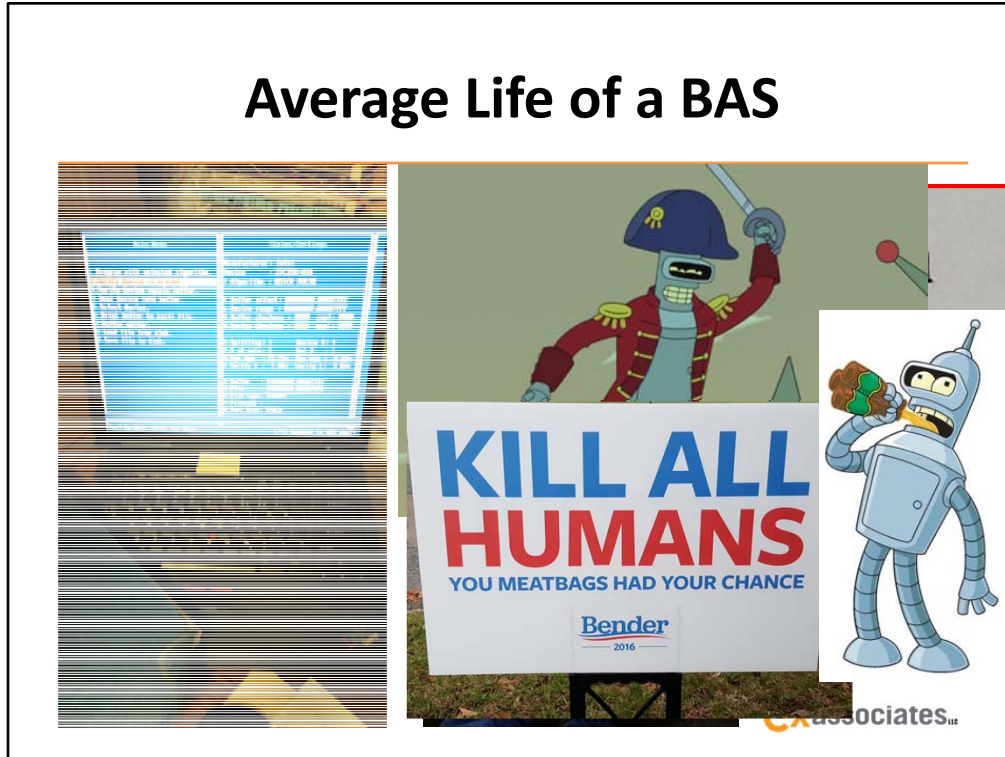

when it was replaced.

It ran 24/7 for over 20 years. You don't ask your car to do that.

UVMMC & Fanny Allen got their moneys worth from that system and then some.

This is why UVMMC knew that they should go the distance with the new system to get the same value out of it.



## Plan, Invest in your future!

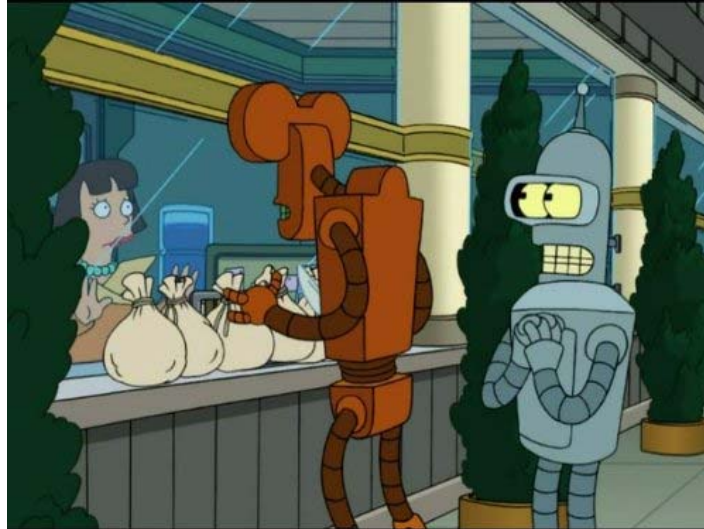

CXassociates<sup>llc</sup>

So when you hear someone cry foul about expensive BAS Systems, remember that most live for more than 20 years if maintained (and some cases even if its not maintained).

Also if your BAS is 15 years old, start saving capital for the next 5 years to purchase its replacement.

Have a plan. Take your time for good design. Upgrades can be phased to match budgets IF planning is done ahead of time.

Then a building can end up with a complex efficient system, without doing everything at once.

# Fanny Allen Design Phase Process

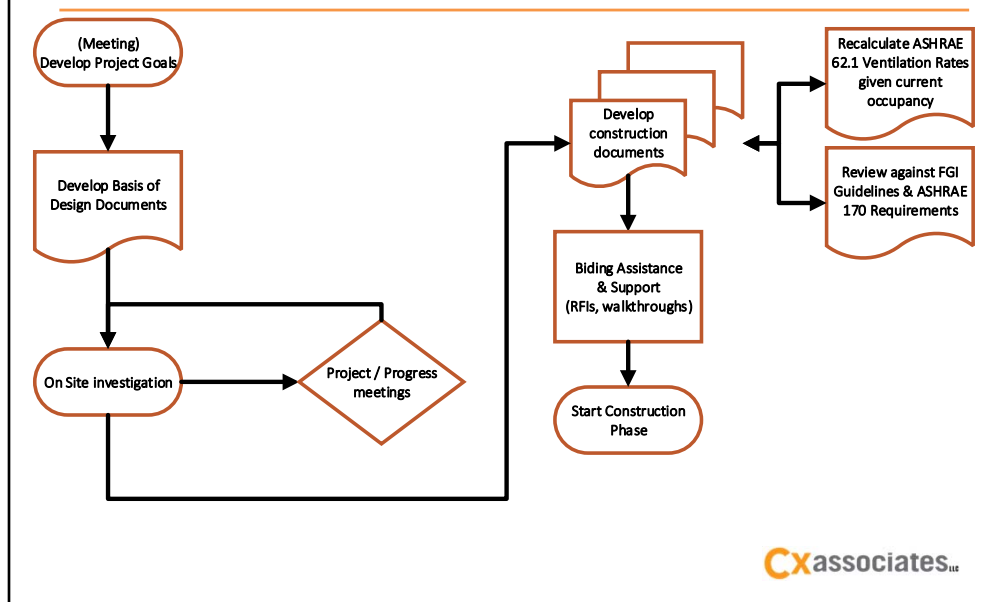

We started a design for the BAS, we had a plan.

This is just the Design Phase

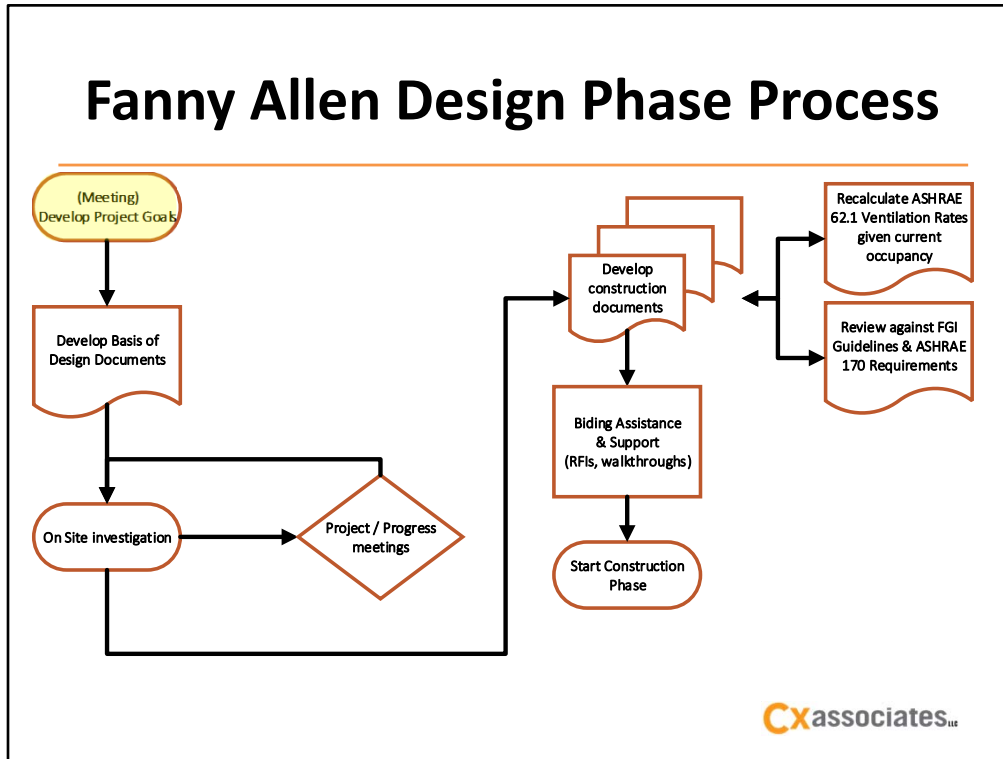

**We started the design by interviewing the stakeholders:**

**UVMMC Project management**

**UVMMC Facilities management**

**What they wanted from this upgrade. We guided them through developing project goals.**

# Fanny Allen Project Goals

## General Spec Items

- 1) BACnet Only?
    - a. There is a fair amount of existing LON discovered in the building.
    - b. BACnet is such an easier technology to work with, and since most of the wiring will need to be redone, BACnet is preferred.
      - BACnet for printing
      - Lon from
  - 2) New Server hardware or Virtual Machine provided by UVM/MC?
    - a. If new hardware - rack mount server spec?
      - Yes
    - b. If Virtual Machine, what are limitations UVM/MC imposes?
      - Yes
    - c. Do you want the ability of the system to use existing UVM/MC accounts for access so that the same password used to log in to your PC is used for the BMS? (LDAP)
      - No
      - Yes
        - i. Requires some coordination with IT dept.
        - ii. If concerned Allow for only **Admin** Staff to use their accounts
    - d. Do you want engineering software to modify the system independently of the ATC?
      - i. This is not preferred to keep cost down.
      - ii. You can always buy this later if you need it.
 

Pro	Con
Can have any ATC modify system	Adds thousands of dollars to project cost
- No to engineering software**
- Contact  
Server living on site, with remote backup to college street.
- 3) ATC to provide an "Operator Workstation" or will UVM/MC's existing computers be ok
    - a. Remember: Specifying web based system
      - Provide new PC for Operator workstation
  - 4) FID's adjustable to certain user accounts?
    - a. Can be UVM/MC Staff
    - b. Can be just Engineers/Controls Personnel.
      - Yes - On an account basis
  - 5) Do you want your new Thermostats to also sense space Humidity?
    - Humidity OR and CSR - For FCUs too - With DEHUM indicated on FCUs (Must to follow up for other spaces, might have to do at AHU level)
      - a. Currently there are a lot of VAVs with more than one space sensor. Do you want to keep this functionality (preference is yes).
        - All Digital Stats
      - b. Any new Thermostats you want added to spaces that don't have tight control historically?
    - b. Any new Thermostats you want added to spaces that don't have tight control historically?
  - 6) Fix the Electrical Meters and get them back on the BMS?

## Sequence Specific Items

- 1) Building Static Pressure Control?
  - No Go
- 2) Hard wired manual reset Freezestats? - Propose Autoresets (hard wired delay timers)
  - a. Any software responses?
    - Manual Resets = hardware
    - b. Maintenance Timers?
      - a. Runtime or schedulable?
      - b. Fan Belt Changout?
      - c. Filter Changout?
      - d. Boiler Rotate (as this will not be automatic)?
        - No and no - except for boilers
  - c. Do you want Filter DP for Dirty Filter Alarming?
    - No
- 3) Do you want zone Grouping on a per AHU basis?
  - a. Separate Occ Schedules.
  - b. Separate Optimal Start/Stop algorithms per zone
    - Yes - Make sure Optimal start/stop is enabled/disable-able
    - Indicate on graphics when on Optimal start/stop
- 4) Separately adjustable space heating and cooling set points or one single space temperature setpoint?
  - a. Preferred separate
  - b. A single will just have an offset applied to create separate set points anyway
  - c. A routine to prevent overlap is spec'd.
    - One set point only.
    - With deadband adjustable
- 5) How do you normally operate the boilers? System runs 24/7? Manually start/stop boilers?
  - Yes - manual
  - Steam pressure monitoring is a go
    - Alarming with adj. set points.
- Any Condenser Tower bypass valves in the system? - not sure, follow up with **batopax**  
How long into the fall - early/mid November (chillers are run)
- 7) Are humidifiers still active?
  - Not sure.
  - loss in case FWH available.
- 8) VAV 243 - Backup AC control?
  - For the lab, cabinet AC unit in there.
  - If AHU 9 cannot provide enough cooling, the back up ac kicks in.

ES LLC

This was essentially an interview detailing what they would like to see improved, added, and modified.

# Fanny Allen Design Phase Process

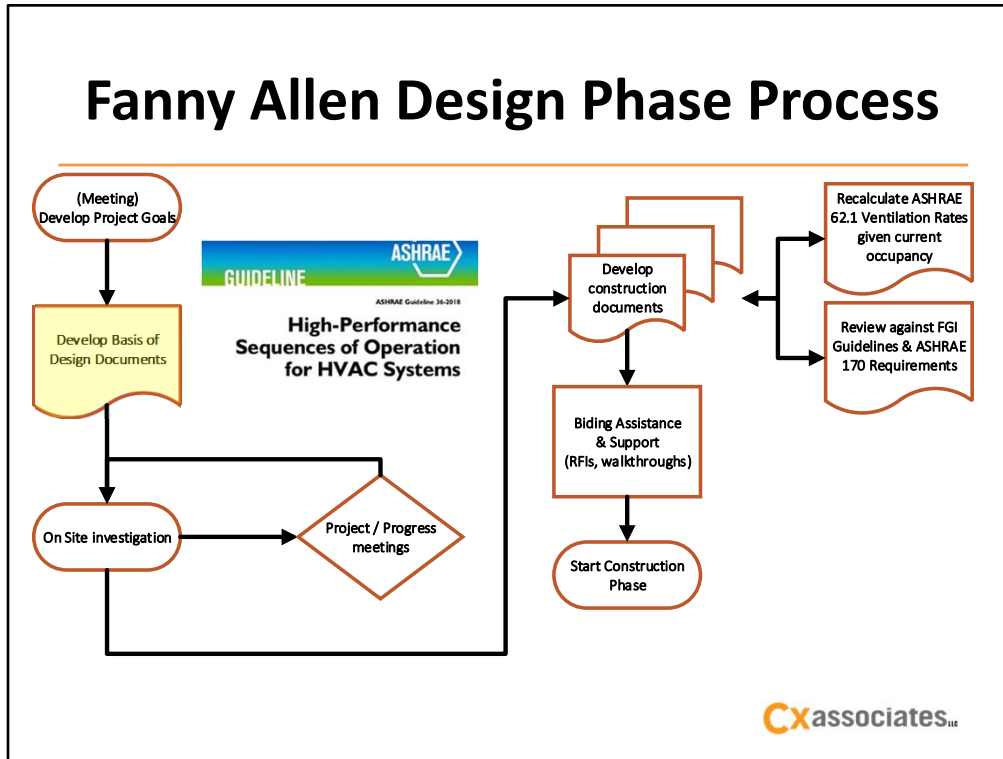

Then we developed a basis of design based on ASHRAE Guideline 36's current draft and the ownership input.

# Fanny Allen Design Phase Process

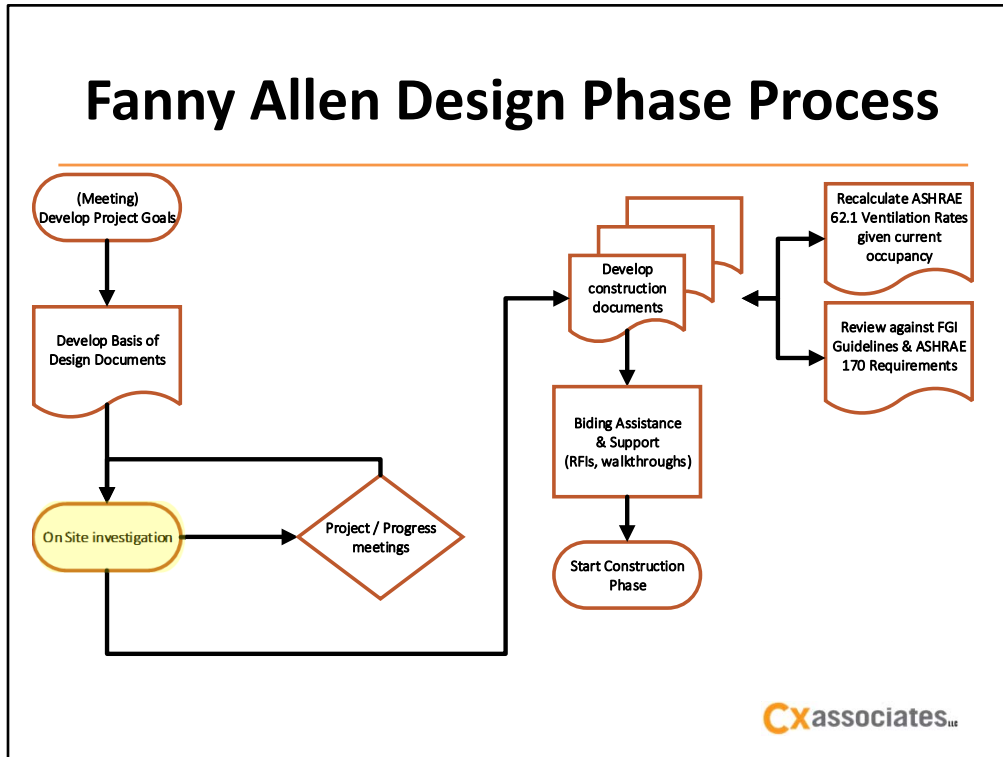

The next phase of the design required a detailed-on site investigation because the building was so old there was no good set of as-built drawings.

No one set of drawings contained a complete view of the MEP systems.

Hospitals are amalgamations of additions over long periods of time, and the drawings sets only focus on the section being added.

## Fanny Allen Site Visit

---

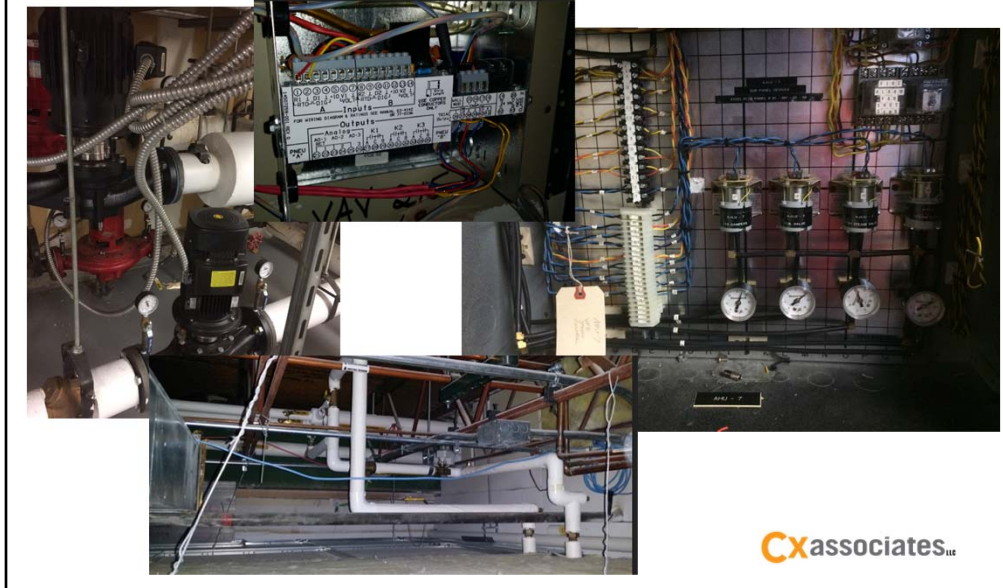



So we spent weeks on site with our team crawling through ceilings, chasing pipes and duct, and looking at equipment.

# Fanny Allen Review with UVMCC

6/29/2015 - meeting for Field Visits this week  
Monday, June 29, 2015 3:24 PM

- FCUs/VAVs/Etc
  - Thermostat locations for devices
  - Actuator Types / typical setups
  - Confirm Electric / Pneumatic Thermostat combinations
    - o What controls what?
  - Baseboard radiation?
  - Check if FCU has actuated OAD
  - Valve body tags for any pneumatics
  - List Occupancy Sensors and Locations
    - o Get a model number if possible
- For each AHU
  - Measurements for OA Stations
  - Photos on OA stations
- Get areas served by AHU 7
- Get areas served by AHU 5



During that time we had periodic meetings with Fanny's facilities team to ask questions about operations and how things behaved.

We created a detailed list of mechanical deficiencies and issues that would hinder the BAS controls from being able to provide the most value.

UVMCC budgeted a healthy contingency for all the MEP deficiencies so that they could repair equipment or systems found not to be 100% functional.



## Fanny Allen Evaluation of Equipment

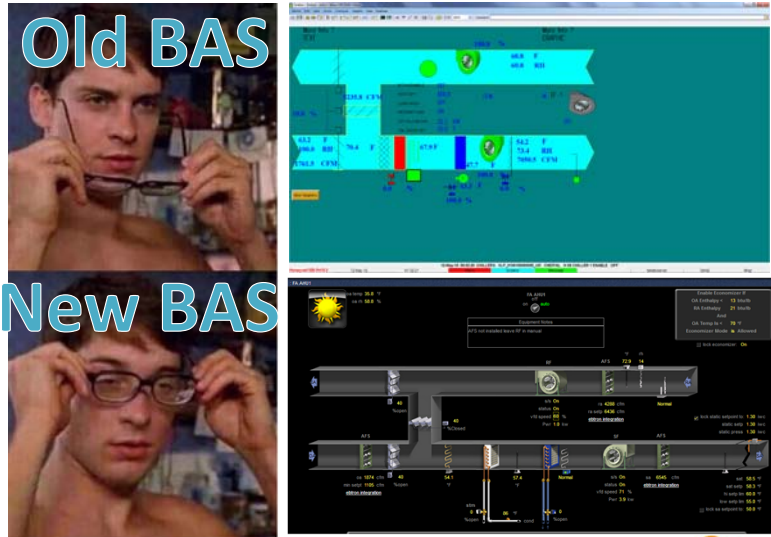

CXassociates LLC

Both UVMC and CxA knew that a BAS is only as good as the mechanical equipment its controlling.

For any BAS upgrades, in any building, you will typically add more sensors and replace old inaccurate ones. Trending will be improved; response times will be improved.

The new BAS allows users see their existing mechanical equipment more clearly, and therefore makes the mechanical issues more visible

We wanted to try to get ahead this as much as possible to inform UVMC.

So they could plan their contingency budget.

# Fanny Allen Design Phase Process

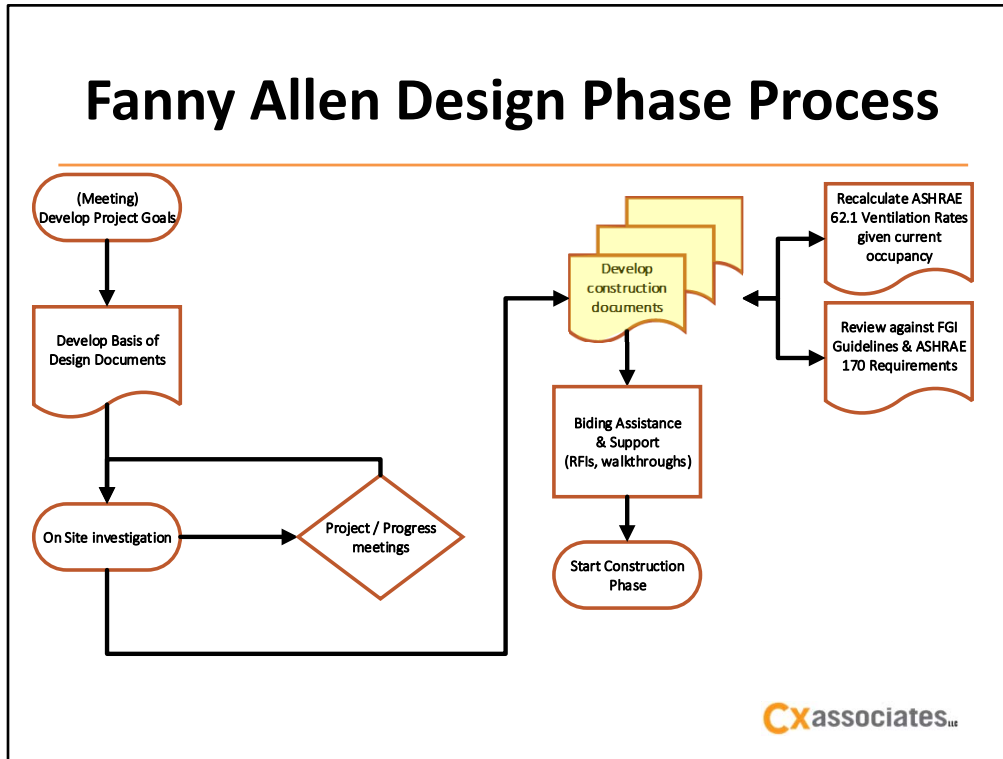

From all that site work and preparation between the customer and ourselves, we were able to develop a comprehensive view of the equipment, the spaces, and their uses.

# Fanny Allen As-Built Development

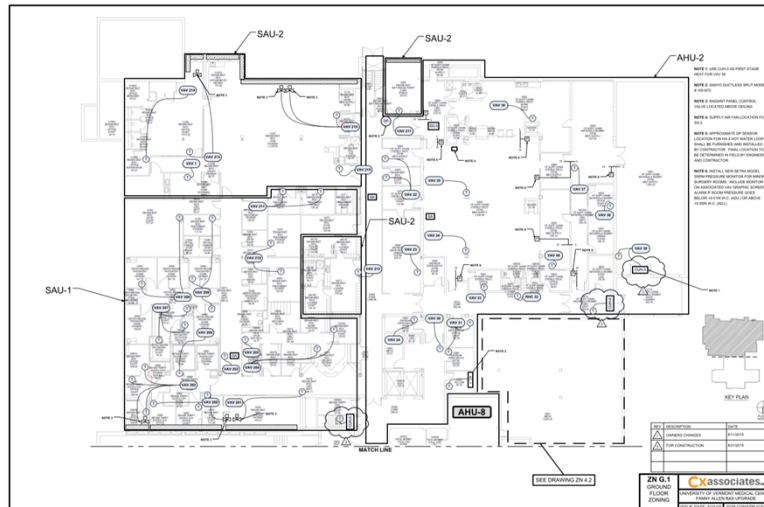

This drawing set is now the *goto* set for the facilities team.

This was not a fast or inexpensive.

Remember Time = Money

However the payback on this investment is immeasurable if you consider the time it saves their staff today.

This was also very important to the design efforts because <click>

# GL36 Terminal Units

---



ASHRAE Guideline 36-2018

**High-Performance  
Sequences of Operation  
for HVAC Systems**

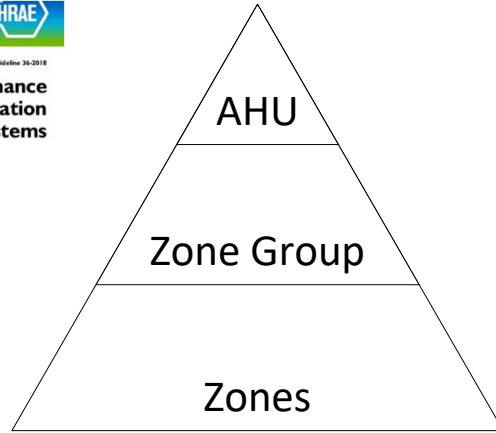

The Guideline builds on a common theme of hierarchy's

# WARNING – FORK AHEAD

---

Fanny  
Allen

ASHRAE  
Guideline 36



69

Cxassociates<sup>llc</sup>

Just a heads up, we're going to get into some of the guideline here, we'll come back to Fanny in a moment.

## Status Quo – Open Loops

---

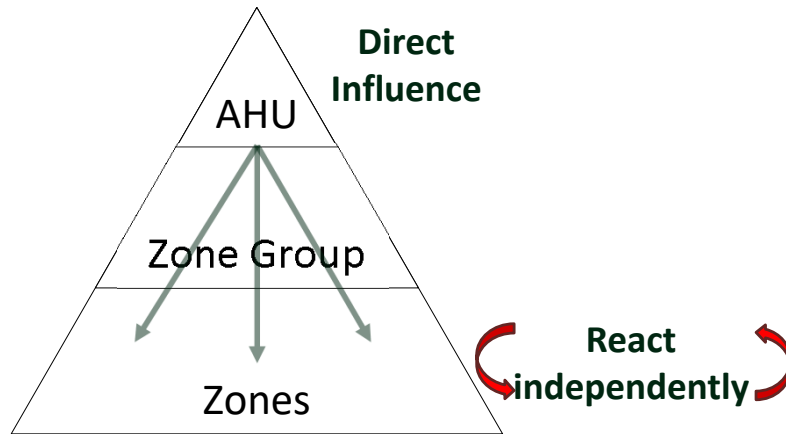

70

CXassociates<sup>llc</sup>

Status Quo sequences generally treat each of these systems as independent.

Of course they are connected mechanically,

but industry standard sequences generally make the AHU's provide what they're going to provide

and the zones react independently.

In this setup, the AHU drives the zones. The zones react.

This is open loop control

## Conventional – Open Loop SAT Reset

---

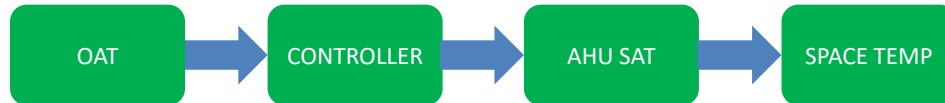

Multizone AHUs

CXassociates<sup>llc</sup>

A common example of open loop control is Outside air reset.

# Open Loop – No Feedback

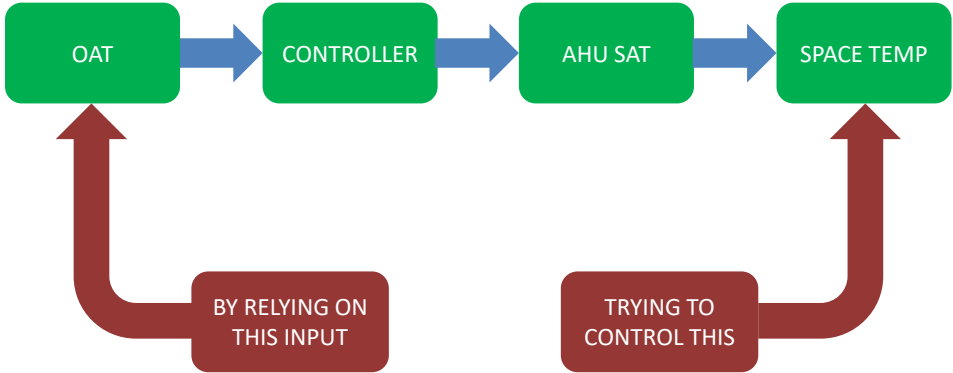

CXassociates LLC

By looking at the current OAT, a design engineer assumes what the impact on the space will be.



## Open Loop – No Feedback

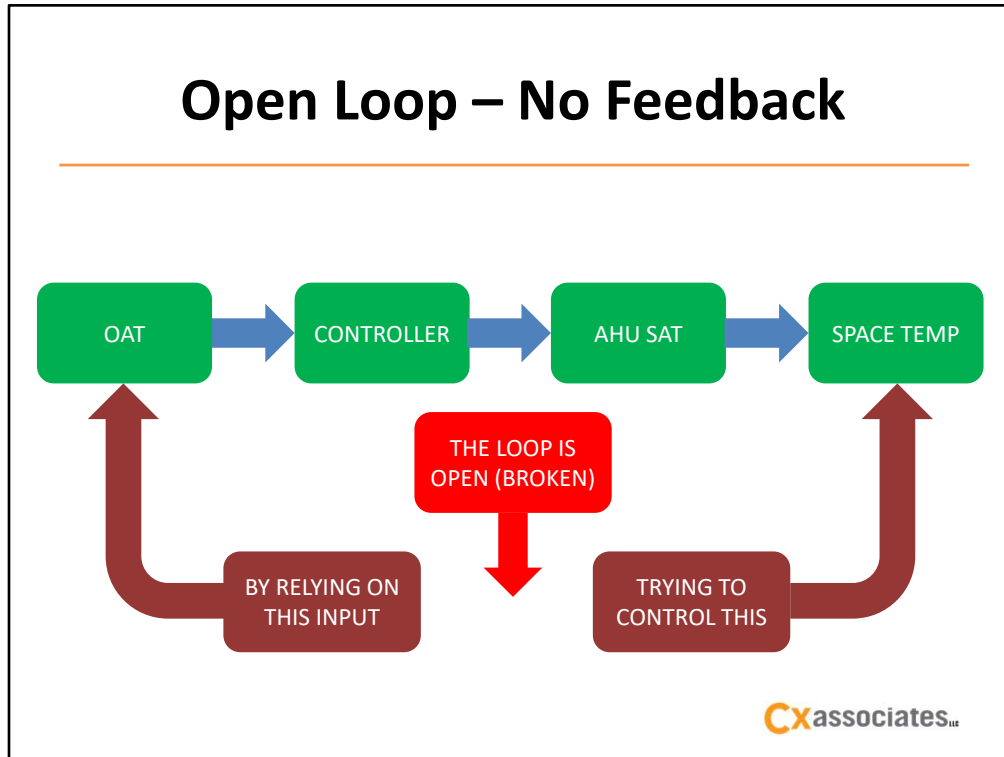

You can see that Open loop controls do not use a feedback from the process (space temp) to inform what they are doing.

This is an old sequence from when building envelopes were poor.

## Conventional – Open Loop SAT Reset

---

OAT Determines SAT

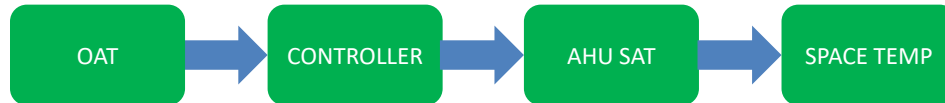

CXassociates<sup>llc</sup>

This was the old way. How do we make it better?

## How to Close the Loop

---

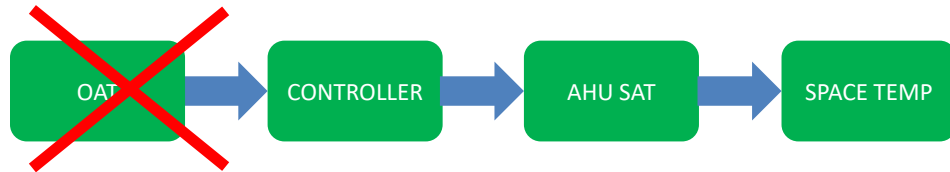

CXassociates<sup>llc</sup>

**Remove the input that doesn't know anything about the final output of the control loop.**

**We need to provide the controller with a new input that is affected by the controller output.**

## Guideline 36 Closed Loop SAT Reset

SAT Control – GL 36 – Heating / Cooling Requests – Closed Loop

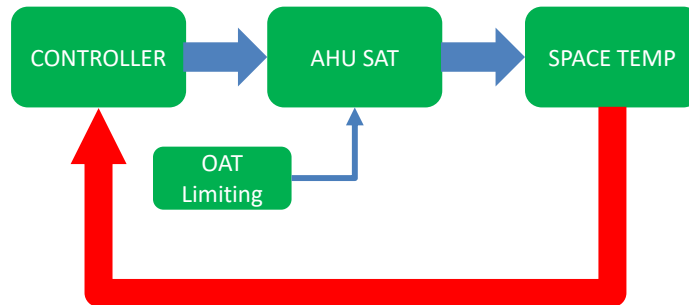

Allow the output we want controlled (the space) to tell the controller what to do.

The Guideline also still allows OAT to impact the reset limits, but the reset itself is based entirely on space temperature heating / cooling requests.

OA is still INFLUENCING the load; it's just not directly controlling the H/C delivered to the space

# GL36 Closes the Loops

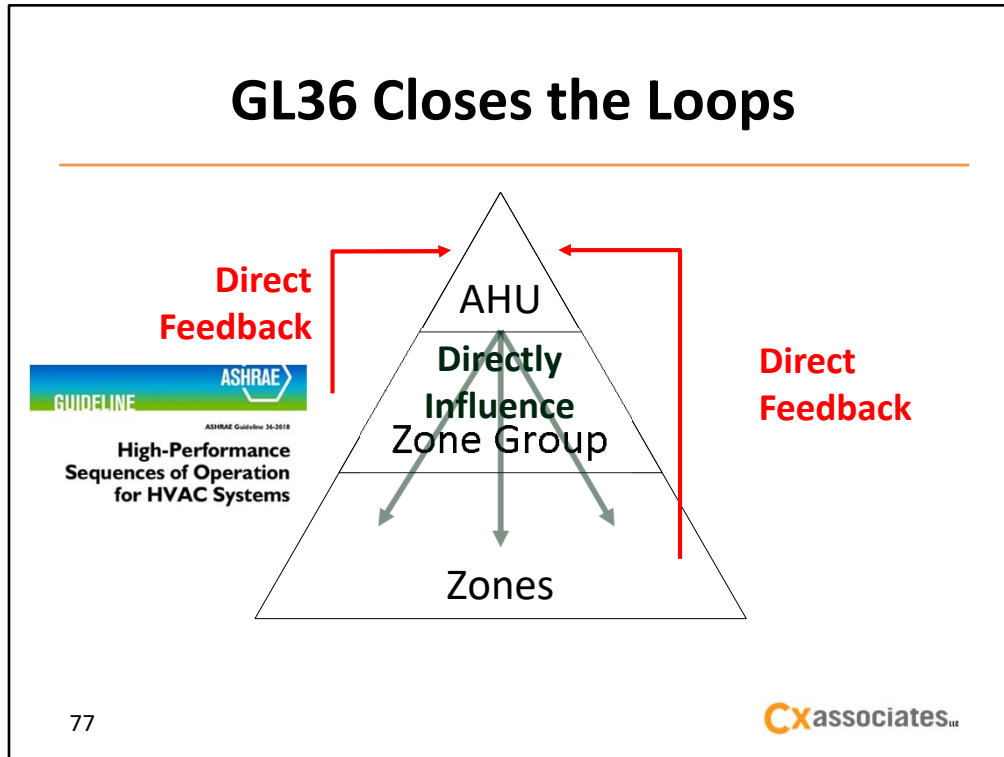

In Guideline 36 each zone directly send signals up to the equipment feeding it which have an impact on the AHUs, and hydronic plants serving them.

This closes the control loop

This concept includes Thermal, ventilation, pressure, alarming.

# Importance Multiplier

SAT Control – GL 36 – Heating / Cooling Requests – Closed Loop

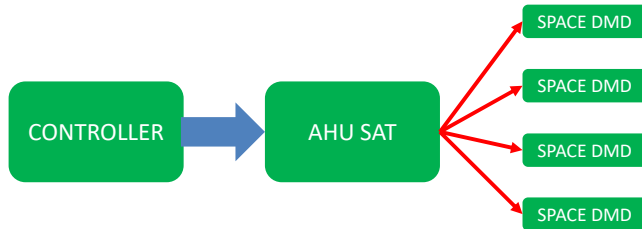

CXassociates<sup>llc</sup>

Now we go a step further, this is how the zone send signals up to the equipment feeding it.

Every AHU serves multiple spaces.

Some of those spaces are more important than others.

Some are larger, some are more critical, etc.

# Importance Multiplier

SAT Control – GL 36 – Weighted Heating / Cooling Requests – Closed Loop

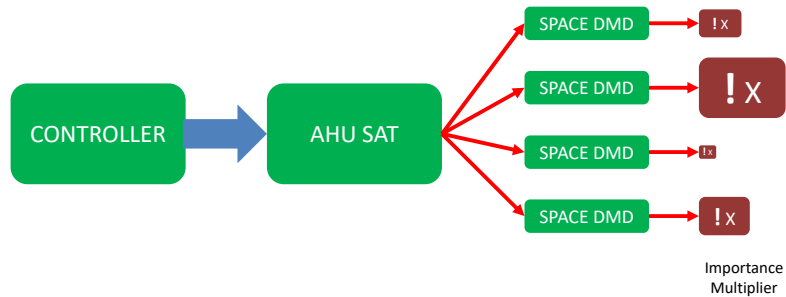

CXassociates<sup>llc</sup>

We assign each space an “importance multiplier”. In the GL, these are numbers between 0 and 1 by default.

If a zone requires more importance you can go above 1 increasing the number of requests a zone generates.

If a zone shouldn't impact upstream AHUs / Plant equipment you can set the multiplier to 0 causing it to be ignored.

These multipliers are used to add weight Heating / Cooling Requests passed up to the AHUs or Central Plant equipment.

# Importance Multiplier

SAT Control – GL 36 – Weighted Heating / Cooling Requests – Closed Loop

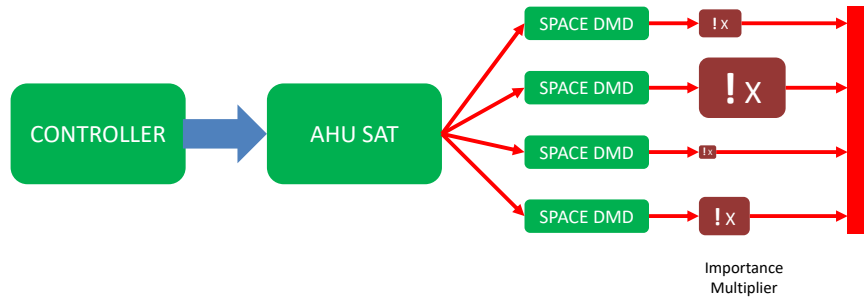

CXassociates<sup>llc</sup>

All the space temperature demands are multiplied by their importance multiplier. Those values are summed and...



# Guideline 36 vs Conventional

SAT Control – GL 36 – Weighted Heating / Cooling Requests – Closed Loop

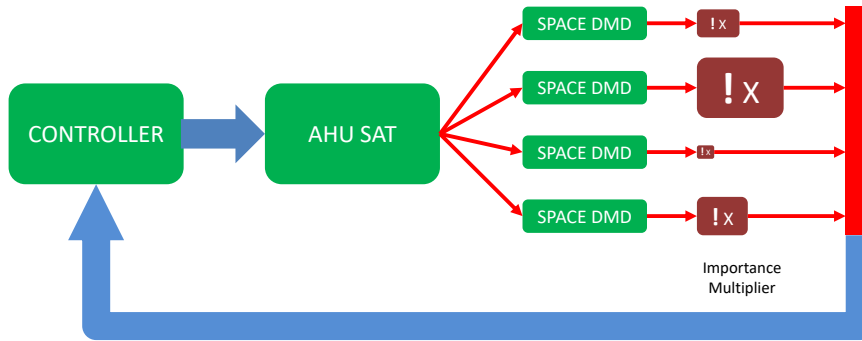

Cxassociates<sup>llc</sup>

Sent back to the controller where the SPACE DEMAND, not OAT, determines the supply air temperature.

## Importance Multiplier in Action

---

2.0	×	4	=	8.0
0.0	×	10	=	0.0
3.0	×	1	=	3.0
-1.0	×	3	=	-3.0

Space Demand      Importance Multiplier

CXassociates<sup>llc</sup>

The math can look like this (VERY exaggerated numbers to show the concept)

All the space temperature demands are multiplied by their importance multiplier. Those values are summed and...

## Importance Multiplier in Action

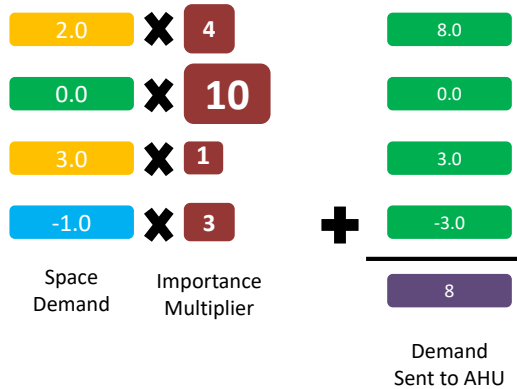

CXassociates<sup>llc</sup>

The total demand sent the AHU is determined to be 8.

There is also a time-based component that can be used here where request persisting more than an hour are also accumulated to increase their impact on the systems serving those zones.

Its called "Cumulative request hours"

<click>

## Importance Multiplier Quick Review

---

- **GL 36 uses an integer importance multiplier.**
  - Requires user / designer input
  - Allows for future modification
  - Can default to 1 for all zones at turnover
  - Request hours Accumulation (trend this to find rogue zones)

CXassociates<sup>llc</sup>

Here's a quick review of the importance multiplier.

There is a lot of information that flows back and forth between zones and equipment.

Lets look at the final example of this closed loop control.

The requests we just talked about are used in a sequence called "Trim and respond"

# Trim and Respond

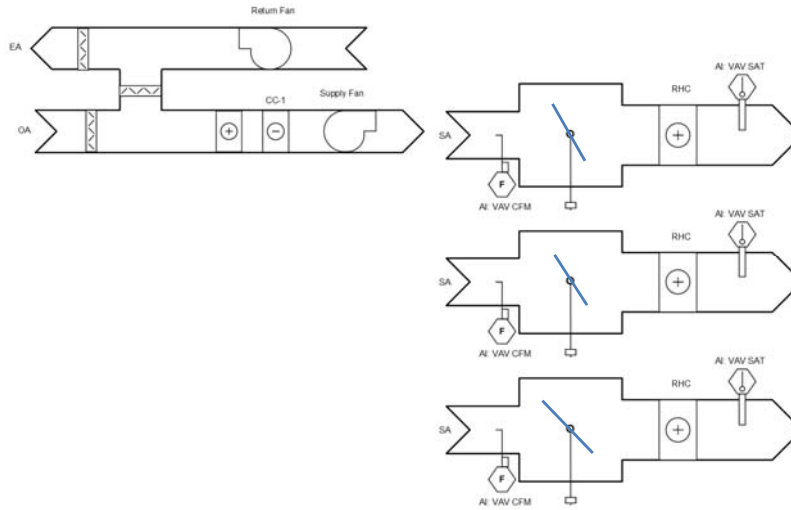

Cxassociates<sub>llc</sub>

So the idea is to constantly reduce the setpoint at a fixed rate until a downstream zone is no longer satisfied and generates a call for heating/cooling or airflow.

Lets look at airflow for out example

# Trim

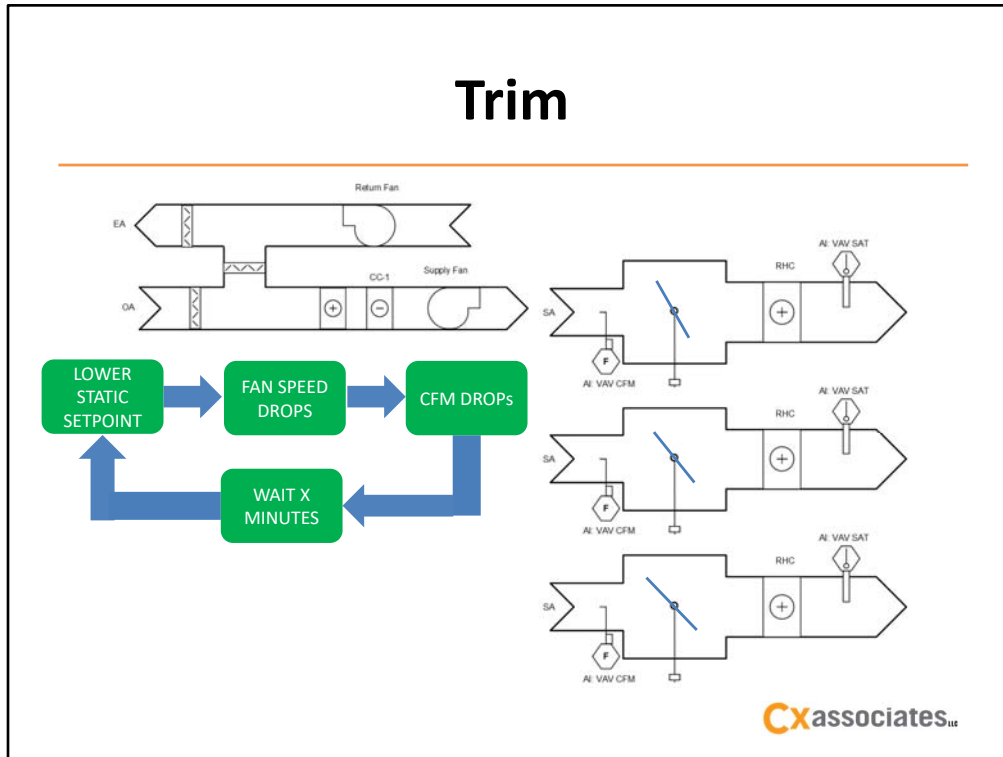

This is the Trim portion of Trim and respond.

It's the component that seeks to constantly lower the static pressure in the system. This creates fan energy savings.

The system can only trim to a point however, eventually there will be a down stream reaction.

# Trim

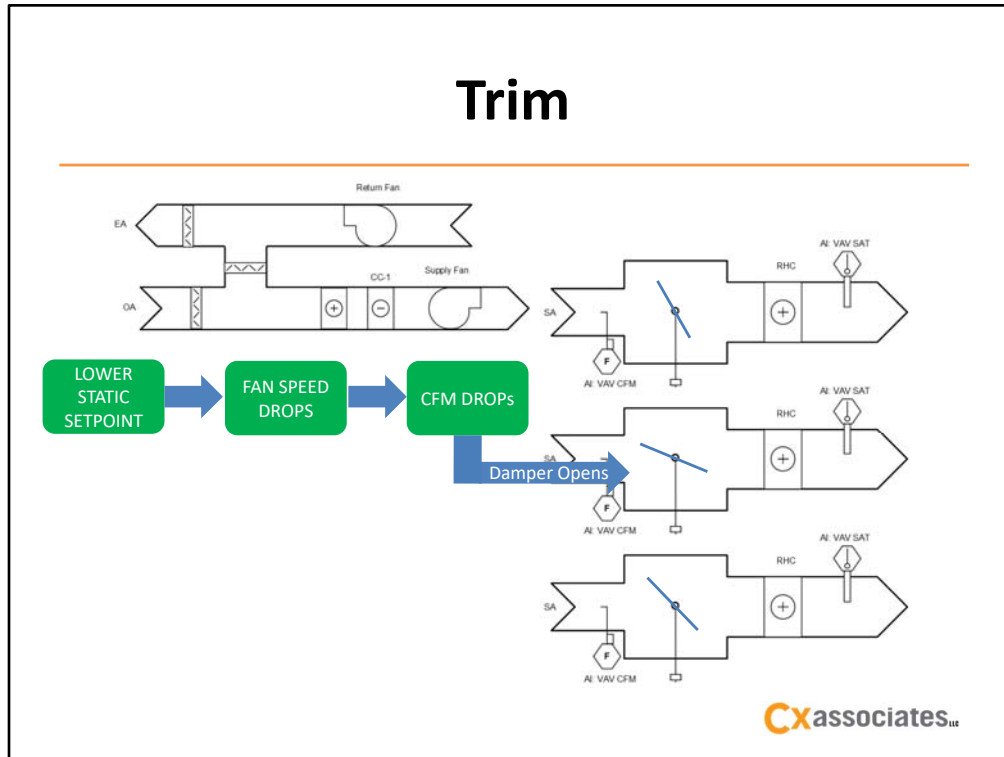

The damper crosses a positional threshold that the AHU looks for.

That VAV generates a Request for more static pressure.

# Trim

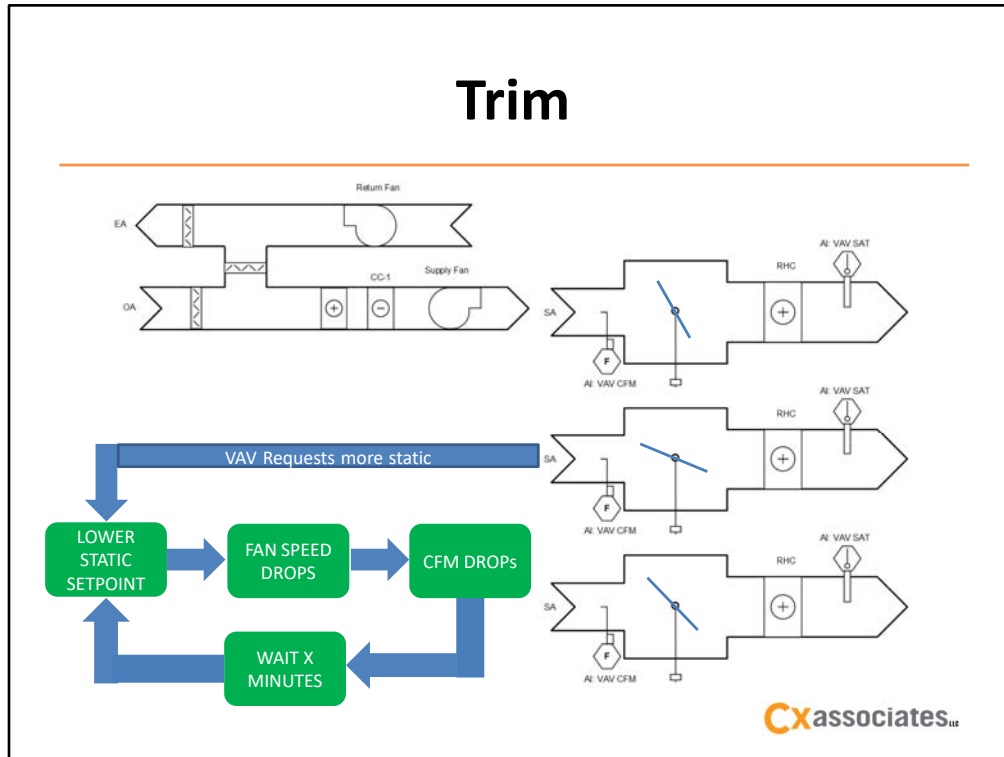

This request goes back to the AHU from the VAV (and is weighted via the importance multiplier).

Or rather the AHU controller polls the damper positions of all the VAVs and compares it to a value indicative of a "request" for more static.



# Trim to a point

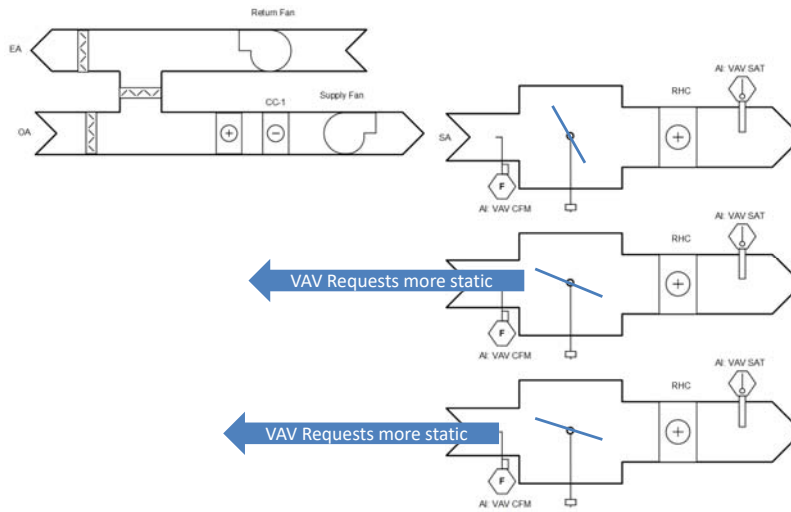

Cxassociates<sub>llc</sub>

**When enough dampers make this request (which is an adjustable value so you can cancel out the effect of rogue zones)**

# Respond

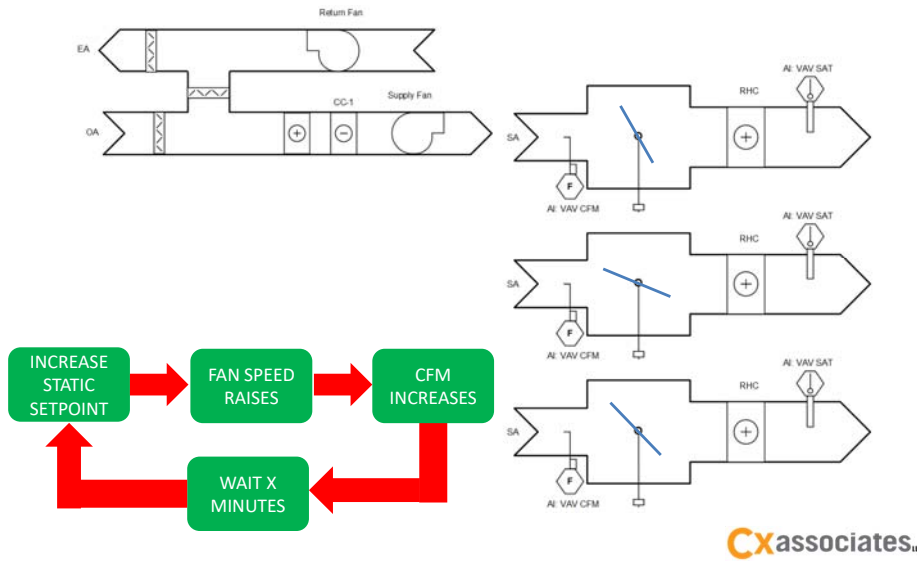

The system starts increasing static setpoint until the box requests are satisfied.

This is the "respond" portion of trim and respond.

# Trim and Respond

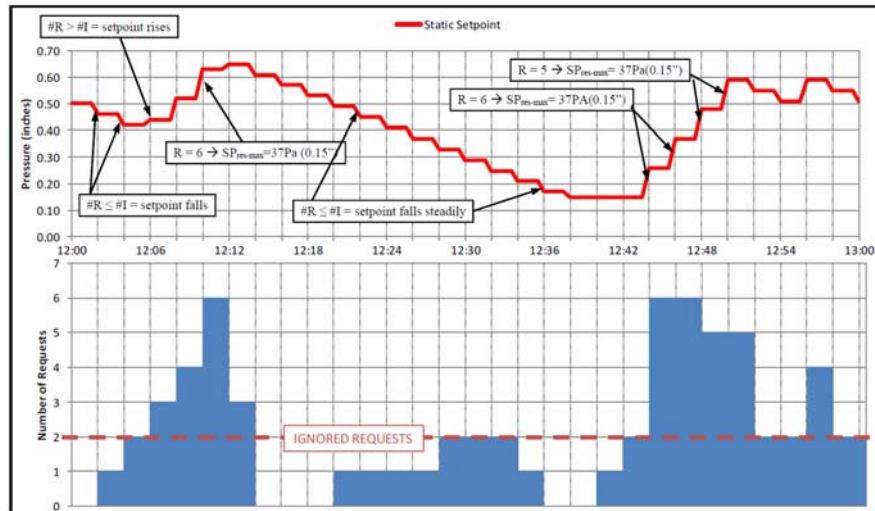

CXassociates LLC

The net result is a low frequency oscillation of the setpoint

that we can accept because it reduces fan energy

when properly tuned without affecting thermal comfort or indoor air quality.

You'll notice it spends most of the time decreasing the setpoint and responds rather quickly by design.

## From the Horse's Mouth

---

*Trim & Respond logic resets a setpoint for pressure, temperature, or other variables at an air handler or plant. It reduces the setpoint at a fixed rate, until a downstream zone is no longer satisfied and generates a request. When a sufficient number of requests are present, the setpoint is increased in response. The importance of each zone's requests can be adjusted to ensure that critical zones are always satisfied. When a sufficient number of requests no longer exist, the setpoint resumes decreasing at its fixed rate. A running total of the requests generated by each zone is kept to identify zones that are driving the reset logic.*

*Trim and Respond logic is optimal for controlling a single variable that is subject to the requirements of multiple downstream zones (such as the static pressure setpoint for a VAV air handler). In this application, it is easier to tune than a conventional control loop and provides for fast response without high frequency chatter or loss of control of the downstream devices. It typically does generate low frequency cyclic hunting, but this behavior is slow enough to be non-disruptive.*

*See the end of this section for an example of T&R implementation.*

CXassociates<sup>llc</sup>

**You can use this same approach for supply air temperature control**

**Valve position and differential pressure reset in hydronic systems**

**Any system with one fluid mover or heat exchanger serving many downstream connected loads can be considered for trim and respond logic by an experienced engineer.**

# Trim and Respond in Action!

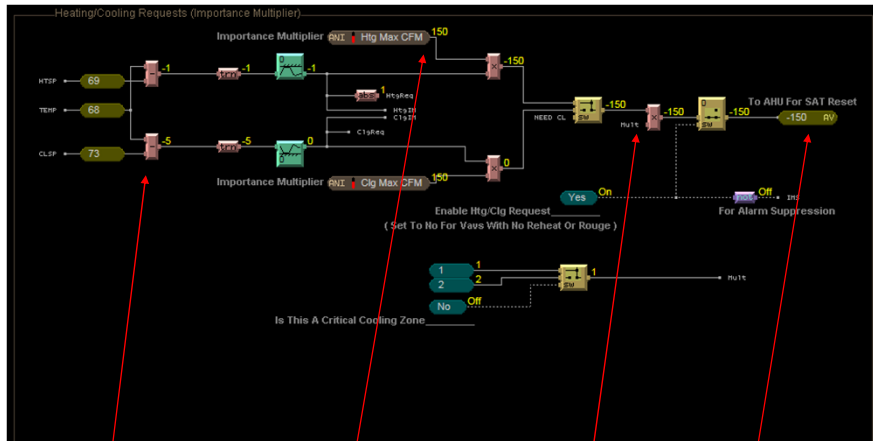

$$\begin{aligned}
 &(\text{space temp} - \text{space setpoint}) \\
 &\quad \times (\text{maximum heating CFM}) \\
 &\quad \times (\text{critical system multiplier}) \\
 &= \text{Heating Request to AHU}
 \end{aligned}$$

It reads like the equation above.

93

Here it is adapted for Fanny

# Trim and Respond in Action!

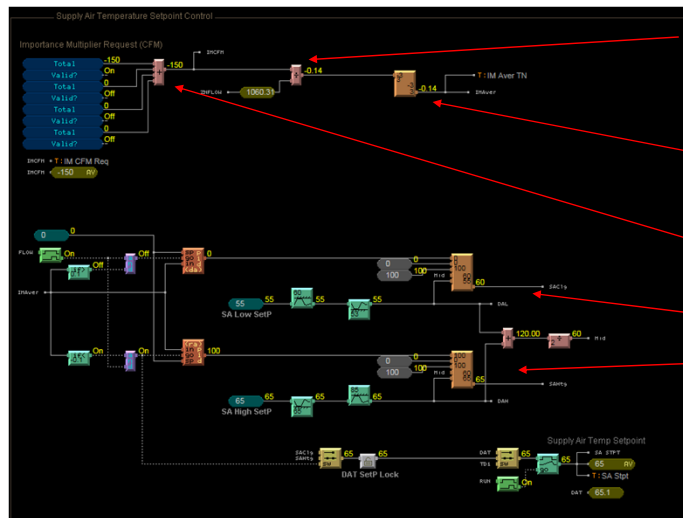

$(\text{Zone request}) / (\text{AHU SA CFM})$

Positive % call (cooling)  
Or  
Negative % call (heating)

We want "0" calls, meaning everyone is satisfied!

These PID's then adjust the AHU supply air temperature setpoint between 55 and 65 degrees F until all of the zone requests for heating and cooling are gone away ("0").

94

Here it is at the AHU level

Zone request / AHU SA CFM = 14% of the system served by this AHU needs more heating!

## Trim and Respond – Lot's O' Variables

Variable	Definition
$SP_0$	Initial setpoint
$SP_{min}$	Minimum setpoint
$SP_{max}$	Maximum setpoint
$T_d$	Delay timer
$T$	Time step
$I$	Number of ignored Requests
$R$	Number of Requests from zones/systems
$SP_{trim}$	Trim amount
$SP_{res}$	Respond amount (must be opposite in sign to $SP_{trim}$ )
$SP_{res-max}$	Maximum response per time interval (must be same sign as $SP_{res}$ )



CXassociates<sup>llc</sup>

HVAC systems are dynamic, but they are slow (lab hoods notwithstanding).

We don't want our AHU responding too quickly to requests just like we don't want our VAV box responding too quickly.

Both result in cycling or hunting and increase wear on components and result in poor space comfort or deficient air change rates.

Table is from GL 36 and lists all the variables that go into trim and respond. There is no calculus here, but there is more to it than just a 1 to 1 correspondence.

Trim and Respond, and closing the loops is applied to zone groups pretty heavily in Guideline 36 and at Fanny Allen.

The guideline provides instructions using the two basic zone types <next>

## GL36 Zone Types

---

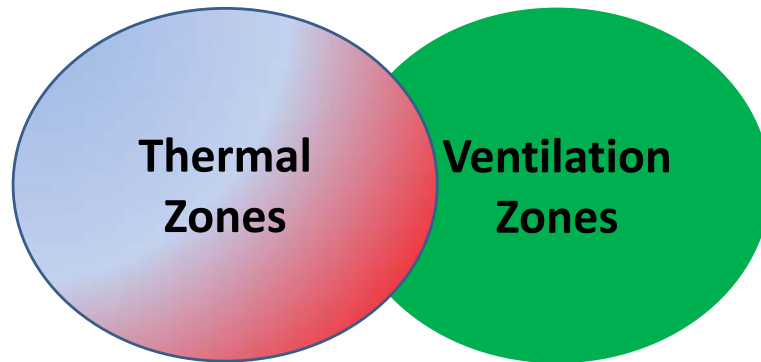

96

CXassociates<sup>llc</sup>

**The guideline addresses thermal zones and ventilation zones directly.**

**Some Ventilation zones may share a thermal zone (think perimeter Fin Tube Radiation crossing zones with different VAVs)**

**Some Thermal zones may share the same ventilation zone.**

**Guideline 36 separates these two control strategies and provide guidance on both in terms of how they send signals up the hierarchy to close the control loop.**



# Fanny Allen Zone Grouping

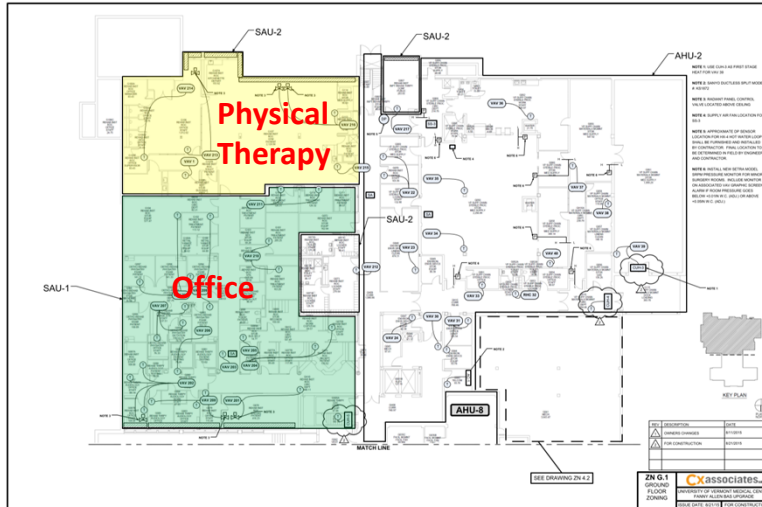

Here you can see two different zone groups at Fanny with very different purposes.

They will have different occupancy rates, different temperature requirements, and different ventilation rates.

# Fanny Allen Design Phase Process

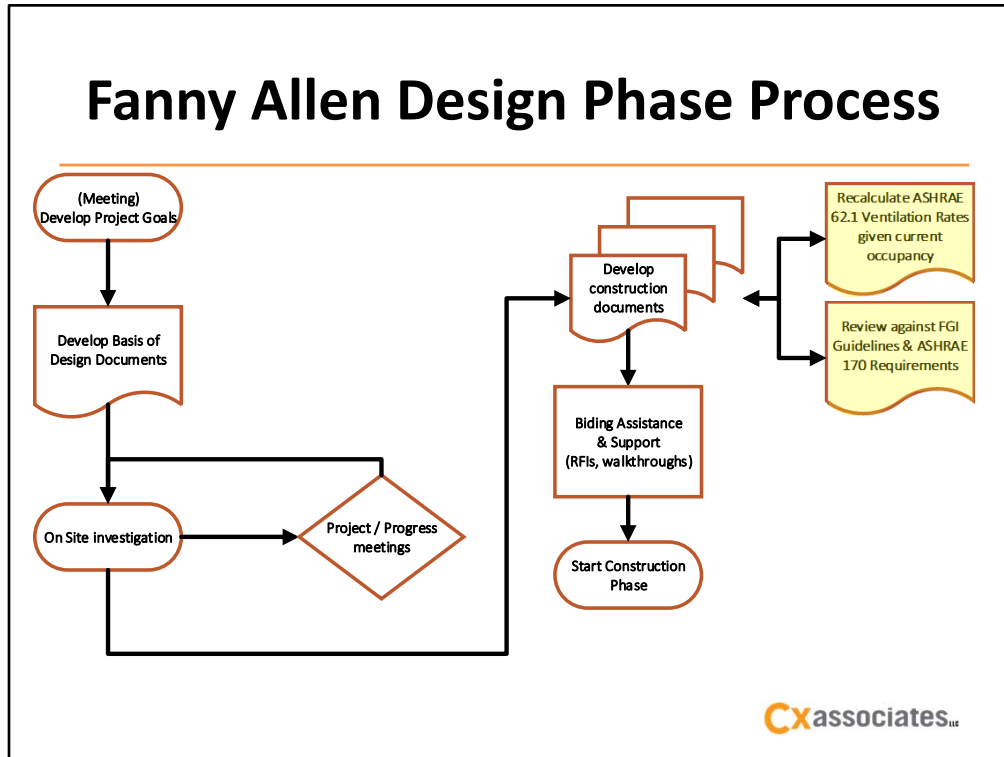

So while performing our survey we saw the opportunity to update the control of these zones.

We recalculated the ventilation rates to conform with the current space use, and occupancy.

Of course to do this we had to refer to ...  
<click>

# Fanny Allen Design Ventilation Recalculation

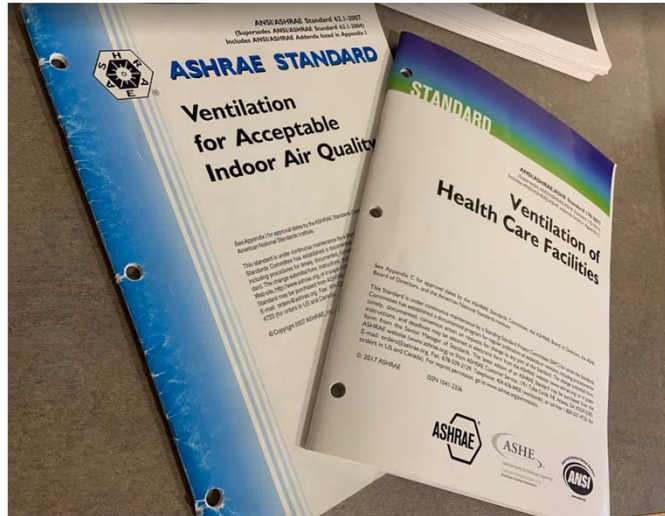

CXassociates LLC

**ASHRAE 170 and 62.1 ventilation standards.**

**Its rare in our industry to do a whole-building recalculation of these values.**

**Again, this was time intensive.**

# Fanny Allen As-Built Development

The image displays a detailed technical drawing titled "AIR FLOW SCHEDULE" for the Fanny Allen As-Built Development. It consists of several tables and notes:

- AIR FLOW SCHEDULE (Top Left):** A large table with columns for Room No., Room Name, and Air Flow (CFM).
- AIR FLOW SCHEDULE (Middle Left):** A table with columns for Room No., Room Name, and Air Flow (CFM).
- AIR FLOW SCHEDULE (Top Right):** A table with columns for Room No., Room Name, and Air Flow (CFM).
- NOTES:** Several numbered notes providing specific instructions and clarifications regarding the air flow data and construction requirements.
- LEGEND:** A small table defining symbols used in the drawing, such as Room No., Room Name, and Air Flow (CFM).
- EXPLANATION:** A section at the bottom right providing further details and instructions.

But in the end, UVMCC received a comprehensive inventory of all their Variable Air Volume controllers (VAVs) and a schedule of updated air flow values which would be used later on in the project to air balance the entire building.

# Guideline 36 Overview and Systems

## A. VAV Terminal Unit, - Cooling Only

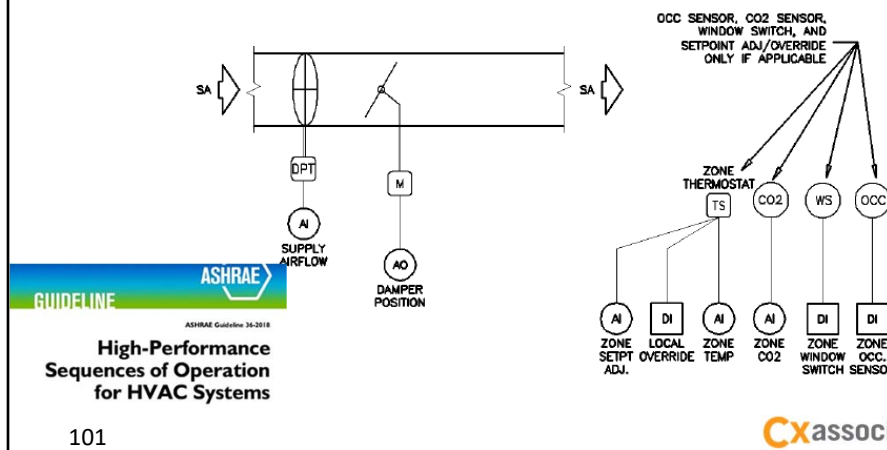

This also gave us a chance to figure out what types of VAVs and other terminal unit equipment we had to work with.

The guideline currently only provides air side systems sequences.

It provides point layouts for each system covered. <click>

Image Source: GPC36 PPR1 05-16-2016

# Terminal Units Covered

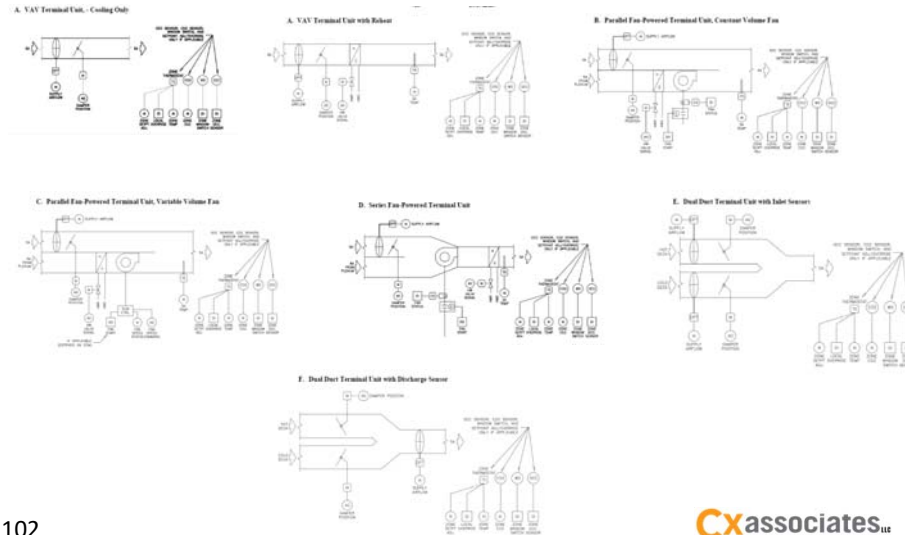

This is really nice because this allows both designers and implementers to standardize their layouts on each job.

You will always know what is expected and common hardware for your application.

The Guideline Covers

- A) VAV – Cooling only
- B) VAV with reheat
- C) Fan Powered Terminal Unit (Series or parallel, Constant or variable speed fan)
- D) Dual Duct Terminal unit with inlet sensors
- E) Dual Duct Terminal Unit with discharge sensor

They are currently in the process of developing plant sequences.

Fanny had a majority of VAVs with reheat and Fan Coil units for inpatient spaces.

Image Source: GPC36 PPR1 05-16-2016

Rick

## Zone Control

---

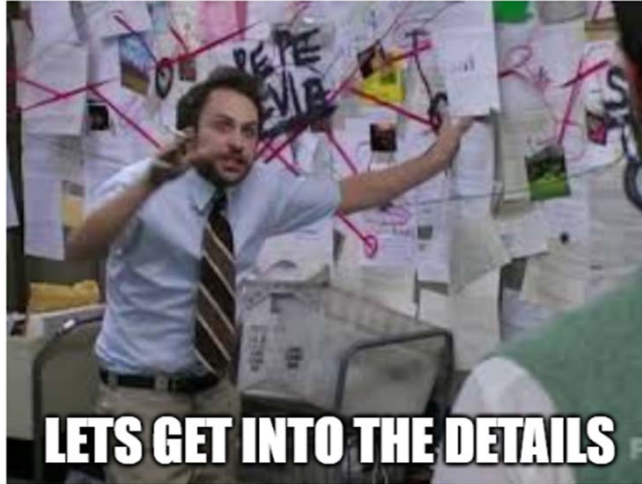

CXassociates<sup>llc</sup>

Lets talk a bit about Guideline 36's Zone Control Details.

# Conventional

PART 2 PRODUCTS - NOT USED

PART 3 EXECUTION

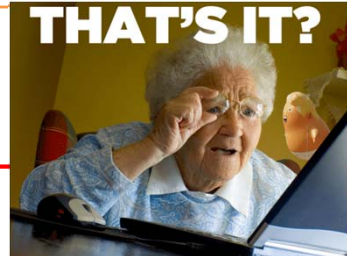

## 3.1 AIR TERMINAL UNITS

### A. Single-duct Variable Volume:

#### 1. Cooling with Reheat:

- a. On a rise in space temperature above the cooling set-point, the unit modulates to its maximum airflow.
- b. As the space temperature falls below the cooling set-point, the unit modulates to its minimum airflow.
- c. As the space temperature continues to fall to the heating set-point, the terminal modulates to its heating minimum airflow.

## 3.2 CHILLED WATER SYSTEM

- A The chilled water system consists of an existing air source chiller relocated to the roof with an

104

CXassociates<sup>inc</sup>

This is what I've seen for VAVs as a commissioning agent. I have seen sequences this simple from several design firms.

### Note:

- All control is based on deviation of space temperature from setpoint by some undefined amount.
- It implies a proportional deviation, but they could also be implying a type of differential control (Thermostatic) for the cooling side.
- Although they make use of a minimum heating airflow, they do not give direction as to when to use the reheat and how to use reheat.
- This leaves a lot in the hands of the control's contractor.
- Not that they can't handle it, but there is a diverse amount of experience within a controls company and you might not always end up with the veteran on your project.

Graphed, this sequence looks like this <click>



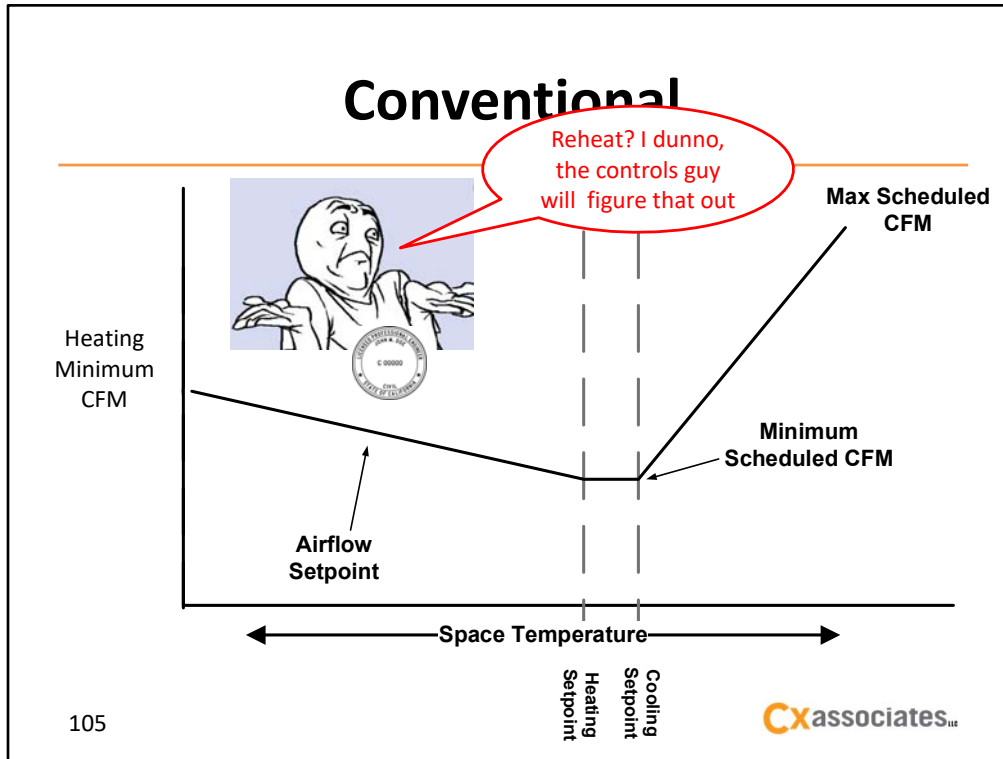

**They didn't own their building system's energy usage.**

**Notice that didn't direct the controls contractor on how the reheat is to be controlled**  
<click>

**leaving it up to interpretation (or just do what you always do).**

# GL36 VAV with Reheat

## 5.6 VAV Terminal Unit with Reheat

**5.6.1** See "Generic Thermal Zones" (Section 5.3) for set points, loops, control modes, alarms, etc.

**5.6.2** See "Generic Ventilation Zones" (Section 5.2) for calculation of zone minimum outdoor airflow.

**5.6.3** See Section 3.1.2.2 for zone minimum airflow set point  $V_{min}$ , zone maximum cooling airflow set point  $V_{cool-max}$ , zone maximum heating design airflow set point  $V_{heat-max}$ , and the maximum DAT rise above heating set point  $Max\Delta T$ .

**5.6.4** Active maximum and minimum set points shall vary depending on the mode of the zone group the zone is a part of (see Table 5.6.4).

*These sequences use different maximum airflow set points for heating and cooling. This dual-max logic allows the minimum airflow set point to be lower than in a conventional sequence where the minimum airflow equals the heating airflow.*

*Heating is nonzero in cooldown to allow for individual zones within a zone group that may need heating while the zone group is in cooldown.*

*The warm-up and setback minimum set point is set to zero to ensure spaces that do not want heat during these modes receive no air; because the supply air temperature can be warm in these modes if the AHU has a heating coil, any minimum could cause overheating. The heating minimum is set to*

- a. If supply air temperature from the air handler is greater than room temperature, cooling supply airflow set point shall be no higher than the minimum.

**5.6.5.2** When the zone state is deadband, the active airflow set point shall be the minimum airflow set point. Heating coil is disabled unless the DAT is below the minimum set point (see Section 5.6.5.4).

106

state is heating, the heating loop setpoint at the heating set point as

ing heating sequence is to minimize reheat by first increasing the SAT in flow, and only increasing the reheat if the zone.

heating-loop output shall reset the setpoint from the current AHU setpoint to  $Max\Delta T$  above space temperature set point shall be the

max to for the heating-loop output shall reset the minimum airflow setpoint to the heating airflow set point.

Figure 5.6.4 shows the logic for the heating-loop output.

Figure 5.6.4 shows the logic for the heating-loop output. The heating-loop output is set to zero when the zone is in a heating mode and the supply air temperature is greater than the room temperature. The heating-loop output is set to the minimum airflow setpoint when the zone is in a heating mode and the supply air temperature is less than the room temperature.

- a. If supply air temperature from the air handler is greater than room temperature, cooling supply airflow set point shall be no higher than the minimum.

**5.6.5.2** When the zone state is deadband, the active airflow set point shall be the minimum airflow set point. Heating coil is disabled unless the DAT is below the minimum set point (see Section 5.6.5.4).

**5.6.7 Testing/Commissioning Overrides.** Provide soft-

the CxA can check for leaking dampers by closing a zone group closed and then recording the AHU. If the sequences are not part of the initial scope but control logic for plant requests are being used, when central plant sequences are used, the heating hot-water plant will start when one request for 5 minutes, and stop when one request for 5 minutes, after a minimum run-time of 5 minutes.

reset requests are used in T&R loops to control temperature and/or pump DP set points based on AHU demands.

**Reset Requests**  
**Heating SAT Reset Requests**

temperature exceeds the zone's cooling setpoint (5°F) for 2 minutes and after suppression of setpoint change per Section 5.1.19, send 3 requests.

one temperature exceeds the zone's cooling setpoint (3°F) for 2 minutes and after suppression of setpoint change per Section 5.1.19, send 2 requests.

cooling loop is greater than 95%, send 1 request. If the cooling loop is less than 85%, send 1 request.

**Pressure Reset Requests**

supply airflow is less than 50% of setpoint while the damper position is less than 95% for 1 minute, send 3 requests.

measured airflow is less than 70% of setpoint while the damper position is less than 95% for 1 minute, send 2 requests. If the damper position is greater than 95%, send 1 request. If the damper position is less than 85%, send 0 requests.

**Reset Requests**  
**Hot-Water Coil, Hot-Water Reset**

supply airflow is less than 50% of setpoint while the damper position is less than 95% for 1 minute, send 3 requests.

# Deviation from Conventional

## 5. Control Loops

- a. Two separate control loops shall operate to maintain space temperature at setpoint, the Cooling Loop and the Heating Loop.
  - 1) The Heating Loop shall be enabled whenever the space temperature is below the current zone heating setpoint temperature, and disabled when space temperature is above the current zone heating setpoint temperature and the Loop output is zero for 30 seconds. The Loop may remain active at all times if provisions are made to minimize integral windup.
  - 2) The Cooling Loop shall be enabled whenever the space temperature is above the current zone cooling setpoint temperature, and disabled when space temperature is below the current zone cooling setpoint temperature and the Loop output is zero for 30 seconds. The Loop may remain active at all times if provisions are made to minimize integral windup.
- b. The Cooling Loop shall maintain the space temperature at the active cooling setpoint. The output of the loop shall be a software point ranging from 0% (full cooling) to 100% (full heating).
- c. The Heating Loop shall maintain the space temperature at the active heating setpoint. The output of the loop shall be a software point ranging from 0% (full heating) to 100% (full cooling).



ASHRAE Guideline 36-2018

**High-Performance  
Sequences of Operation  
for HVAC Systems**



107

CXassociates LLC

## Under Guideline 36

**Each zone is required to have two separate PIDs controlling the space temperature! One for heating and one for cooling!**

**This tends to be a shocker <CLICK> for some who are very comfortable with the “keep it simple approach”**

**There is a benefit to this!**

- **Your cooling response isn't the same proportionally as your heating response**
- **You can tune your cooling control differently from the tuning of your heating control (because you have two PIDs!) on a space by space level.**
- **PIDS create a demand signal based on a proportional deviation but they also respond to how long you've maintained that deviation!**
- **You respond to heating and cooling DEMAND,**

**Some of you might be thinking “How do you prevent the two loops from battling for control of the space?”**

<next>

## Deviation from Conventional

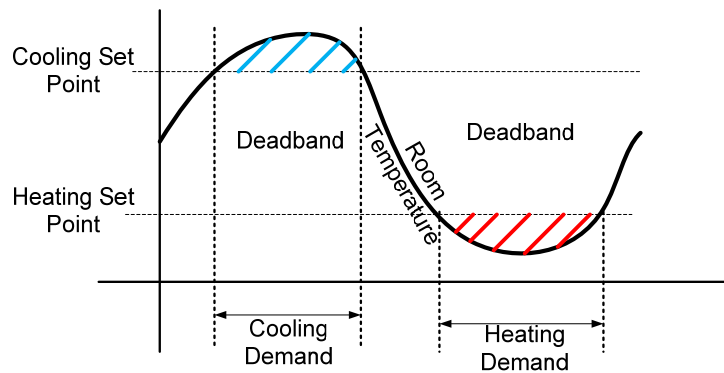

108

CXassociates<sup>llc</sup>

**The Guideline specifies when you enable / disable the loops to prevent a tug of war.**

**They're only enabled when the space temperature floats outside the dead band as shown in the colored areas here.**

**This is important because your control product has to allow for a programmer to stop a loop from calculating or winding up.**

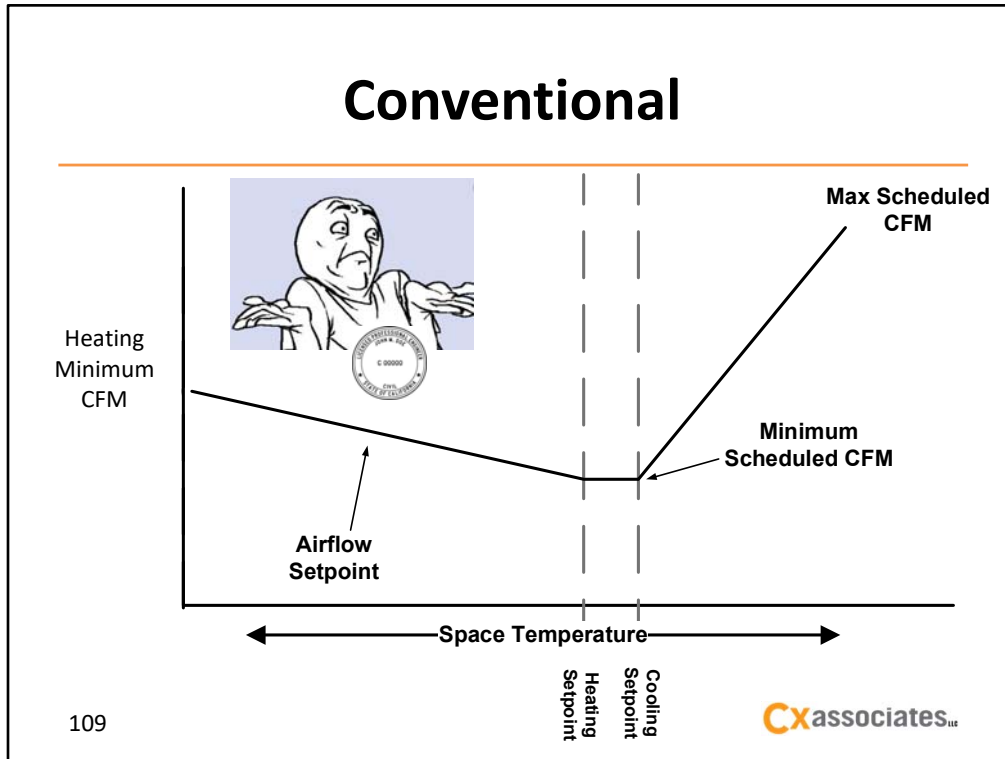

So remember this sequence?

This is what it looks like with Guideline 36: <click>

# The Guideline 36 Method

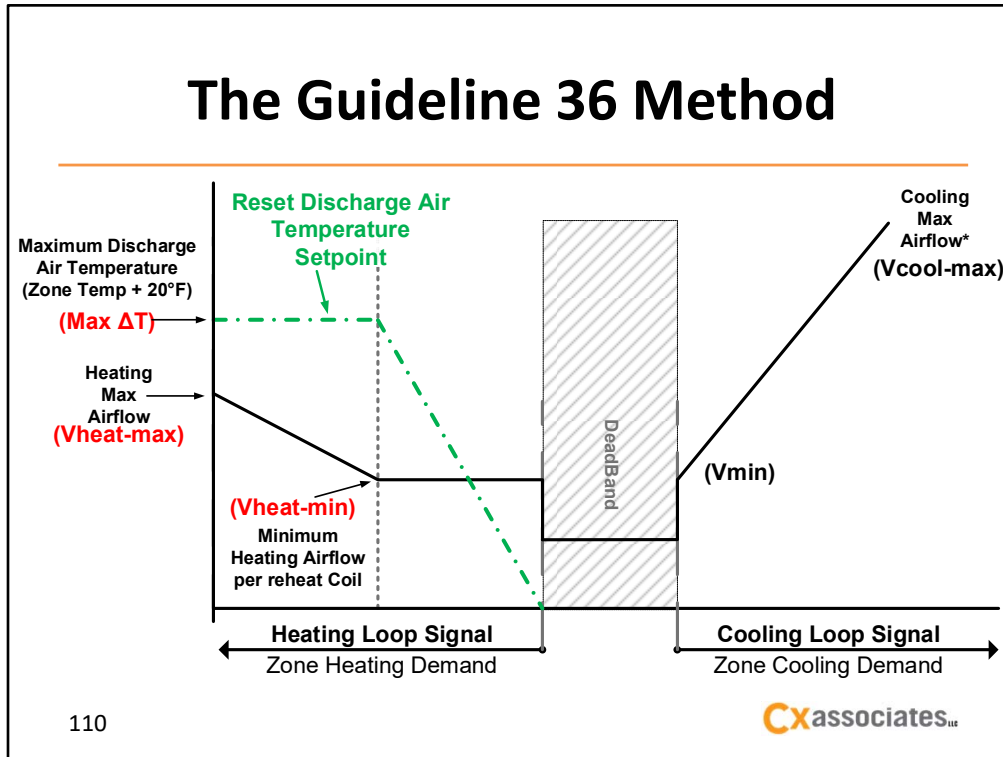

So you can see that the x axis has changed to be two arrows going away from deadband. This represents the percentage output of each of two required PIDs.

Notice that green part of the sequence calling for a calculated discharge air setpoint (called a reset setpoint in industry parlance).

<next>

## GL 36

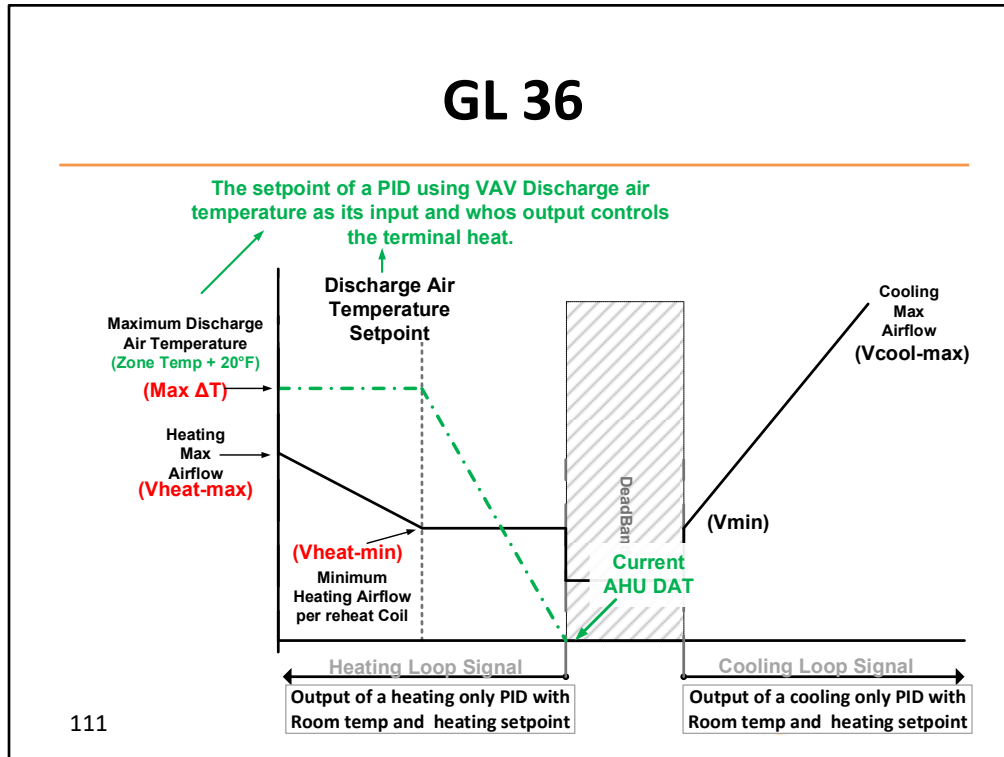

One other cool caveat in the sequence is that if the AHU DAT is greater than room temperature, the cooling supply air setpoint is locked at minimum.

Also the guideline prescribes cascading PIDs.

That's to say that the output of the zone heating PID feeds an input of another PID.

The output of the zone heating demand is scaled to calculate the discharge air temperature setpoint.

That setpoint is used by the heating control valve PID to maintain DAT out of the box at the reset DAT setpoint.

The calculated DAT setpoint is dynamically limited in its range.

The lowest DAT the box can achieve is current AHU DAT.

The maximum DAT value is based on maintaining ventilation distribution effectiveness.

What do I mean by that?

In ceiling supply and return the VAV max DAT is locked to space temperature +20 degrees so that you do not have to bring in more fresh air from the AHU (as called for by ASHRAE



**62.1).**

**So right off, you can see that the guideline requires at least 3 PIDs for temperature control.**

**This really minimizes the use of terminal heating across every VAV in your system.**

# Deviation from Conventional

## 4.2 VAV Terminal Unit with Reheat

Re-quired ?	Description	Type	Device
R	VAV Box Damper Position	AO <b>OR</b> two DOs	Modulating actuator <b>OR</b> Floating actuator
R	Heating Signal	AO <b>OR</b> two DOs	Modulating valve <b>OR</b> Floating actuator <b>OR</b> Modulating electric heating coil
R	Discharge Airflow	AI	Differential pressure transducer connected to flow sensor
<b>R</b>	Discharge Air Temperature	AI	Duct temperature sensor (probe or averaging at designer's discretion)
R	Zone Temperature	AI	Room temperature sensor
A	Local Override (if applicable)	DI	Zone thermostat override switch
A	Occupancy Sensor (if applicable)	DI	Occupancy sensor
A	Window Switch (if applicable)	DI	Window switch
A	Zone Temperature Setpoint Adjustment (if applicable)	AI	Zone thermostat adjustment
A	Zone CO <sub>2</sub> Level (if applicable)	AI	Room CO <sub>2</sub> sensor

112

Associates, Inc.

You can also see that the Supply Air temperature sensor is mandatory.

This one low cost sensor provides a lot of value within your control system.

## “Logic is the beginning, not the end, of Wisdom.” - Spock

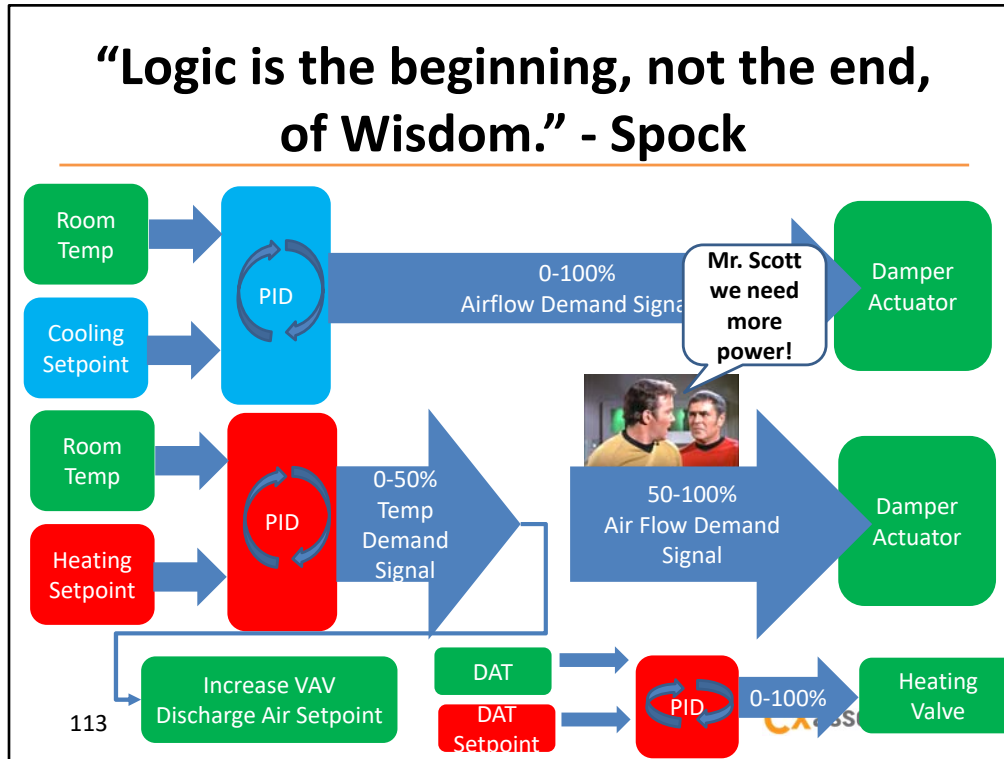

The cooling PID, on a call for cooling is activated and drives the VAV from min cooling flow (or min flow) to max flow.

The heating PID on a call for heating

First stage (50% of PID output) increases the DAT setpoint which

Drives the heating valve open without changing flow

Then on a call for more heating (as the PID winds up more) <click>

The VAV modulates the damper open to heating max air flow (which is different from Cooling Max Flow).

Image Source:

<https://jameskillough.files.wordpress.com/2012/04/scotty.jpg>

Rick

# A New Way of Thinking about VAVs

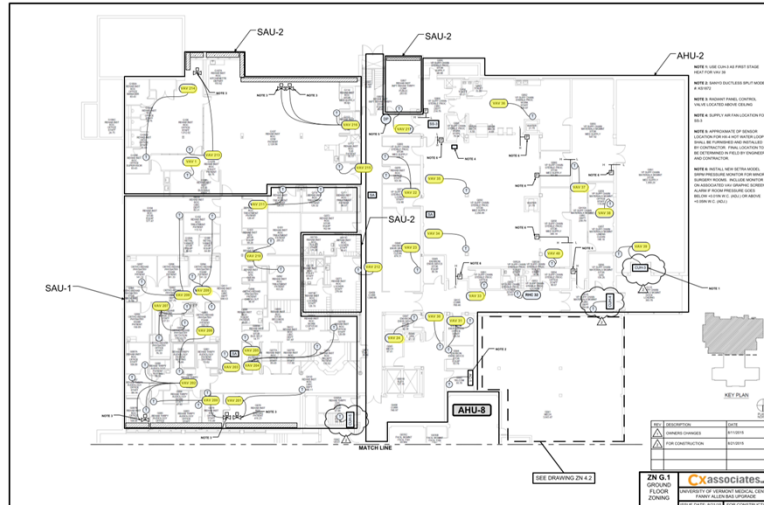

So now all this logic is packed into each of the these VAVs.

And this is only half of one floor of the building.

Each VAV is looking to minimize air flow and minimize reheat energy by responding to demands.

Each VAV can be fine tuned to uniquely address its space's needs.

And each VAV is affecting the air handler by making requests for heating/cooling changes in static pressure.

So to recap:

## Recap - After Dealing With Design

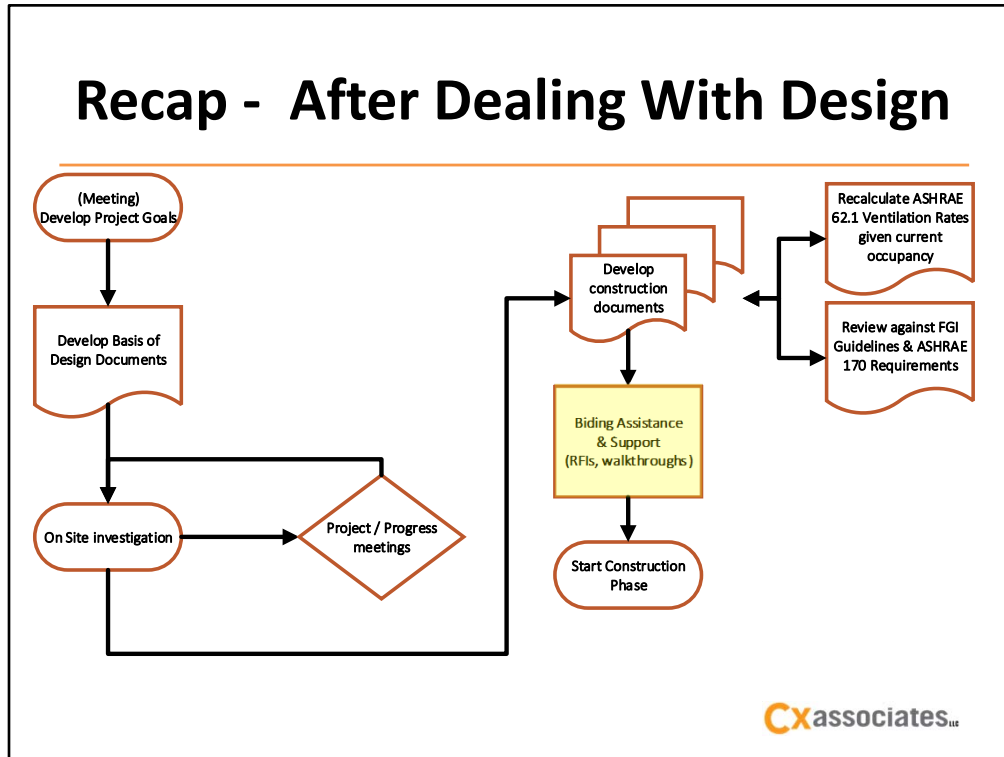

We had put this work into the design.

We had made the set of drawings and recalculated the air flows.

We developed a comprehensive spec for Fanny to use for bidding.

Then CxA assisted in contractor selection by providing bidding assistance.

## Fanny Allen BAS Bidding Assistance

---



CXassociates<sup>llc</sup>

The team solicited bids from 4x companies in the area. And tested each of their skill/abilities

...

## Fanny Allen BAS Bidding Assistance

---



CXassociates<sup>llc</sup>

With an interview,

# Fanny Allen BAS Bidding Assistance

Category	#	Question
Company Background & History	1	How long have you been in business doing controls work?
Company Background & History	2	What types of projects do you s Describe your experience with c the University of Vermont Med 3 5 years).
Company Background & History	4	Where is your local shop/office.
Company Background & History	5	How do you stay up to date on c Do you stay up to date on any o 6 to date?
Company Background & History	7	Where do you see the controls i
Project Related	1	Describe other projects like this
Project Related	2	Who would be assigned the sup
Project Related	3	What is your warranty?
Project Related	4	How many projects do you curr
Project Related	5	Please describe in detail your pi
Project Related	6	Explain a time when you have had to work with a customer to find a creative solution to a problem to avoid 6 or minimize cost overrun.
Project Related	7	What approach do you take when a customer requests something that was not spec'd in the design?
Maintenance and Support	1	Please describe in detail your proposed maintenance contract for a project like this? What does your on hand inventory of replacement parts look like right now? What is your method for
Maintenance and Support	2	stocking repair parts?
Maintenance and Support	3	How many staff do you have locally that can perform troubleshooting and repair work? What does your 3 organizational structure look like?
Maintenance and Support	4	How do you staff your 24/7 service team? How can they be reached off hours?
Maintenance and Support	5	What other customers do you support in this area?
Maintenance and Support	6	Labor rates.
Maintenance and Support	7	Typical service contract structure.
Maintenance and Support	8	What outside resources do you use to assist with your maintenance work. i.e. specific electrical 8 contractors, Mechanical contractors, etc.
Maintenance and Support	9	What is your experience with constant commissioning software like Skyspark?

CXassociates LLC

**We setup a matrix of questions and answers and had the Fanny staff record answers along with our engineering staff.**

These interviews dove into the following areas:

1. Understanding their experience in healthcare
2. Understanding their experience with controls retrofits (this was NOT new construction)
3. Experience with SkySpark, a product chosen by UVMCC to perform fault detection diagnostics
4. Future maintenance options (service contract) after the project is complete

**we also had to factor in product.**

**At that time we knew 2 of the 4 contractors would likely install a tridium system.**

**Tridium was at the end of a product life cycle.**



## Product Issues



Every control system out there is released in a generational progression the same way smart phones are released.

If you know you need to replace your phone, but in 2 months the next phone will come out for the same price what do you do?

This is important to consider with BAS systems since they have a generational life cycle of about 10 – 15 years depending on the manufacturer.

Meaning if you buy the BAS 2 years before the newest one comes out – you essentially purchasing a brand new, OLD system.

# Life Cycle of BAS products



15 years

CXassociates LLC

This graph is entirely made from my experience.

However I think a lot of controls folks would agree that this is on average the way a product's life cycle goes over a course of 15 to 20 years

# Awareness of Current Industry Products

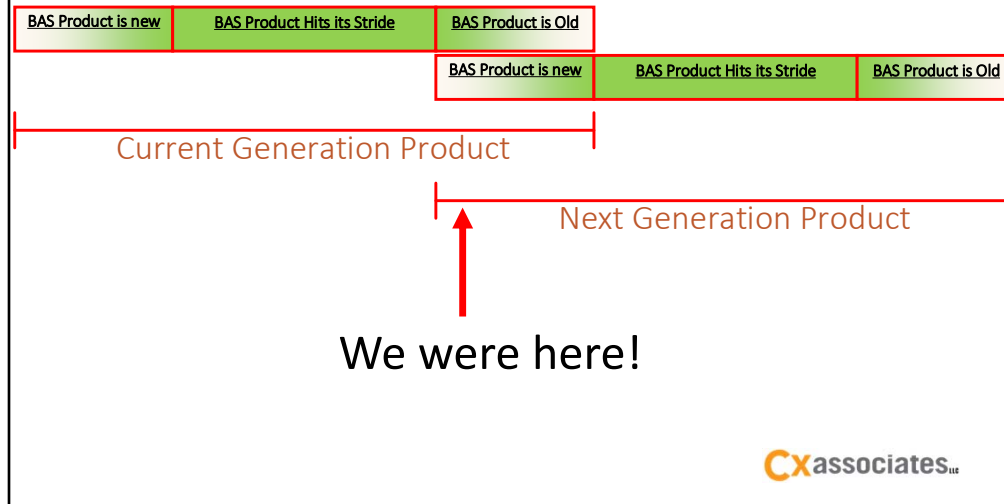

We were here with Tridium systems. We knew the old Ax Software was at the end of its product life and they were going to release the next generation products (Niagara 4) the same year the upgrade occurred.

We asked our bidders about how they would handle this and worked some caveats about this into the specification to ensure Fanny wouldn't receive a brand new "old product".

# Bidding Success!



Each contractor provided their bid after the project walk throughs and interviews

They bid on our 26 page BAS controls design drawing set including 11 pages of floor plans, MEP equipment locations, zone data, and a comprehensive updated as-built schedule of VAVs with new ventilation rates.

We had developed a 174 page specification that avoided boiler plate nonsense

Then the bids came in.

## Fanny Allen BAS Pricing

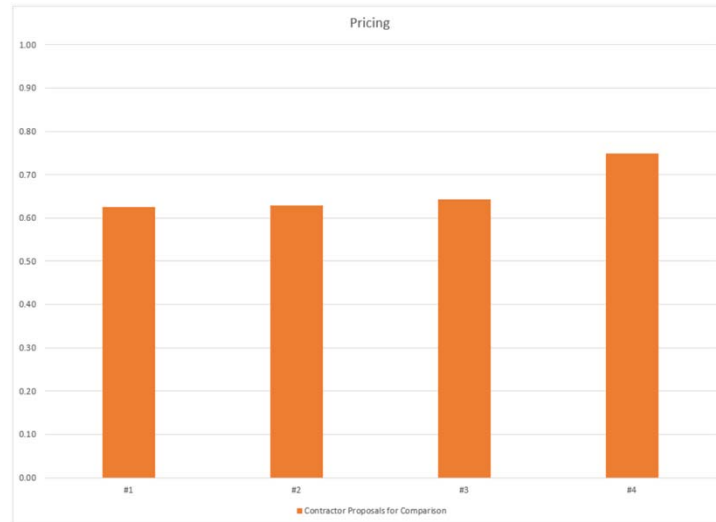

CXassociates LLC

- These are not the actual numbers of course, this is normalized to abstract the pricing. However it shows on a percentage basis how close the bids were to one another.
- In the end, UVMCM made a chose based on criteria other than lowest first cost.
- The hard work and time spent developing the specification, and really doing the homework on site paid off.
- The #4 knew the building really well which is why their cost was higher!!!
- Anyone in the industry can suffer from having too much knowledge!

## Support From Efficiency Vermont

---



CXassociates<sup>llc</sup>

- At this point, the team was working with Efficiency Vermont to establish energy efficiency incentives for the project.

## Support For Third Party Cx

---



Cxassociates<sup>llc</sup>

- They provided support for commissioning

## Metering to capture impact

---

Pre →



Post →



## Measurement and Verification

**CX**associates<sup>llc</sup>

- They supported the measurement and verification and created a performance-based incentive.
- Their support really helped with this project.



# Fanny Allen Construction Begins

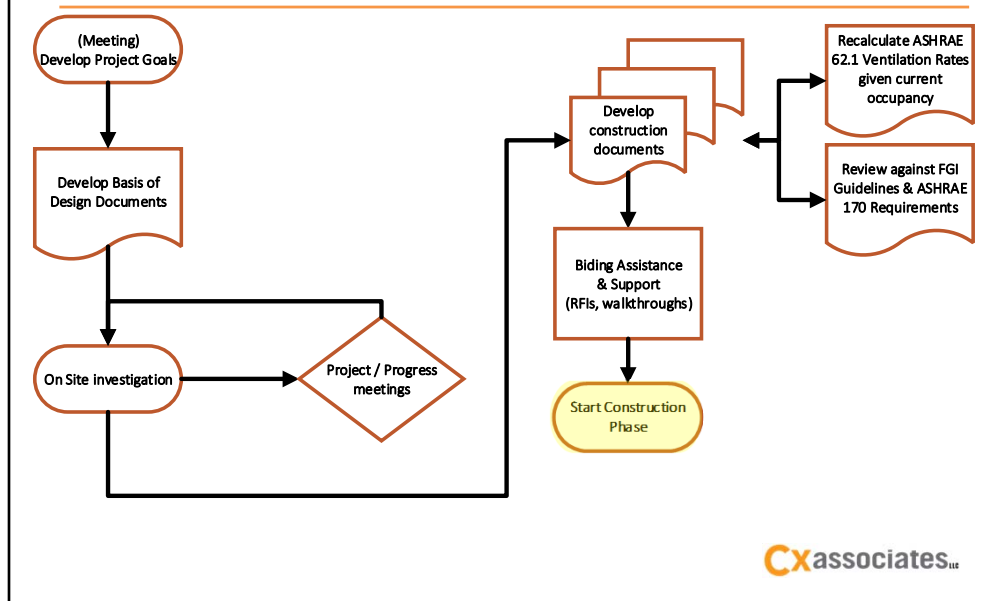

The bid was selected and construction started.

# Temperature Controls of Vermont

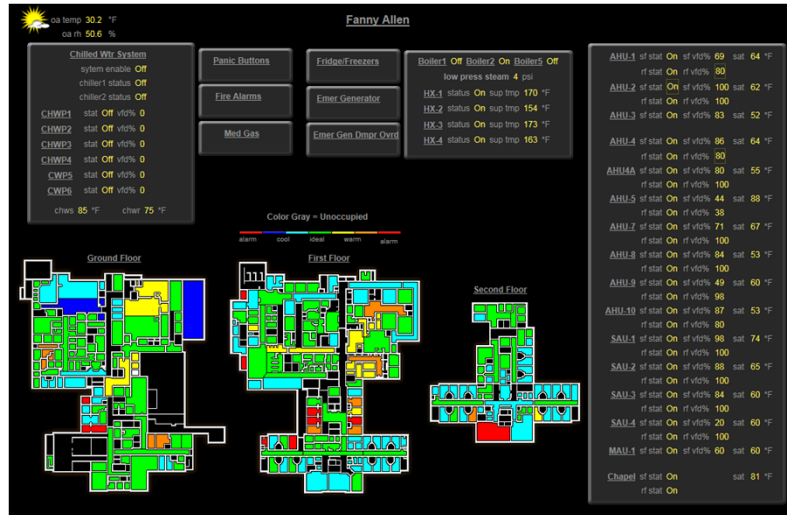

128

TCV won the contract and was brought into the team.

# Healthcare Risk Assessment

---



- **Affects every area of hospital**
- Coordination with:
  - Health and Safety Department
  - Infection Prevention Department
- Approach for mitigating issues:
  - Off-hours work
  - Follow protocol for sensitive areas
  - Proper clean-up
  - Communication with key staff members

129

1. Most, if not all work was completed off-hours when the majority of occupants were not there.
2. In critical areas (operating rooms and patient rooms), a glove-bag approach (similar to what is done with asbestos removal) was used for installing new thermostats, which requires cutting into sheetrock walls. This method helped with containing all debris and material in the bag.
3. Proper cleaning by our environmental services group was coordinated before the room/space was turned back over to the staff.
4. Because it was off-hours work, it was important to communicate when work would occur with key staff members.

# Off-Hours Schedule

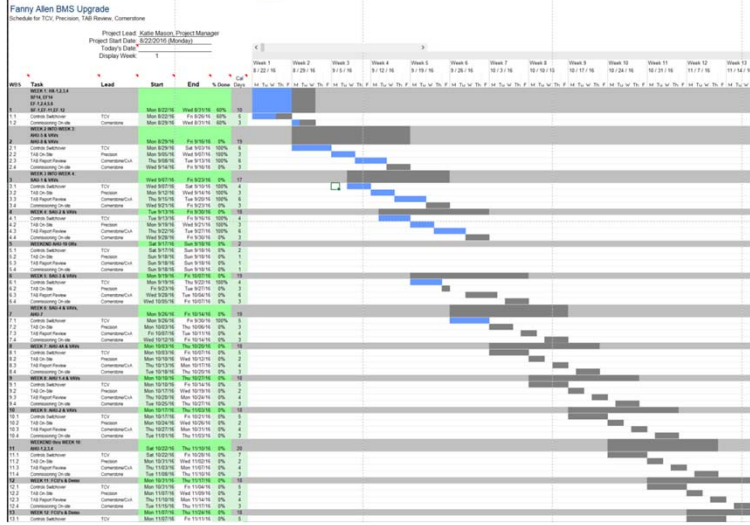

130

1. The schedule was phased, and each week the TCV team would check in with the Fanny Team.
  1. There was a deep level of involvement
1. Because of this effort – the hospital never shut down.

# Education

---

Customers



Maintenance Staff



131

Lots of work was done for in house management of expectations. Everybody knows when a big upgrade is happening, even if controls are not the most visible type of work in a building.

# Education

---

## Customers



- Set Expectations
- Prioritize Training
- Tailor Notification Methods

132

The Maintenance group worked hard to control expectations and have contingency plans in place should something go wrong.

# Education

---

## Maintenance Staff

- Phased Training
- Keep it Relevant
- Repetition



133

It took a lot of relevant phased training and repetition to raise all ships in the harbor regarding the new way of operating and how to handle the upgrade as systems came online.

Operators had to learn the new sequences, the new interface, and new alarming.

Things like <click>

## Deviation from Status Quo

**Individual Analog Outputs for each actuator on the economizer dampers!**

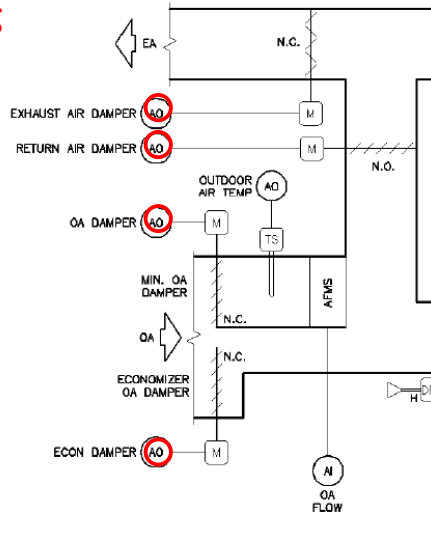

134

An example of this is

Learning a new mixing box control strategy.

Each damper of an economizer is now independently controlled to minimize mixing box pressure!

Image Source: GPC36 PPR1 05-16-2016



# Conventional Mixing Box Control

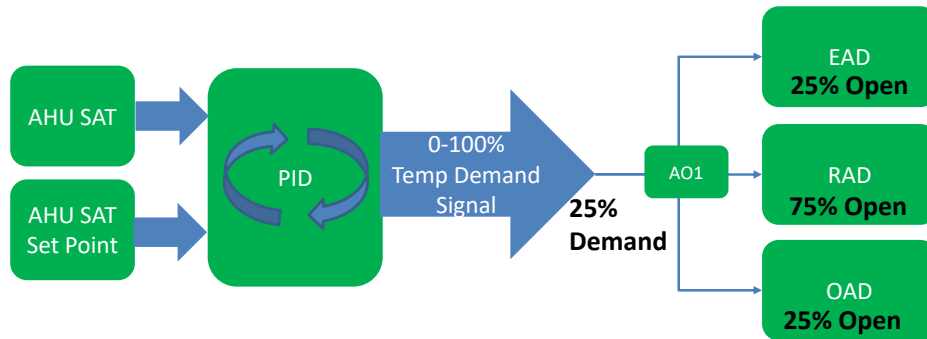

Multizone AHUs

CXassociates<sup>llc</sup>

Here is a typical Mixing Box control

Here a PID looks at the difference between AHU SAT and setpoint and calculates a demand signal.

This is entirely the demand based on deviation of temperature from setpoint.

All three dampers react in unison to this deviation in temperature.

It looks like this when graphed: <click>

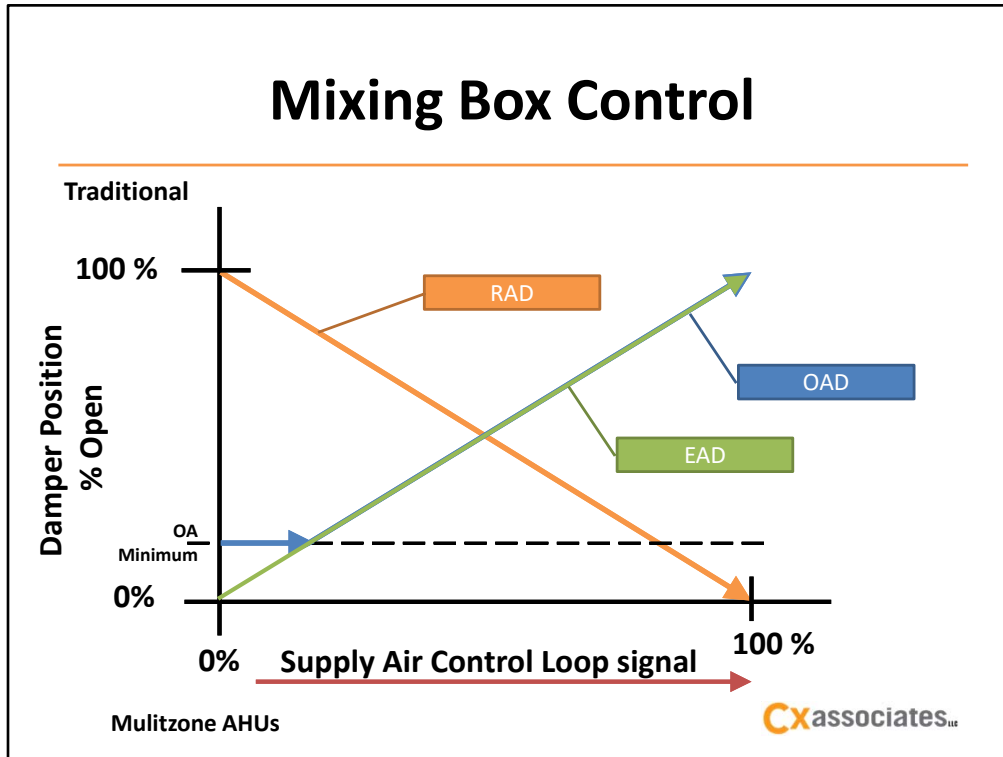

The dotted line is the minimum OA setting determined by the engineer to meet ASHRAE 62.1 requirements for ventilation.

Here you can see all three dampers react proportionally and simultaneously to that PID loop output.

Here is GL36's sequence:

# New Mixing Box Control

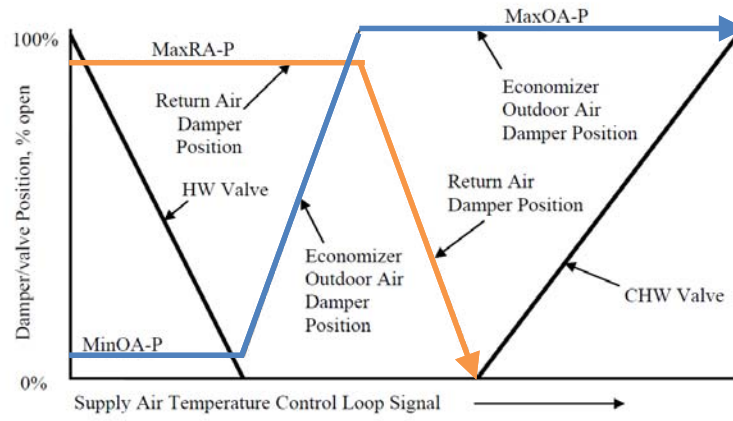

137

CXassociates<sup>llc</sup>

This mixing box control is very different from what you may have seen in the past.

Notice how they control based on supply air temperature demand

Staggered and sequenced.

Also notice that the variable names are different. That's because the GL gives recommendations on the maximum limits of these individual damper control strategies

The guideline also provides a secondary control sequence that will affect the dampers on OA intake control.

Image Source: GPC36 PPR1 05-16-2016

Rick

## Mixing Box Control with AFMS

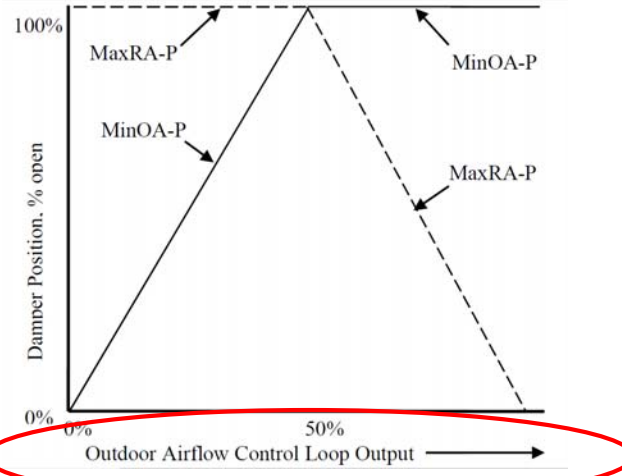

138 Multizone AHUs

CXassociates<sub>llc</sub>

Image directly from GL36

Notice here that this is in response to Outdoor Airflow control (from the AFMS that we talked about earlier).

So there are two controlling process variables acting on the same set of dampers here, and its important to review both sets

of sequence verbiage and tweak the variable as described in the guideline.

## RP-1455 Supporting Data

Economizer (not min OA) dampers are sequenced rather than complementary to save fan energy (reduced  $\Delta P$ )

At 50% open, both dampers are wide open rather than half closed

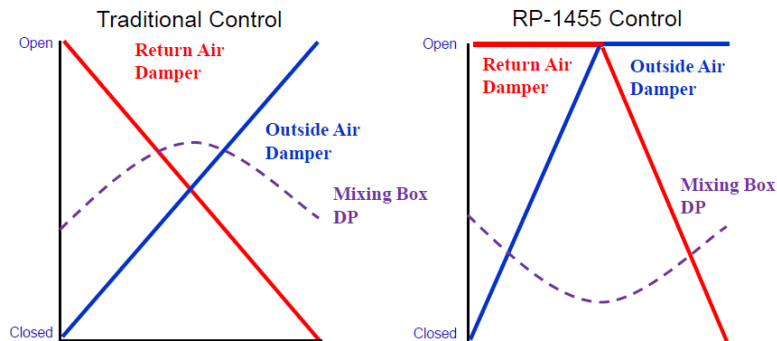

Source: 4/19/2016 Seminar at PEC

139 Multizone AHUs

CXassociates<sup>llc</sup>

They did this because they wanted to reduce the mixing box pressure thus saving fan energy on the supply fan

These charts are from the research project they conducted to inform this new sequence.

You'll notice that at 50% demand (they indicated open here), both dampers again are wide open.

Notice the difference in pressure as graphed by the dotted line.

Another key item to point out for Guideline 36 which can cause a learning curve is...

# ALL Adjustable

---

10. All setpoints, timers, deadbands, PID gains, etc., listed in sequences shall be adjustable by the user with appropriate access level whether indicated as adjustable in sequences or not. Software points shall be used for these variables. Fixed scalar numbers shall not be embedded in programs except for physical constants and conversion factors.

*All hardware points, not just inputs, should be capable of being overridden for purposes of testing and commissioning. For example, the commissioning agent should be able to command damper positions, valve positions, fan speeds, etc., directly through Building Automation System (BAS) overrides. The following requirement to equate hardware points to software points is necessary for systems that do not allow overriding real input points.*



140

CXassociates<sup>llc</sup>

**everything to be adjustable and overridable!**

**Image Source: GPC36 PPR1 05-16-2016**  
**<http://i.imgur.com/Waq9PDp.png>**

## All Adjusta-wha??!

---

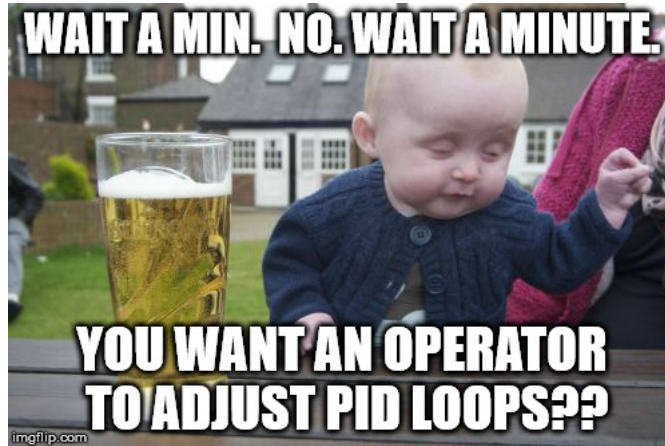

141

CXassociates<sup>llc</sup>

This concept of giving full control to operators of BAS systems can get a lot of people worked up.

Image Source: <https://imgflip.com/memegenerator/Drunk-Baby>

## If you're given the keys

---



142

CXassociates<sup>llc</sup>

I've been a proponent of this concept for almost two decades. My argument is, "if you're paid to operate a car and have the key, ,,,



**Well... yeah.**

---



143

**CX**associates<sup>llc</sup>

**you better be licensed to drive.”**

**Image Source: <https://wildninja.files.wordpress.com/2014/05/bad-drivers-7.jpg>**

## Trust in your people

---

*All hardware points, not just inputs, should be capable of being overridden for purposes of testing and commissioning. For example, the commissioning agent should be able to command damper positions, valve positions, fan speeds, etc., directly through Building Automation System (BAS) overrides.*

*The following requirement to equate hardware points to software points is necessary for systems that do not allow overriding real input points.*



144

CXassociates<sup>llc</sup>

**Testing, Tuning, commissioning, and troubleshooting benefit from this**

**If you hand this requirement out to a contractor, you can test and tune on your own.**

**Remember the contractor leaves, a building owner stays to deal with most of the system tuning whether they intend to or not.**

**So where does this leave us?**

# End of Upgrade - Rebalance of Whole building

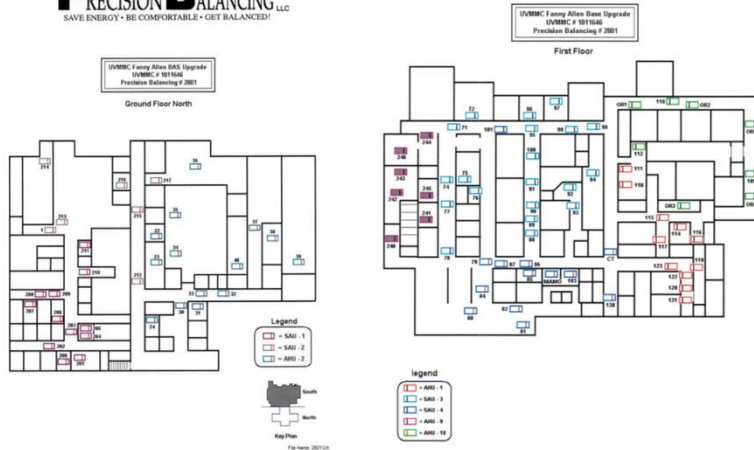

145

CXassociates LLC

The end of the project!

As system were brought online, they balanced the entire building.

This is a very important step. It confirms airflows are correct against the recalculated values and ensures your control system is reading accurately.

## Lessons Learned

---

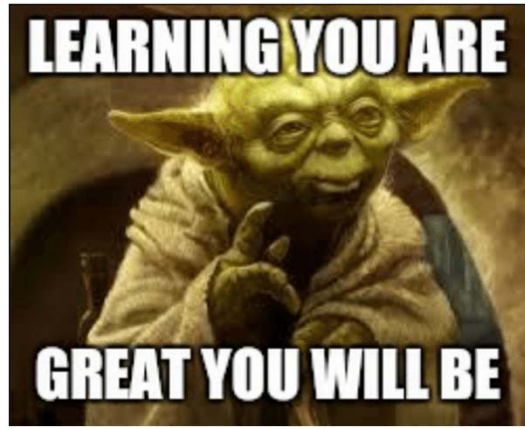

146

CXassociates<sup>llc</sup>

During commissioning and the first year of operation we learned a few things from this real world implementation.

First and most importantly

# Mixing box control is important in Vermont

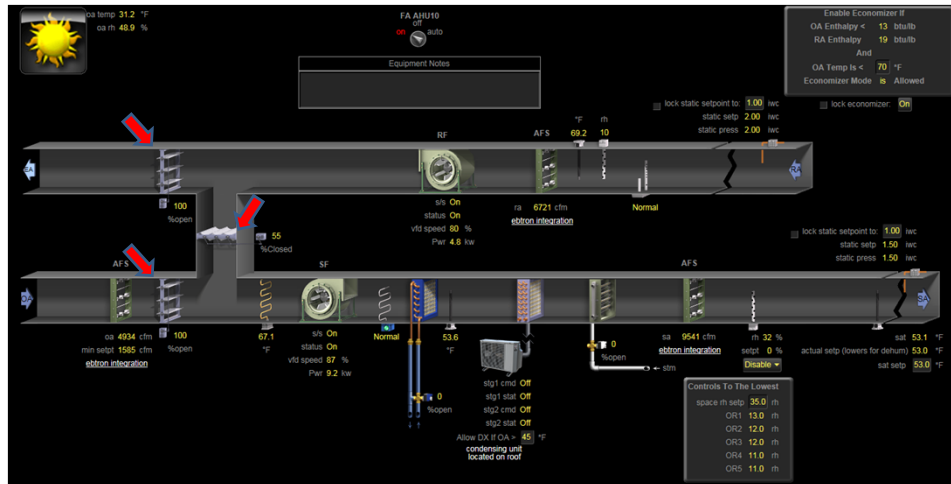

147

This slide illustrates A-36 mixed air box control.

The OA MOD opened up to 100%,

the EA MOD then opened up to 100%

and the RA MOD has opened to 45% open to maintain the supply air setpoint (1/10 away from setpoint).

You can see here that the mixing box is at 67.1°F showing that the ahU is favoring the return air over the outside air.

# Status Quo Just Works in some cases

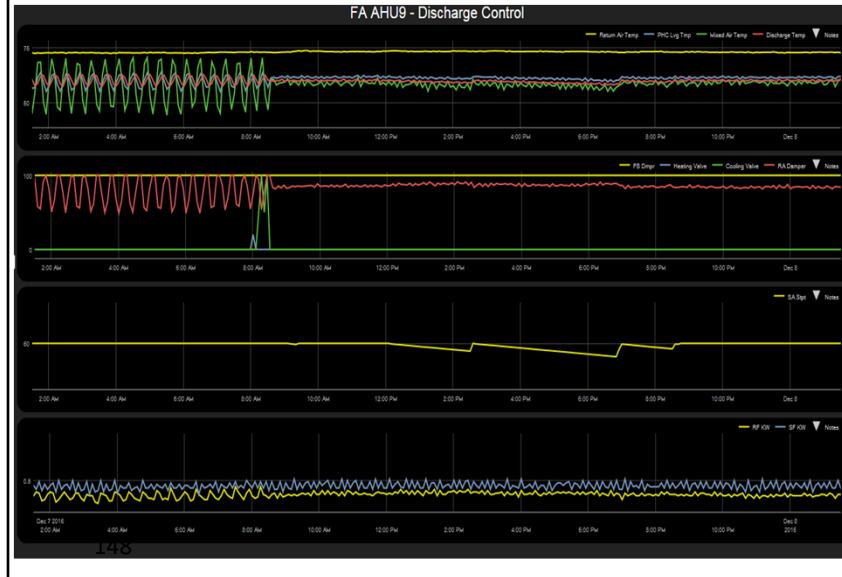

Notice:

Hyperactive damper actuators in Enhanced control mode.

Smooth damper actuation when using status quo damper control.

Reason? Turbulence, duct arrangement, etc.

Here is a graph of when they decided to flick the switch and go back to status quo control.

The dampers were clearly oscillating constantly to maintain appropriate supply air setpoint.

Switching to traditional mixed air box control resulted in steadier supply air temperature with less wear and tear on the dampers and actuators.

A further test will be conducted of enhanced mixed air box control during warmer outdoor air temperatures to see if AHU-9 can automatically switch between mixed air box operating modes at about 25 – 30 degrees.

## Fanny Allen 2015 - 2020

---



Since the BAS upgrade, Fanny has had

2016 - chiller replacement (300 Tons)  
(replacing a steam absorption chiller with a modern screw chiller)

A LED lighting upgrade

And a hot water system upgrade including Grundfos pumps.

I think they also got a roll up MRI machine.

# The Big Question?

---



150

CXassociates<sup>llc</sup>

**So did they save energy afterward?**



# Natural Gas

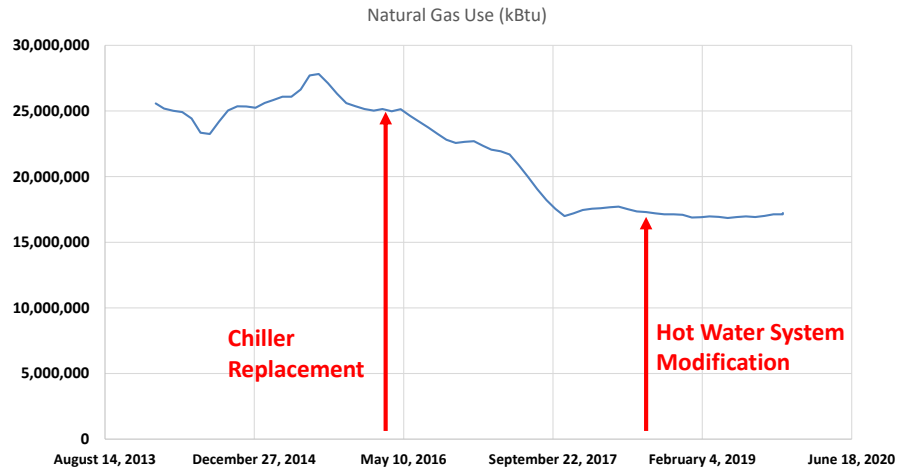

151

CXassociates LLC

**You can see a reduction in natural Gas consumption.**

**Some of this can be attributed to the loss of a steam fueled chiller, and hot water system upgrades.**

**Some of this can be attributed to the BAS upgrade as well.**

# Electricity Use

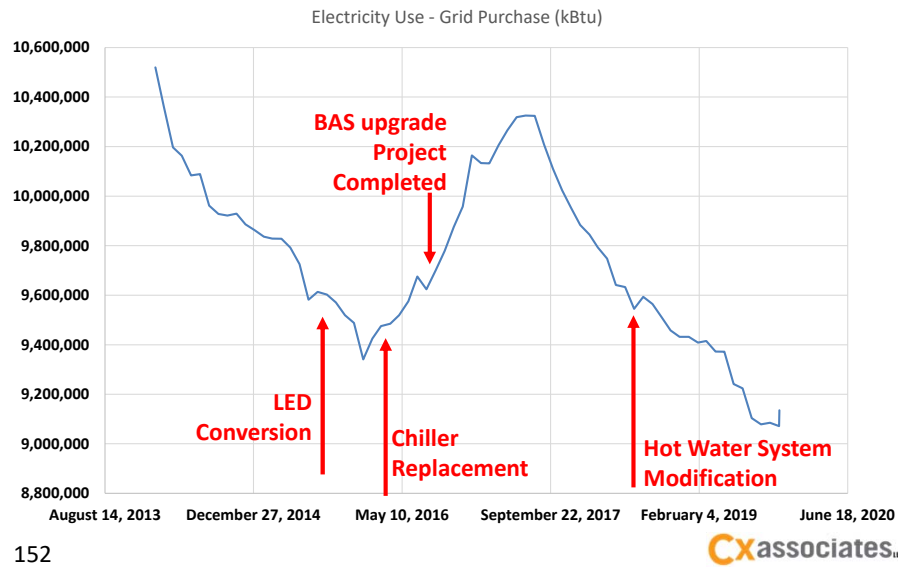

Again the same uncertainty is here due to lack of metered disaggregation, however I think all the projects in general are contributing.

# Awards

The screenshot shows the 'Energy to Care' awards website. At the top, there is a navigation bar with 'About' and 'Contact' links, a search bar, and a menu with 'Dashboard', 'Educational Tools', 'Treasure Hunts', 'Awards', and 'Supporters'. The 'ENERGY to care H' logo is on the left, with the tagline 'Greater efficiency supports patient care.' Below the navigation is the 'Award Winners' section, which states: 'Energy to Care award winners\* are recognized for reducing their energy consumption by 10 percent or more over their baseline energy consumption.'

**2019 RECIPIENTS**

**ENERGY CHAMPION**  
Aurora Sinai Medical Center

**2018 RECIPIENTS**

ENERGY TO CARE AWARD RECIPIENTS	2018 RECIPIENTS
SSM Health Dean Clinic East	The University of Vermont Medical Center - Fanny Allen Campus Colchester, VT
Trident Medical Arts HPR	North Charleston, SC
Prisma Health-Oconee Memorial Hospital	Seneca, SC
Aurora Health Center Plymouth	Plymouth, WI
Aurora Sinai Medical Center	Milwaukee, WI
Aurora Surgery Center - Manitowoc	Manitowoc, WI
Aurora Surgery Center - Southern Lakes	Burlington, WI
Parkview Noble Hospital	Kendallville, IN
Memorial Hermann Westside Hospital	Houston, TX
Methodist Hospital	Henderson, KY
The University of Vermont Medical Center - Fanny Allen Campus	Colchester, VT

**CXassociates** LLC

**Fanny won Energy to Care 2018 for 10% reduction**

**Again in 2019 for 10% reduction**

**Because it's a specialty hospital its not eligible for an energy star award, however its improvement energy star score was is drastic.**

## In conclusion

---



CXassociates<sup>llc</sup>

**This success came together as a result of:**

**careful and constant planning**

**Doing the homework, checking as-built documentation and developing it if it doesn't exist.**

**Providing time and resources to get into the details of guideline 36 and fit it to your applications.**

**Ensuring that third party commissioning occurs to check that implementation matches the design as closely as your MEP systems will allow.**

**Building a team and communication with them, including owner, implementers and designers.**

**Guideline 36 is now officially released. Its going to continue to grow.**

**This is a complicated approach that is mainly software driven and therefore requires a new standard of rigor to verify after implementation.**

**However given that it is software driven, the implementation costs can be lower than hardware swap out if you're willing to do the hard work.**

**Building automation systems have environmental impacts of 20 years or more so all of this is worth it!**

<http://f.tqn.com/y/chemistry/1/W/s/P/2/168351254.jpg>

# Questions?

---

**Thank You for attending!**



***Rick Stehmeyer - Senior Engineer***

